

AD A 076025

LEVEL II



Report OEHL TR-78-87

CEEDO-TR-78-38

LAND BASED ENVIRONMENTAL MONITORING AT JOHNSTON ISLAND
- DISPOSAL OF HERBICIDE ORANGE -

DDC FILE COPY

PREPARED BY:

T. J. Thomas, D. P. Brown, J. Harrington,
T. Stanford, L. Taft, and B. W. Vigon
BATTELLE Columbus Laboratories
505 King Avenue
Columbus, Ohio 43201

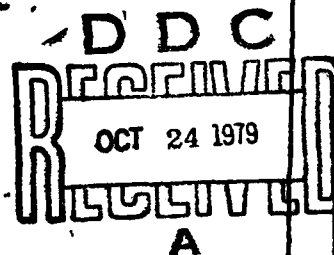

September 1978

Final Report for Period 11 May 1977 - 30 September 1978

Approved for public release; distribution unlimited

PREPARED FOR:

US AIR FORCE OCCUPATIONAL AND ENVIRONMENTAL
HEALTH LABORATORY
Brooks AFB, TX 78235

ARMAMENT DEVELOPMENT AND TEST CENTER
Detachment 1
Tyndall AFB, FL 32403

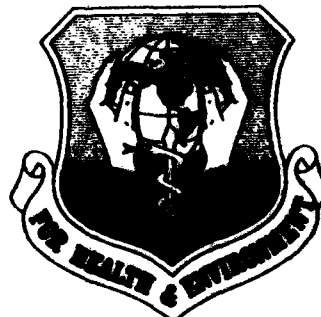

79 10 24 026

NOTICES

This report has been released to the National Technical Information Service, 5285 Port Royal Road, Springfield, Virginia 22161, for sale to the general public.

Qualified requestors may obtain copies of this report from Defense Documentation Center (DDC), Cameron Station, Alexandria, Virginia 22314.

This technical report has been reviewed and is approved for publication.

William E. Mabson
WILLIAM E. MABSON, Colonel, USAF, BSC
Commander

18) CEEDO; O.F.H.

UNCLASSIFIED

SECURITY CLASSIFICATION OF THIS PAGE (When Data Entered)

19) REPORT DOCUMENTATION PAGE		READ INSTRUCTIONS BEFORE COMPLETING FORM
1. REPORT NUMBER CEEDO TR-78-38, 78-78-87	2. GOV ACCESSION NO.	3. RECIPIENT'S CATALOG NUMBER Kajit
4. TITLE (and Subtitle) Land Based Environmental Monitoring at Johnston Island - Disposal of Herbicide Orange		5. TYPE OF REPORT & PERIOD COVERED Final May 77 - Sep 78
7. AUTHOR(s) T.J. Thomas, D.P. Brown, J. Harrington, T. Stanford & L. Taft, B.W. Vigon		6. PERFORMING ORG. REPORT NUMBER USAF OEHL TR-78-87
		8. CONTRACT OR GRANT NUMBER(s) P08635-76-D-0168
9. PERFORMING ORGANIZATION NAME AND ADDRESS Battelle Columbus Laboratories 505 King Avenue Columbus, Ohio 43201		10. PROGRAM ELEMENT, PROJECT, TASK AREA & WORK UNIT NUMBERS F0430P
11. CONTROLLING OFFICE NAME AND ADDRESS Arment Development and Test Center Detachment 1 Tyndall AFB, FL 32403		12. REPORT DATE September 1978
14. MONITORING AGENCY NAME & ADDRESS (if different from Controlling Office) U.S. Air Force Occupational and Environmental Health Laboratory Brooks AFB, TX 78235		13. NUMBER OF PAGES 323
		15. SECURITY CLASS. (of this report) UNCLASSIFIED
16. DISTRIBUTION STATEMENT (of this Report) Unlimited		15a. DECLASSIFICATION/DOWNGRADING SCHEDULE
17. DISTRIBUTION STATEMENT (of the abstract entered in Block 20, if different from Report)		
18. SUPPLEMENTARY NOTES The US Air Force technical manager for this project is Major James W. Tremblay (512) 536-3491.		
19. KEY WORDS (Continue on reverse side if necessary and identify by block number) Sampling, Analysis, Herbicide Orange, herbicide, water, sewage, air, biota.		
20. ABSTRACT (Continue on reverse side if necessary and identify by block number) As a part of the U.S. Air Force final Environmental Impact Statement of incineration of Herbicide Orange from Johnston Island, the Air Force stated that a monitoring program would be conducted to demonstrate that the land-based transfer operations were carried out in an environmentally safe manner. Battelle, Columbus Laboratories conducted these monitoring programs on Johnston Island. The monitoring of at-sea incineration operations were conducted by TRW and have been reported elsewhere.		

DD FORM 1473

EDITION OF 1 NOV 68 IS OBSOLETE

UNCLASSIFIED
SECURITY CLASSIFICATION OF THIS PAGE (When Data Entered)

407480

JK

UNCLASSIFIED

SECURITY CLASSIFICATION OF THIS PAGE(When Data Entered)

19.

Concentrations of 2,4-D and 2,4,5-T found in the ambient air and water samples were minimal. No TCDD was detected in any air or water samples. No changes that could be attributed to the operations were noted in indigenous plant or bird populations. Results of quality control sampling revealed that the required level of drum cleaning was achieved. Industrial Hygiene evaluations of the land-based operations revealed that only minor accidents or injuries occurred and exposure of workers to airborne 2,4-D and 2,4,5-T were well below permissible levels.)

No adverse consequences of the minimal release of Herbicide Orange into the Johnston Atoll environment were observed.

This report was submitted in fulfillment of Contract No. F08635-76-D-0168 by Battelle, Columbus Laboratories, under sponsorship of the U.S. Air Force. This report covers the period May 1977 to Sept. 1978.

UNCLASSIFIED

SECURITY CLASSIFICATION OF THIS PAGE(When Data Entered)

DISCLAIMER NOTICE

THIS DOCUMENT IS BEST QUALITY PRACTICABLE. THE COPY FURNISHED TO DTIC CONTAINED A SIGNIFICANT NUMBER OF PAGES WHICH DO NOT REPRODUCE LEGIBLY.

OR are
Blank pgs.
that have
Been Removed

**BEST
AVAILABLE COPY**

PREFACE

Headquarters US Air Force Logistics Command, Wright-Patterson AFB, OH, the office of primary responsibility for the project to dispose of Herbicide Orange, designated the US Air Force Occupational and Environmental Health Laboratory (USAF OEHL) as the agency responsible for land based environmental monitoring of this project. The Armament Development and Test Center, Tyndall AFB, FL negotiated and monitored this contract with Battelle Columbus Laboratories, Columbus, OH. Personnel of the USAF OEHL served as Technical Representatives of the Contracting Officer.

Accession For	
NTIS GRA&I	<input checked="" type="checkbox"/>
DDC TAB	<input type="checkbox"/>
Unannounced	<input type="checkbox"/>
Justification	<input type="checkbox"/>
By _____	
Distribution / _____	
Availability Codes	
Dist	Avail and/or special
A	

USAF CEEDO TR-78-38

FINAL REPORT

on

LAND BASED ENVIRONMENTAL MONITORING
AT JOHNSTON ATOLL - DISPOSAL
OF HERBICIDE ORANGE

to

U.S. AIR FORCE OCCUPATIONAL AND
ENVIRONMENTAL HEALTH LABORATORY

September, 1978

PART I

by

Thomas, T.J., Brown, D.P., Harrington, J.,
Stanford, T., Taft, L., and Vigon, B.W.
U.S. Air Force Project Officer: James W. Tremblay, Maj., USAF

BATTELLE
Columbus Laboratories
505 King Avenue
Columbus, Ohio 43201

DETAILED ENVIRONMENTAL ANALYSIS
OF PROJECT PACER HO

1. INTRODUCTION MATERIAL

This report is Part I of a three-part report on the environmental consequences of a project conducted on Johnston Island, labeled Project Pacer HO, designed to remove and incinerate the stocks of Orange Herbicide stored on Johnston Island since 1972. The three parts to the report are as follows:

- Part I Executive Summary
- Part II Detailed Environmental Analysis of Project Pacer HO
- Part III Supporting Data

In April, 1970, the Secretaries of Agriculture, HEW, and Interior jointly announced the suspension of certain uses of 2,4,5-Trichlorophenoxy acetic acid. As a result the Department of Defense suspended the use of Orange Herbicide since this herbicide consists of approximately 50 percent 2,4,5-T and 50 percent of 2,4-Dichlorophenoxy acetic acid. This suspension left the Air Force with 1.5 million gallons of Orange Herbicide (HO) in Vietnam and 0.8 million gallons in Gulfport, Mississippi. In September, 1971, the Department of Defense directed that the Orange Herbicide in Vietnam be returned to the United States and that the entire 2.3 million gallons be disposed of in an ecologically safe and efficient manner. The 1.5 million gallons were moved from Vietnam to Johnston Island for storage in April, 1972.

The cost of maintaining the storage areas, and the ever present danger from the stored HO stocks, let the Air Force to conduct a study to develop procedures for the ecologically safe, efficient, and, if possible, low-cost disposal of the approximately 2.3 million gallons of HO.

As part of their final EIS,^{*} the Air Force stated " a monitoring

* The final EIS for incineration of HO at sea. There were public hearings, and an EPA ocean dumping permit was issued.

program will be conducted to document herbicide exposures and environmental exposures should they occur. It is anticipated that this program will generate sufficient data to demonstrate that personnel and environmental safety of this operation". This report contains the results of the land-based monitoring program conducted during the HO disposal program on Johnston Island.

2. THE ORANGE HERBICIDE DISPOSAL PROGRAM

The Orange Herbicide stored on Johnston Island represented approximately 25,000 drums of 55-gallon capacity. These were stored in rows stacked three high in an area of about 3.5 acres on the northwest corner of the island, where the prevailing winds rapidly removed any atmospheric HO away from Johnston Island and the atoll and dispersed it in the open Pacific. There were no other locations containing HO.

Prior to the disposal operation, the sea environment caused drums to corrode and thus leak. The leakers were taken to a dedrumming facility where they were allowed to drain and were redrummed and restacked, while the old drums were crushed and stacked. The leaked HO caused a persistent and intense odor downwind of the drumyard.

For the HO disposal program, the dedrum facility was modified to allow transfer of the material from drums to bulk carriers for transport to an incinerator ship. The facility and operation basically consisted of a concrete pad and two fabricated metal racks upon which the full drums were placed in four groups of 12 each. Drums were transported from the drum yard to the racks in sets of four. The drums were then drained into a collection sump and spray rinsed twice with diesel fuel, exceeding the quality EPA requirements of 90 percent confidence of 85 percent residual removal.

After drainage, the drums were carried to the crusher, which consisted of a large weight suspended between two I-beams. The drums were compressed along the longitudinal axis.

Crushed drums were bundled and placed in storage on the seaward (downwind) side of the dedrum/crushing area. A large plastic sheet was used to protect the crushed drums from rain.

Herbicide was pumped from the collection sump into standard Air Force R-5* refueling trucks via a dry coupler bottom connection.

The refuelers transported the H0 to the wharf via a road which was set aside for this purpose. Non-project related vehicle traffic was forbidden along this section of roadway.

Once the refueler had reached the main wharf, the procedure was essentially reversed. The same type of dry couplings and spill prevention equipment were employed to pump out the tank and bulk transfer the material to the M/V Vulcanus, a ship designed for the incineration of hazardous materials. The area in which the pumps and hoses were located was diked with sand bags and plastic so that potential spillage could be contained.

The drum rinsing activities were subjected to constant monitoring to assure compliance with the EPA requirements. The second rinse from every 100th drum was sampled and analyzed for H0. A quality control chart was compiled from these analyses to assure that EPA requirements were being met on continuous basis.

A certified industrial hygienist was present during the complete operation. In addition to preventing deficiencies in personal hygiene and safety, he was responsible for the siting and operation of personnel samplers.

3. AIR

Surface trade winds were essentially constant throughout the study period with winds from the ENE to ESE at 10 to 20 mph on most days. Being remote from other terrestrial environments, the air at Johnston Atoll is clean, with none of the pollutants normally associated with urban areas.

Air sampling for 2,4-D and 2,4,5-T was accomplished utilizing Chromosorb 102 as an adsorption medium, a granular polymer well suited for collection of chlorinated hydrocarbons. This material was packed in micropipet tubes through which a sample volume of 150 liters was pulled at the rate of 0.50 liters/minute.

* On termination of the project, all equipment was decontaminated with a diesel fuel wash, which was then loaded on the ship.

Air sampling for the herbicide contaminant, tetrachlorodibenzo-para dioxin (TCDD), was accomplished utilizing benzene as the absorption medium. The apparatus consisted of a train of four impinger columns, the first two contained benzene, and the final two contained activated carbon to trap evaporating benzene.

In order to determine the impact of dedrumming and transfer operations on the air environment, four monitoring areas were chosen for sampling. These were the meteorology building (located 2 miles upwind for use as a background station), the wharf (300 feet downwind of the loading area), the dedrum facility (to determine occupational exposures), and a point 310 feet downwind of the dedrum facility. The chromosorb samples taken over the duration of dedrumming and loading operations yielded the following observations:

- Concentrations in samples taken at the upwind meteorology building ranged from levels below detection to trace amounts (less than 1 microgram per cubic meter).
- There was little difference between data recorded at the meteorology building and that at the wharf. The impact on air due to the loading procedure at the wharf was negligible.
- Total herbicide* concentrations detected 310 feet downwind of the dedrum site ranged from 3 to 23 micrograms per cubic meter.
- Concentrations inside the dedrum facility were only slightly higher, from 7 to 27 micrograms per cubic meter.

The OSHA 8-hour time weighted average allowable concentration for either/or 2,4-D and 2,4,5-T acids is 10 milligrams per cubic meter. All of the ambient measurements were negligible in comparison to the OSHA TWA.

The analytical results on air samples in the dedrumming facility show that personnel exposures were two to three orders of magnitude below the TLV of 10 mg/cubic meter for either 2,4-D or 2,4,5-T. No injuries or illness that occurred during dedrumming could be attributed to HO exposure.**

* Concentration reported as sum of 2,4-D and 2,4,5-T.

** Two cases occurred when HO was splashed in eyes. The eyes were immediately flushed without consequence.

Analysis of twenty benzene impinger samples showed all samples to contain less than the minimum detectable limit (MDL) of TCDD. MDL's ranged from 6.6 to 20.3 nanograms per cubic meter.

The impact of the disposal operation on the atmospheric environment was thus found to be insignificant.

4. WATER

The existing water environment of Johnston Island consists of several components of the hydrologic cycle. The saltwater cycle is comprised of the lagoon circulation and the groundwater underlying the island while the freshwater cycle includes the rainfall and the drinking water and sanitary system. Johnston Island's water system uses both fresh and saltwater.

The saltwater around Johnston Island and the freshwater system have been monitored for the presence of 2,4-D and 2,4,5-T since 1973. The maximum concentrations observed in the offshore area near the herbicide storage were on the order of 3 ug (micrograms) 2,4-D/liter and 0.6 ug 2,4,5-T/liter and those near the saltwater intake were 2.3 and 0.7 ug/l, respectively. The other two offshore sites exhibited maximum concentrations below 0.5 ug/l. Sample taken in the distillation plant never showed measurable concentrations, yet one sample from the storage reservoir showed 1.6 ug/l of 2,4,5-T. By comparison, most stringent standard appears to be the National Interim Primary Drinking Water Standard at 0.1 mg 2,4-D/l.

The sampling program for the water environment during the operation consisted of four offshore sites and two onshore sites. Samples were taken of the water near the main wharf at two points just off of the bow of the ship at 10-11 meters of depth. The saltwater intake for the desalination plant was sampled daily at about the same times as for the wharf samples and at a depth of five to six meters (about one meter from the bottom). The third offshore location sampled on a regular basis was the sewage outfall on the south side of the island. The fourth offshore site, sampled four times, was the shallow offshore area near the drum storage yard.

The location of one of the onshore samplers was in the fresh-water system equilization tanks immediately downstream from the desalination plant and prior to chlorination. The other onshore sampler monitored sewage in a sump near a lift station.

The water in the vicinity of the intake for the desalination plant was monitored on a daily basis. The level of herbicide ranged from below detection limits (0.1ppb) to 3.43 ppb. Over 50 percent of the samples analyzed had concentrations below 0.2 ppb, a factor for 500 less than the drinking water standard.

Potable water samples taken before the operation showed trace concentrations of 2,4-D in one sample. During the operation, herbicide concentrations* were found at trace levels (0.1 - 0.2 ppb) in 20 percent of the samples, again a factor of 500 below the drinking water standard.

Water samples were taken on alternate days in proximity to the sewage outfall, which is approximately 550 feet offshore. Only trace level of either 2,4-D or 2,4,5-T (0.1 - 0.2 ppb) were detected in the samples analyzed.

The sewage samples, contaminated from the washing of work clothes showed concentrations of herbicide** of from 20.7 ppb to 137.8 ppb. An estimated total of 0.94 pounds of herbicide was released into the sewage system, a markedly small figure in comparison to the amount handled.

Water samples were taken offshore and downwind of the dedrum facility four time during the operation. One sample contained trace levels of 2,4,5-T while all other samples analyzed had no detectable levels.

Water samples were taken on a daily basis in the vicinity of the wharf, which included special grab samples during the two deballasting periods from the M/V Vulcanus. The water in the immediate vicinity (10 feet) of the deballast discharge contained levels of herbicide that ranged from below detection to 8,117.7 ppb. The concentrations of these chemicals in the composited water samples at the wharf in the days following the deballasting illustrated an effective dilution process. The concentrations of herbicide dropped from 8116.7 to 1.90 to .75 ppb in the 2 days following the second deballast period. Including the deballasting periods, the concentrations of both 2,4-D and 2,4,5-T stayed below 0.2 ppb (trace) in over 50 percent of the samples taken.

* Concentration is reported as sum of 2,4-D and 2,4,5-T.

** Concentration is reported as sum of 2,4-D and 2,4,5-T.

The 11 water and sewer samples analyzed to date for TCDD show no measurable concentrations (MDL's ranged from 3.6 to 8.0 nanograms per liter).

With the exception of the deballast operation, the effect of the disposal operation on the aquatic environment was found to be insignificant. The deballast operation produced no signs of biotic impact, and aquatic concentrations decreased rapidly to nearly undetectable levels after deballasting.

5. BIOTA

The terrestrial environment of Johnston Atoll has been extensively studied. Although large numbers of aquatic, terrestrial, and avian species have been identified at Johnston Atoll, there is a paucity of native species, the atoll being a link in a migratory chain.

The large number of birds present on the atoll were nearly exclusively found on the three islands, unaffected by the presence of the disposal operation on Johnston Atoll. No signs of aquatic distress or change were noted in any aquatic community during disposal operations.

Young, potted tomato plants, *Lycopersicon esculentum*, 25-38 cm in height were used as biomonitoring organism to detect the presence of Orange Herbicide in the air. Tomato plants were used because of their sensitivity to HO damage in the parts per trillion range. The injury symptom typical of HO damage, known as epinastic growth, is described as a curling and/or twisting of the apical portion of the plant. Fourteen air biomonitoring sites or stations were selected on Johnston Island.

Three days of preoperational observations indicated that concentrations of Orange Herbicide sufficient to cause injury to the tomato plants only at two of the 14 stations. These two stations were approximately 500 feet from the deballasting site and directly downwind. During the operation, these two stations experienced the most frequent and most severe injury. Occasional damage was experienced at two peripherally downwind stations.

However, during the monitoring program, no significant physical or morphological changes were noted in any indigenous plant species on Johnston Island attributable to Orange Herbicide.

6. QUALITY CONTROL OF DRUM RINSING

Statistical sampling was made of drum rinse samples to assure the residual in the drums was less than that which would be left by the EPA triple rinse procedure. The drum rinse procedure was modified several times to improve removal; the drums on the average exceeded the required triple rinse efficiency.

7. SITE RECLAMATION

The U.S.A.F. has developed a continuing soil sampling program on Johnston Island, in the area of the drum storage yards. The purpose of the program is to monitor the degradation of HO in the old seepage areas from drum storage, so as to assure that the residual poses no environmental threat.

FINAL REPORT

on

LAND BASED ENVIRONMENTAL MONITORING
AT JOHNSTON ATOLL - DISPOSAL
OF HERBICIDE ORANGE

to

U.S. AIR FORCE OCCUPATIONAL AND
ENVIRONMENTAL HEALTH LABORATORY

September, 1978

PART II

by

Thomas, T.J., Brown, D.P., Harrington, J.,
Stanford, T., Taft, L., and Vigon, B.W.
U.S. Air Force Project Officer: James W. Tremblay, Maj., USAF

BATTELLE
Columbus Laboratories
505 King Avenue
Columbus, Ohio 43201

TABLE OF CONTENTS

	<u>Page</u>
1. INTRODUCTION	1
1.1 Background.	1
1.2 Need for Field Operations	2
1.3 Application of NEPA	2
2. EXISTING ENVIRONMENTAL FEATURES OF JOHNSTON ISLAND	3
2.1 Physical.	3
2.1.1 Land	3
2.1.1.1 Location.	3
2.1.1.2 Topography.	4
2.1.1.3 Geology	5
2.1.1.4 Soils	7
2.1.2 Air.	7
2.1.2.1 Meteorology During the Interval	7
a. Wind Speed and Direction.	8
b. Temperature	8
c. Precipitation	15
d. Dew Point	15
2.1.2.2 Air Quality	15
a. OSHA Standards.	16
b. Existing Pollution Source	16
c. Observed Ambient Air Pollution.	18
2.1.3 Water Environment.	18
2.1.3.1 Hydrology of Johnston Island.	19
2.1.3.2 Oceanography-Currents and Tides	20
2.1.3.3 Water Quality Criteria/Standards.	25
2.1.3.4 Existing Water Quality	39
2.1.4 Groundwater Quality.	42
2.2 Biological Environmental Features of Johnston Atoll	43
2.2.1 Terrestrial Environment.	43
2.2.1.1 Plants.	43
2.2.1.2 Invertebrates	45
2.2.1.3 Vertebrates	45
a. Fish.	45
b. Reptiles.	45
c. Birds	45
d. Mammals	53
2.2.2 Marine Environment	53
2.2.2.1 Plants.	53
2.2.2.2 Invertebrates	54
2.2.2.3 Vertebrates	54
a. Fish.	54
b. Mammals	55

TABLE OF CONTENTS (Continued)

	<u>Page</u>
2.3 Human Environment	55
2.3.1 Economic and Social.	55
3. DESCRIPTION OF ORANGE HERBICIDE DISPOSAL PROGRAM	56
3.1 Purpose	56
3.2 Operational Procedures.	56
3.2.1 Physical Manipulations	56
3.2.1.1 Drum Handling-Dedrumming.	56
3.2.1.2 Drum Crushing	65
3.2.1.3 Transport of HO to Disposal Ship.	65
3.2.1.4 Transfer to Disposal Ship	65
3.2.1.5 Cleanup	66
3.2.2 Descriptions of Project Activities	66
3.2.3 Physical Monitoring Sampling Protocol.	70
3.2.3.1 Chemical Sampling	70
a. Air	70
(1) Equipment and Procedures	70
(2) Air Sampling Sites	72
(3) Air Sampling Intervals	77
b. Water	79
3.2.4 Biological Monitoring Protocol	86
3.2.4.1 Bioassay Methodologies.	86
3.2.4.2 Birds	88
3.2.4.3 Vegetation.	89
3.2.5 Analytical Procedures.	89
3.2.5.1 Pre-Departure Tasks	89
3.2.5.2 Pacer HO Analytical Laboratory	91
3.2.5.3 Pacer HO Laboratory Management and Operation	93
3.2.6 Spill Prevention and Countermeasure Plan	105
3.2.7 Safety Plan.	106
4. ENVIRONMENTAL IMPACTS OF LAND-BASED OPERATIONS	108
4.1 HO Impacts on Natural Environment of Johnston Island	108
4.1.1 Land	108
4.1.2 Air.	108
4.1.2.1 Weather Station (CM).	108
4.1.2.2 Wharf	110
4.1.2.3 Downwind Station.	111
4.1.2.4 Dedrum Facility	115
4.1.2.5 Tomato Plant Bioassay	115
4.1.2.6 TCDD.	118
4.1.3 Water.	119
4.1.3.1 Dedrum Area Offshore (Site WD).	119
4.1.3.2 Wharf (Site WF)	125
4.1.3.3 Saltwater Intake (Site WS).	127
4.1.3.4 Potable Water (Site P1 [Composite] or P2 [Grab])	128
4.1.3.5 Sewage System (Site SE1 [Composite] or SE2 [Grab]).	129
4.1.3.6 Wastewater Outfall (Site WO).	131
4.1.3.7 TCDD	134

TABLE OF CONTENTS (Continued)

	<u>Page</u>
4.1.4 Biota	134
4.1.4.1 Vegetation	134
4.1.4.2 Birds	137
4.2 Human Environment	138
4.2.1 Industrial Hygiene	138
4.2.1.1 Air Monitoring	141
4.2.1.2 Accidents or Injuries	143
4.2.1.3 Miscellaneous	144
4.3 Non-HO Impacts	145
4.3.1 Temperature and Dissolved Oxygen	145
4.3.2 Operational Impacts	145
4.3.3 Land-Based Incineration of Wood Dunnage	148
4.3.4 Social and Economic Impact	150
 5. RELATIONSHIP BETWEEN LOCAL SHORT-TERM USES OF JOHNSTON ISLAND TO LONG-TERM IMPACTS	 151
5.1 Air	151
5.2 Water	151
5.3 Land	152
5.4 Biota	152
5.5 Summary	152
 6. MEASURES TO MITIGATE ENVIRONMENTAL IMPACTS	 154
6.1 Drum Yard	154
6.2 Dedrumming Facility	1-4
6.3 Change Building	154
6.4 HO Transfer	154
6.5 Cleanup	155
6.6 Site Reclamation	155
 7. UNAVOIDABLE ADVERSE ENVIRONMENTAL EFFECTS	 156
7.1 Air	156
7.2 Water	156
7.3 Land	156
 8. SUMMARY AND CONCLUSIONS	 157
8.1 General Summary	157
8.2 Weather Observations	157
8.3 Ambient Air Observations	157
8.4 Water Quality Observations	158
8.4.1 Saltwater Intake	158
8.4.2 Potable Water	158
8.4.3 Sewage Outfall	159
8.4.4 Raw Sewage	159
8.4.5 Dedrum	159
8.4.6 Wharf	159

TABLE OF CONTENTS (Continued)

	<u>Page</u>
8.5 Biological Observations	160
8.5.1 Tomato Plant Bioassay.	160
8.5.2 Vegetation Survey.	160
8.5.3 Bird Survey.	161
8.6 Industrial Hygiene Observations	161
LITERATURE CITED	162

LIST OF TABLES

	<u>Page</u>
1. Acute Toxicity Data for 2,4-D, 2,4,5-T and Derivative Acids, Salts, Esters, Amines, and Ethers	29
2. Sub-Lethal Effects of 2,4-D Derivatives Upon Aquatic Animals	30
3. Water Quality Criteria/Standards--Drinking Water	36
4. Operation Pacer HO Data Summary-Water Pre-Operational	41
5. Response Factors and Detection Limits for Methyl and Butyl Esters of 2,4-D and 2,4,5-T	95
6. Summary of All Concentrations at Ambient Air Monitoring Sites	109
7. Concentration Averages at Downwind Station	114
8. Concentration Averages at Dedrum Facility	115
9. Summary of Data Obtained from Tomato Plant Bioassay	117
10. Water Data Summary - Operational	120
11. Water Data Summary - Interim	121
12. Water Data Summary - Post Operational	122
13. Plant Species Observed on Johnston Atoll	136
14. Bird Species Observed on Johnston Atoll	139
15. Summary Table of Air Concentrations Personnel Samplers	142
16. Statistical Summary of Non-HO Water Data	146
17. Percent Dissolved Oxygen Saturation for Mean Temperature	147
18. U.S. Air Force Hi-Volume Sampler Results of HO Dunnage Burn, September 10, 1977	149

LIST OF FIGURES

	<u>Page</u>
1. Map of Johnston Atoll; Adapted from Amerson (1973).	6
2. Weather Observations at NOAA Station 1977	9
3. Features of Johnston Island	17
4. Inferred Lagoon Circulation (Westerly Flow), July-August, 1965, Kopensky and Wennekens, 1966.	23
5. Inferred Lagoon Circulation (Easterly Flow) July-August, 1965, Kopensky and Wennekens, 1966.	24
6. Microscale Current Directions at the Main Wharf, July, 1977 . . .	26
7. Water and Sediment Sites.	40
8. Breeding Cycles of Seabirds at Johnston Atoll	47
9. Monthly Cumulative Bird Populations, Johnston Atoll, 1963-1969. .	48
10. Monthly Mean Shorebird Populations for Johnston Atoll, 1963-1969.	50
11. Areas Used by Sooty Terns and Wedge-Tailed Shearwater on Sand Island, Johnston Atoll, 1965.	51
12. Nesting Areas of Ground Nesting Birds on the Original Portion of Sand Island, Johnston Atoll, 1963	52
13. Nesting Areas of Birds Which Normally Nest in Low Vegetation on the Original Portion of Sand Island, Johnston Atoll, 1963	52
14. Statistical Distribution of Second Drum Rinse Mass.	59
15. Drum Rinse - Quality Control Chart, Running Averages (All Data) .	61
16. Drum Rinse - Quality Control Chart, Running Averages.	63
17. Air Sampling Sites.	73
18. Air Monitoring Sites, Drummyard.	74
19. Sampling Sites at Dedrum Facility	75
20. Water and Sediment Sites.	80

LIST OF FIGURES
(Continued)

	<u>Page</u>
21. Saltwater Intake Sampling Points.	81
22. Location of Sewage Outfall Sampling Site.	82
23. Water Monitoring Site, Drumyard	83
24. Biota Monitoring Sites.	87
25. Check for Linearity	94
26. G C Chromatograms of (A) Chromosorb Sample CD 29Y707J and (B) Water Sample WS 30Y700J	99
27. Concentrations Measured at Downwind Station	112
28. Chronological Profile of Water Concentrations Contrasted with the Dedrumming Activities	123
29. Sewage System Discharges of 2,4-D and 2,4,5-T to the Offshore Area South of Johnston Island	130
30. The Distribution of Six Seabird Species	140

LIST OF PLATES

	<u>Page</u>
Plate 1. Aerial view of Johnston Island, showing incomplete reef	165
Plate 2. View of Empty Drumyard showing observation well	165
Plate 3. Two views of drum crusher. Left hand view shows standing water immediately after shower, and stain from residual diesel fuel expelled from drums	166
Plate 4. R-5 Refueler. Notice HO identification on tank	167
Plate 5. Diked area. Spills of several hundred gallons could be contained within the plastic lined area	167
Plate 6. Chromosorb tube, aluminum foil wrap, and storage tube. Pencil added for scale. Chromosorb material in left 1/3 of tube	168
Plate 7. Benzene impinger setup. Benzene flasks are wrapped in aluminum foil to prevent photo-decomposition of trapped species	169
Plate 8. Water sampling location off ship bow. Another site was located approximately 10 meters off the bow	170
Plate 9. Sediment sampling. Scuba gear required because of depth. Observation of divers led to understanding of subsurface currents	171
Plates 10, 11, & 12. Water and Chromosorb preparation laboratory	172
Plate 13. Safety equipment. Taken in dedrum facility, showing respirator, face shield, gloves and apron	173
Plate 14. Wharf air sample site. Wind direction, quartering bow, evident from flags	173
Plate 15. Air monitoring site at dedrum. Two views showing equipment on barrel. Lower view shows second site at far corner, on barrel.	174
Plate 16. Normal tomato plant	175
Plate 17. Tomato plant with level 2 injury (tip curling).	175
Plate 18. Tomato plant with level 3 injury (stem curling)	176
Plate 19. Tomato plant with level 4 injury (severe curling)	176

LIST OF PLATES (Continued)

	<u>Page</u>
Plate 20. Native flora downwind of drumyard. Tomato plant location in background	177
Plate 21. Epinastic growth in native flora (observed prior to Pacer HO Project)	177
Plate 22. Incinerator for wood dunnage	178
Plate 23. Typical operation of incinerator	178

DETAILED ENVIRONMENTAL ANALYSIS
OF PROJECT PACER HO

1. INTRODUCTION

This report is Part II of a three-part report on the environmental consequences of a project conducted on Johnston Island, labeled Project Pacer HO, designed to remove and incinerate the stocks of Herbicide Orange (HO) stored on Johnston Island since 1972. The three parts to the report are as follows:

- Part I Executive Summary
- Part II Detailed Environmental Analysis
- Part III Supporting Raw Data

1.1 Background

In April, 1970, the Secretaries of Agriculture, HEW, and Interior jointly announced the suspension of certain uses of 2,4,5-T*. As a result of this announcement, the Department of Defense suspended the use of Orange Herbicide since this herbicide consists of approximately 50 percent 2,4,5-T and 50 percent 2,4-D*. This suspension left the Air Force with 1.5 million gallons of Orange Herbicide in Vietnam and 0.8 million gallons in Gulfport, Mississippi. In September, 1971, the Department of Defense directed that the Orange Herbicide in Vietnam be returned to the United States and that the entire 2.3 million gallons be disposed in an ecologically safe and efficient manner. The 1.5 million gallons were moved from Vietnam to Johnston Island for storage in April, 1972.

The cost of maintaining the storage areas, and the ever present danger from the stored HO stocks, led the Air Force to conduct a study to develop mechanisms for the ecologically safe, efficient, and, if possible, low cost disposal of the approximately 2.3 million gallons of HO. After several proposals and draft Environmental Impact Statements, the ultimately accepted course of action was disposal by incineration aboard a specially

* 2,4,5-T is 2,4-T-trichlorophenoxyacetic acid, while 2,4-D is 2,4-dichlorophenoxyacetic acid. Both are commercial brand leaf herbicides.

designed incinerator vessel in an isolated location of the Pacific Ocean. The proposed incineration site met the criteria proposed in the Air Force document,⁽¹⁶⁾ "Final Environmental Impact Statement on the disposition of Orange Herbicide by incineration".

1.2 Need for Field Operations

As a part of their final EIS, the Air Force stated, "a monitoring program will be conducted to document herbicide exposures and environmental exposures should they occur. It is anticipated that this program will generate sufficient data to demonstrate the personnel and environmental safety of this operation". Air Force policy was that an independent contractor would perform the monitoring program. Thus, Battelle was ultimately selected by the Air Force to conduct the monitoring program for activities on Johnston Island. The ship board monitoring was conducted by TRW under contract with the U.S.A.F.

1.3 Application of NEPA

The Air Force complied fully with the tenets of the National Environmental Policy Act through their submission of a well considered and complete EIS. It was decided that the monitoring program results would be presented in a format commonly used to prepare EIS's.

2. EXISTING ENVIRONMENTAL FEATURES OF JOHNSTON ISLAND

The physical and biological features of Johnston Atoll and surrounding waters have been well studied and documented. The ecological baseline descriptions presented in this report are based primarily on accounts published by government agencies or by scientists under government contract. The two major sources of information are "Ecological Baseline Survey of Johnston Atoll, Central Pacific Ocean" by A. Binion Amerson, Jr.⁽¹⁾ and the "Natural History of Johnston Atoll, Central Pacific Ocean" by A. Binion Amerson, Jr., and Philip C. Shilton⁽²⁾. Both of these documents were prepared by the Smithsonian Institution, Washington, D.C. Tabular material and figures included in this section have been taken from the report prepared by Amerson and Shilton⁽²⁾. An aerial photo of Johnston Island is presented in Plate 1.

2.1 Physical

2.1.1 Land

2.1.1.1 Location

Johnston Atoll is located between the latitudes of 16° 40' 26" and 16° 47' 25" North and longitudes of 169° 24' 15" and 169° 33' 58" West. It is one of the most isolated atolls in the Pacific. The nearest land mass to Johnston Atoll is the French Frigate Shoal in the northwestern Hawaiian Islands, approximately 450 nautical miles (nm) to the north-northeast. Honolulu, Hawaii is 717 nm to the northeast, Kingman Reef of the Line Islands is about 850 nm to the southeast, Howland Island is 1,050 nm to the south-southwest, and the Marshall Islands lie almost 1,200 nm southwest of Johnston Atoll.

2.1.1.2 Topography

Johnston Atoll consists of four islands within a shallow lagoon partially enclosed by a semicircular reef to the north and west. Two of the islands are entirely man-made from dredged coral. These are Akau (North) Island at 16° 45' 52" N x 169° 31' 03" W and Hikina (East) Island at 16° 45' 26" N x 169° 29' 19" W, having land areas of 24 and 17 acres, respectively. The remaining two islands are highly modified natural islands, having been increased significantly from their original sizes. These are Johnston Island at 16° 45' N x 169° 32' W and Sand Island at 16° 45' N x 169° 30' W.

The smaller Sand Island (about 1,900 yards northeast of Johnston Island) was originally 10 acres in size with a maximum elevation of 15 feet above sea level. It has since been modified to include an area of fill of several acres about 500 yards west of the original island, and a causeway was constructed to join the two. The entire land mass (fill area, causeway, and original island) has been designated "Sand Island".

The only structures present on the original portion of Sand Island are the Loran-C transmitter building and the 625-foot transmitter tower. A few concrete foundations from buildings removed in the late 1950's and some gun emplacements still remain. Generally, the surface composition of the original island is a loose coral sand.

The largest island of the atoll, Johnston Island, was originally 46 acres with a maximum elevation of 48 feet. Manipulations made in 1939-1942, 1951-1952, and 1963-1964 enlarged the island to 570 acres using dredged coral from the lagoon, and leveled it to an average elevation of about 7 feet. The island is presently rectangular in shape with a 9,000 foot runway running in the southwest-northeast direction, almost along the island's main axis.

The surface of Johnston, Akau, and Hikina Islands, and the man-made portion of Sand Island are characterized by buildings, roads, and bunkers. Due to the packed, crushed coral surface composition of these

islands, vegetation is sparse. Only a few small lawns, scattered bushes and trees, and thinly scattered weed species exist. Figure 1 presents a schematic of the Islands and Reef of Johnston Atoll.

2.1.1.3 Geology

Johnston Atoll and its islands are situated atop a seamount of the mid-ocean Hawaiian Ridge. The surface lithology has been eradicated for the most part by construction activities on the island. The visible surface of Johnston Island is largely composed of dredged coral from the adjacent lagoon area. There is evidence of sea terraces that exist near the current mess facilities on the island more or less parallel with the main runway. Such terraces, step and grade towards the south tend to indicate that the basement seamount rim has undergone an uplift orogeny. Beachrock remnants are found on the original island's northwest and south central portions. The composition of this beachrock is primarily coral, fine sands and gravels that have been cemented together by calcium carbonates. Pumice rock was found erratically along a small section of the southeast shore of Johnston Island.

It has been cited in the literature⁽³⁾ that the outer reefs to the south of Johnston Island are submerged as a result of the tilting of the seamount basement structure towards a strike to the southeast. Due to the volcanic origin of the seamount that supports Johnston Atoll and to the evidence of unequal thrusting and settling Johnston Atoll is not considered to be a geologically stable land form.

The literature is deficient in describing the form and substance of the supporting seamount. There are apparently no exploratory deep wells on Johnston Island. There is evidence that the outer reef which breaks the surface of the sea only on the northern shore is undergoing differential settling or thrusting.

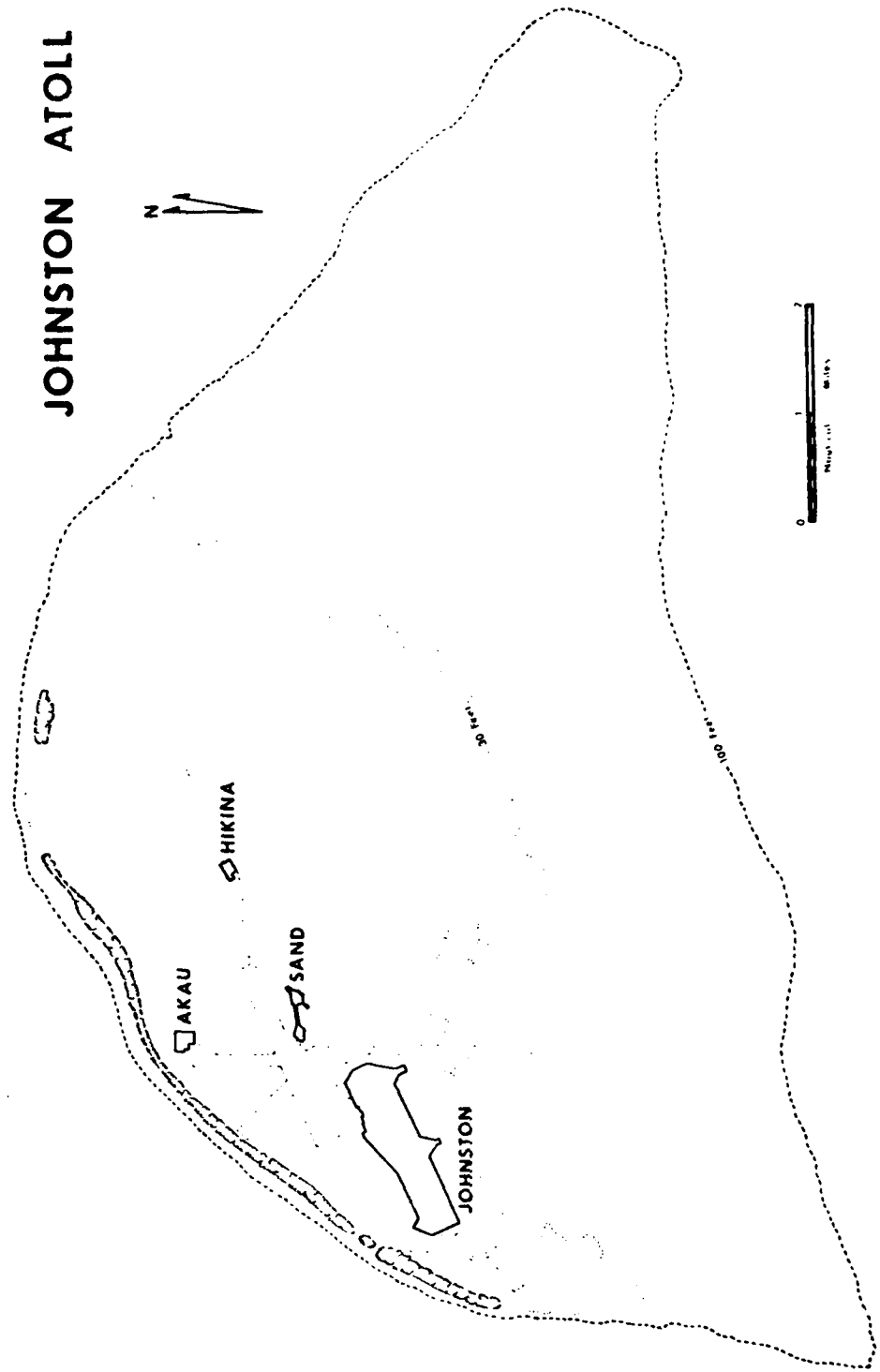

FIGURE 1. MAP OF JOHNSTON ATOLL; ADAPTED FROM AMERSON (1973)

Kroenke and Wallord⁽⁴⁾ surveyed Johnston Island gravity utilizing the Bouguer Anomaly effects. These studies suggest that the mass densities beneath Johnston Island are intermediate in value as compared with the Hawaiian Islands and Line Islands. These studies found no evidence of dense magmatic structure existing in the upper structure of Johnston Atoll.

The physical geology underneath the Orange Herbicide drum storage area contains alternating layers of coral and beach sands which have been artificially deposited and compacted. The permeability rates would be expected to be high in this unconsolidated dredge fill.

2.1.1.4 Soils

The soils occurring on Johnston, Akau, and Hikina Islands and the man-made portion of Sand Island consist of compacted coral fragments ranging in size from sand to cobble sized coral rock. These fragments were derived from dredging operations in the deepening and lengthening of ship channels and seaplane landing areas. The entire islands of Akau and Hikina and the man-made portions of Johnston and Sand Islands were constructed from this material.

The soil occurring on the original portion of Sand Island is deep, loose, coral sand. This surface is quite similar to that of Johnston and Sand Islands prior to their disturbance by military construction.

2.1.2 Air

2.1.2.1 Meteorology During the Interval

Meteorology data were recorded at the NOAA weather station located on the eastern end of the island. An additional anemometer with strip chart recorder was maintained near the drum storage area (for the period July 20 to August 27, 1977) which recorded additional wind data for the western end of the island.

The meteorological records for wind speed, direction, temperature, dewpoint, and rainfall are presented in Figure 2. Superimposed on these data, collected by the NOAA station are the wind speed and direction at the west end anemometer for several sample weeks. These data are discussed further below. In these discussions, the recorded values are compared to norms which were assembled from 30+ years of data and presented in Amerson.⁽¹⁾

a. Wind Speed and Direction

Surface trade winds were essentially constant throughout the period. Winds were from the east-northeast to the east-southeast at from 10 to 20 m.p.h. on most days. The exceptions occurred on August 8 and 9, 1977, and again over the interval August 14 to 16, 1977, when winds were at 0 to 10 m.p.h. from the northeast. Only one directional shift of significance occurred during the period. On August 10, winds were out of the south at about 10 m.p.h. Minimum variation from seasonal norms was experienced over the duration.

A comparison of the data taken at the two wind recording stations indicated only a negligible difference. Wind directions were very slightly more northerly at the drum storage station. Also, wind speeds were a few m.p.h. less at this station, attributable to the drag effect of the entire length of the island.

b. Temperature

As a result of air masses passing over the atoll having been conditioned by close contact with the ocean for thousands of miles, there is little daily variation in air temperature. Similarly, only very small seasonal differences exist (about 3° F), with August being the warmest month of the year.

Throughout the period observed, daily highs ranged from 83° F to 85° F. Lows were usually between 77° F and 80° F, with a daily mean of 81° F, which is normal for this time of year.

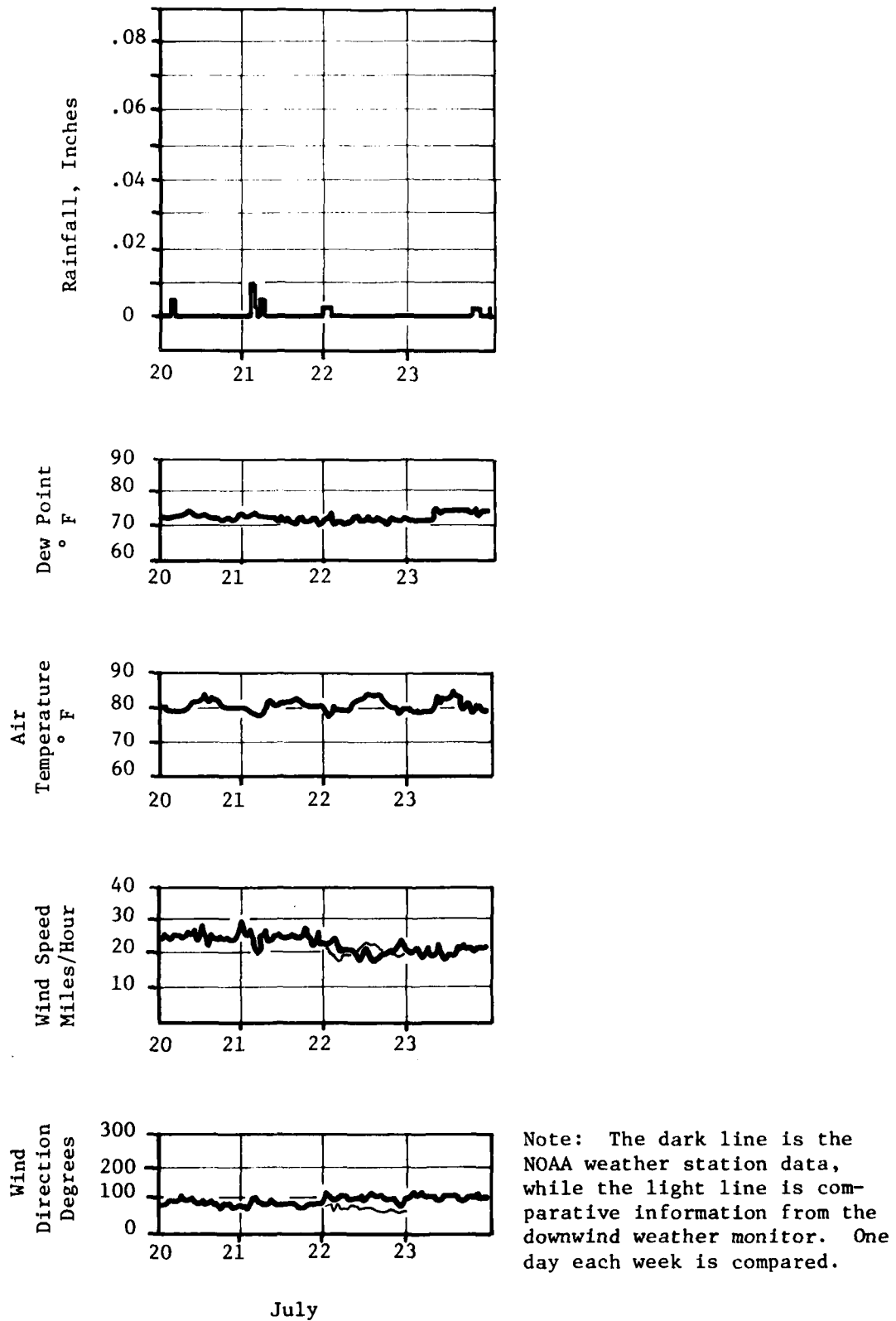

FIGURE 2. WEATHER OBSERVATIONS AT NOAA STATION, 1977

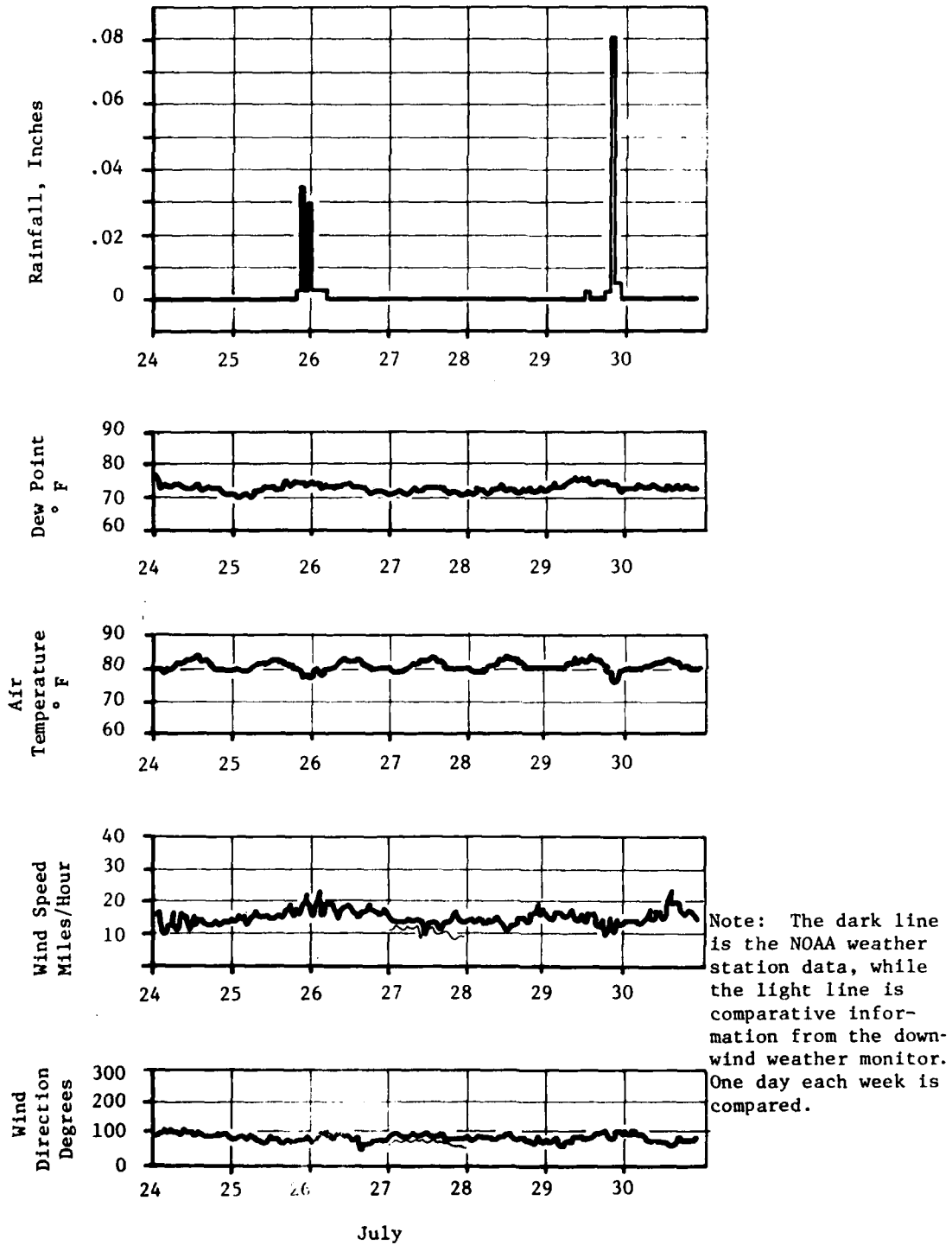
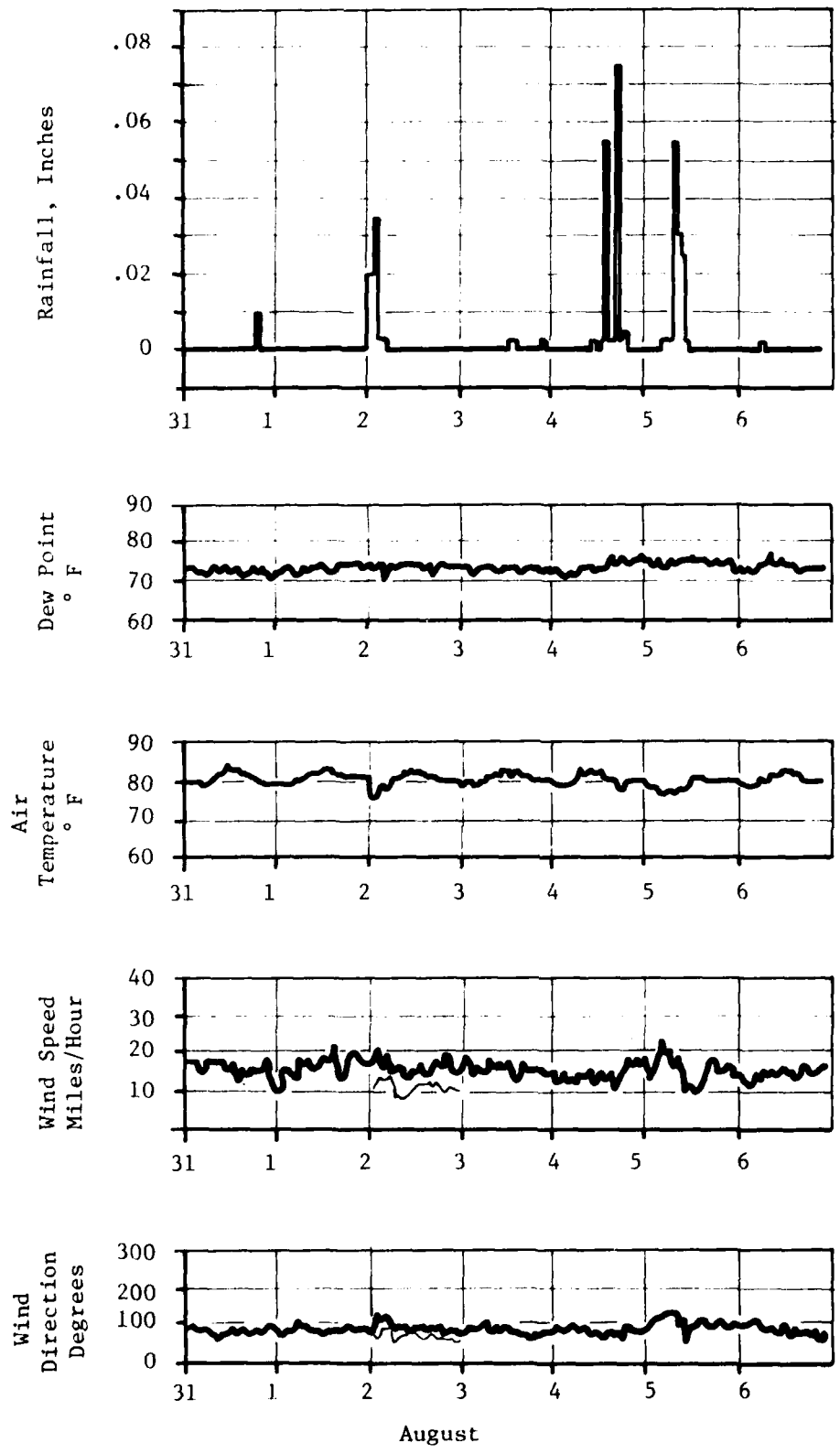
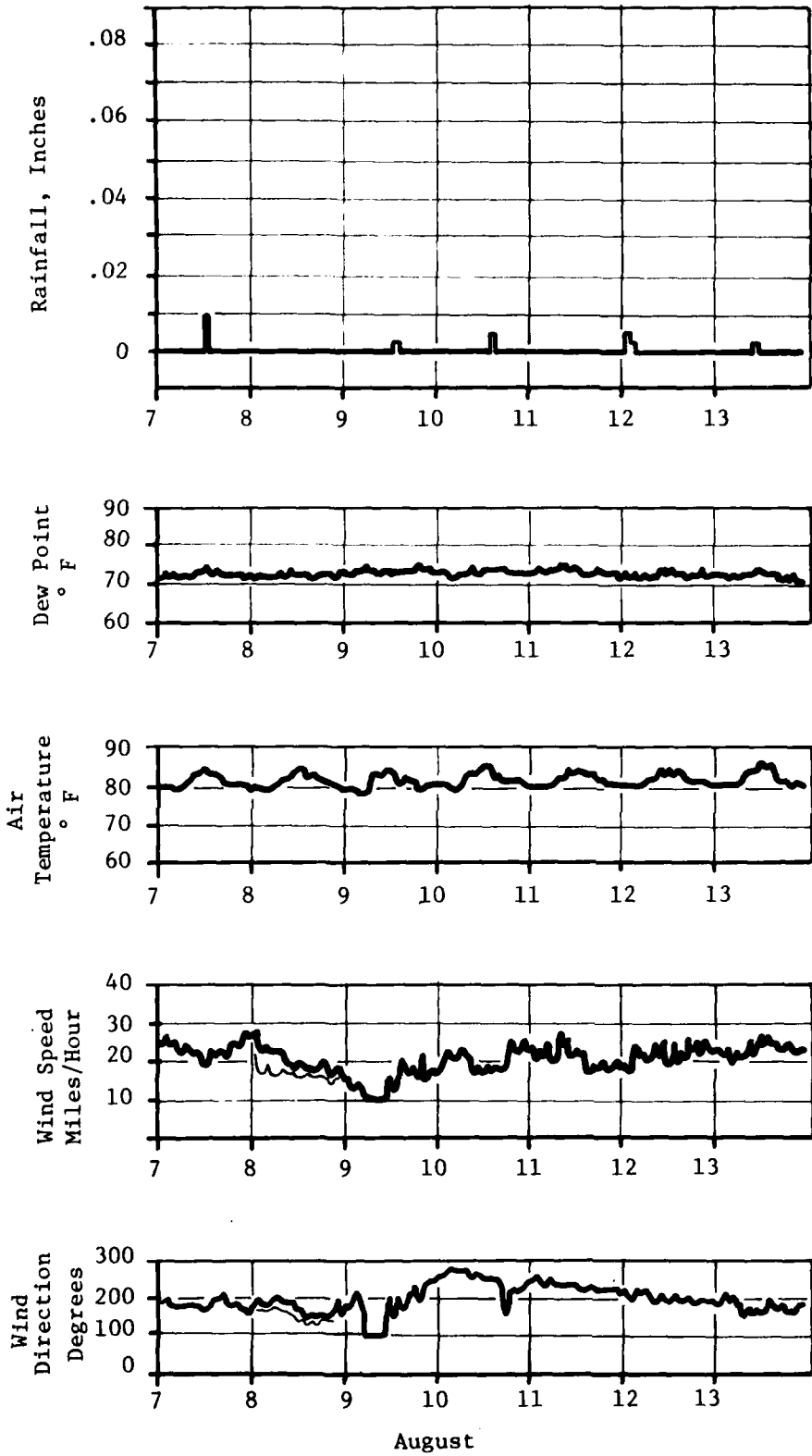

FIGURE 2 . (Continued)



Note: The dark line is the NOAA weather station data, while the light line is comparative information from the downwind weather monitor. One day each week is compared.

FIGURE 2. (Continued)



Note: The dark line is the NOAA weather station data, while the light line is comparative information from the down-wind weather monitor. One day each week is compared.

FIGURE 2. (Continued)

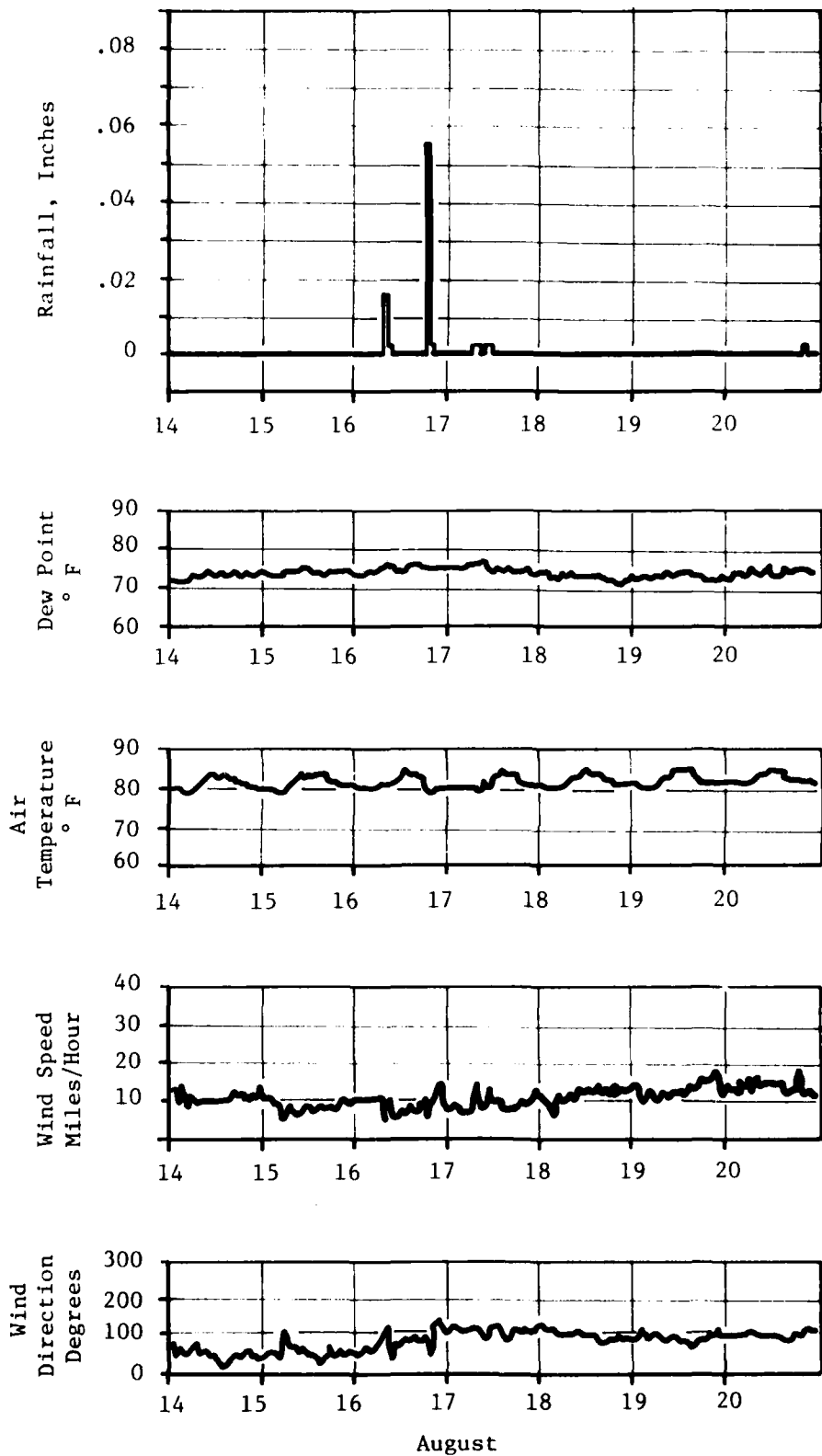

Note: The dark line is the NOAA weather station data, while the light line is comparative information from the down-wind weather monitor. One day each week is compared.

FIGURE 2. (Continued)

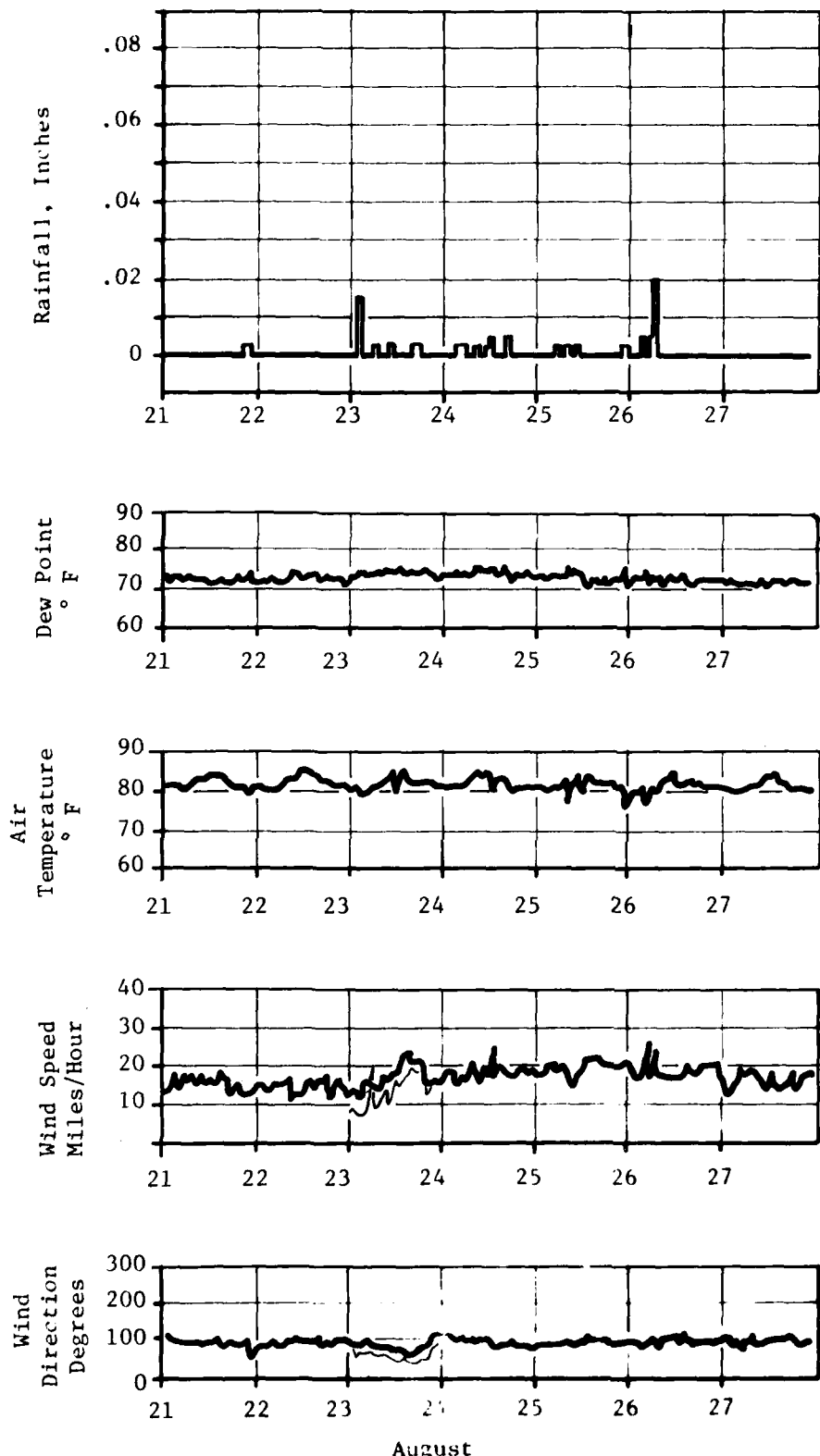

Note: The dark line is the NOAA weather station data, while the light line is comparative information from the down-wind weather monitor. One day each week is compared.

FIGURE 2. (Continued)

A very slight warming trend (1-2° F) was observed from the beginning of operations in late July through the end in late August. This was to be expected because the monthly mean for July is about a degree Fahrenheit less than that for August.

c. Precipitation

Rain is extremely variable on the island in both frequency and intensity. The accumulated measurable rainfall was 1.3 inches during the 39-day period. In addition to measurable quantities, trace amounts were observed over hourly intervals on 58 occasions. The heaviest rains (more than 0.10 inches/hr) occurred on July 29, August 4, August 5, and August 16. Rain was most frequent over the intervals August 3 through 5 and August 23 through 26. In comparison to the norm for the season, the period was a rather dry one, with rainfall at about 55 percent of the total expected. However, the rainfall was well within the observed extremes of 0.4 to 10 inches for the total period.

d. Dew Point

Dew point temperatures ranged from 70° F to 77° F throughout the period. Highest readings (75° F) were recorded during periods of rain. On no occasion, however, was the dew point ever reached.

2.1.2.2 Air Quality

Being remote from other terrestrial environments, the air at Johnston Atoll is clean, with none of the pollutants normally associated with urban areas. The only air contaminants expected at Johnston Island are those introduced at Johnston Island itself. Routine insecticide spraying was suspended during the HO operations on Johnston Island.

The following sections discuss the applicable air standards, existing sources of HO atmospheric, and observed atmospheric HO concentrations prior to the dedrumming operations.

a. OSHA Standards

Christiansen⁽⁵⁾ discusses the toxicity of 2,4-D and 2,4,5-T and its n-butyl esters. No inhalation toxicities are reported for any species.

The Occupational Safety and Health Administration has established 8-hour time weighted average concentration occupational standards for the acids of 2,4,-D and 2,4,5-T. For both chemicals the standard is 10 milligrams per cubic meter (10,000 $\mu\text{g}/\text{m}^3$).

The constituents of Orange Herbicide, however, are the n-butyl esters of the acids. There are no OSHA (or any) standards for exposure to the esters. However, the reported animal toxicities in Christiansen⁽⁵⁾ for the butyl esters are even lower than for the acids. It is reasonable to assume that 10 mg/m^3 is a realistic human TWA exposure limit for humans.

b. Existing Pollution Source

The herbicide was stored in a drum storage yard at the northwest corner of the island as illustrated in Figure 3. At this location, the prevailing winds rapidly removed any atmospheric HO away from Johnston Island and the atoll and dispersed it in the open Pacific. There were no other locations containing HO.

Prior to the disposal operation, the salty environment caused drums to corrode and thus leak. A team of men patrolled the drumyard looking for fresh HO sorbed on the ground, an indication of a leaking drum. While an exact measurement was not made, an estimate of from 20 to 70 would be found leaking each week.

The leakers were taken to the dedrumming facility where they were allowed to drain into a covered collection sump over a period of days. On a weekly basis, the collected drainage would be redrummed in new drums and restacked, while the old drums would be crushed and stacked.

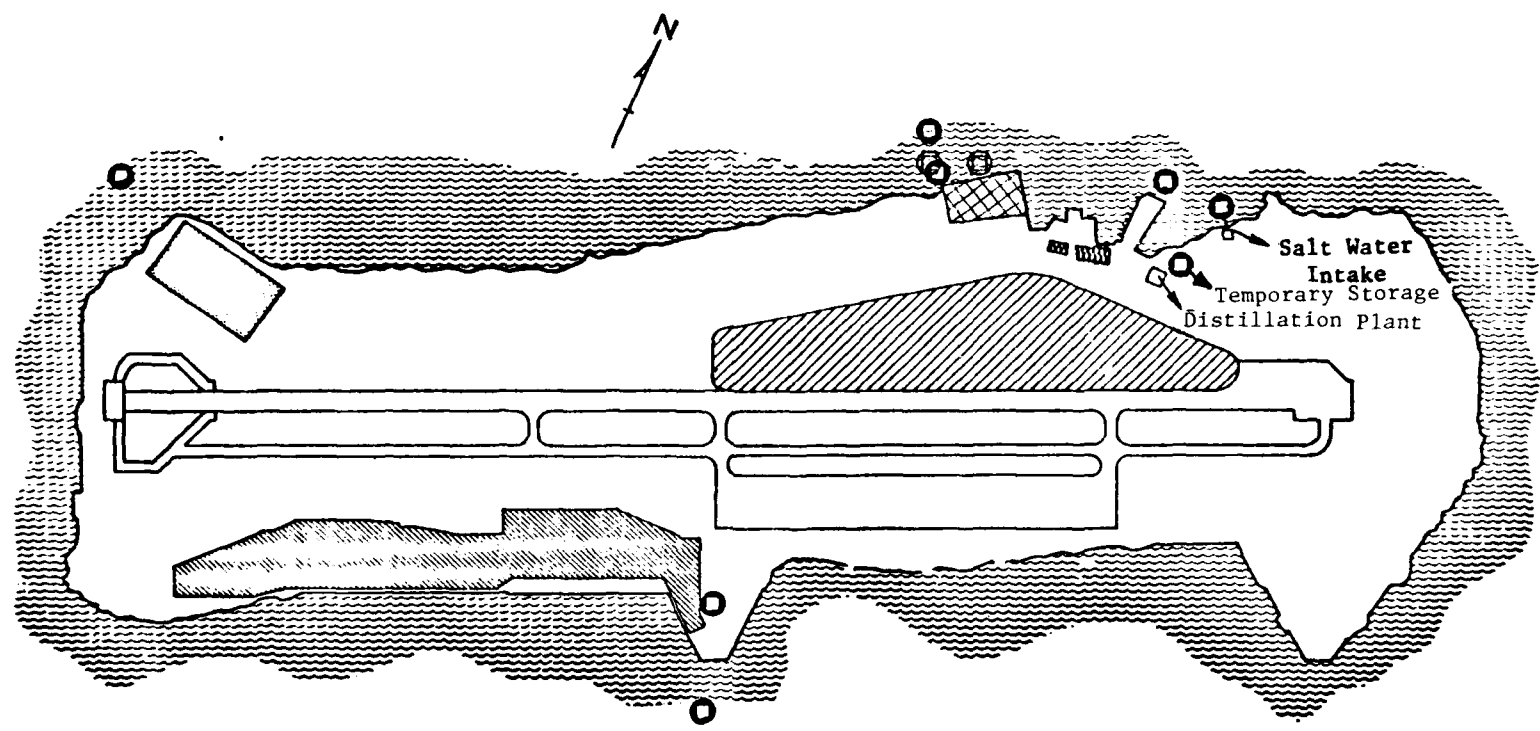

- Water Sampling Sites
- Sediment Sampling Sites
- Analytical Buildings (Bldgs 120/190)
- Red Hat Area
- ▨ Johnston Island Crew Facilities
- ▣ Wharf
- ▩ Dedrum Area

FIGURE 3. FEATURES OF JOHNSTON ISLAND

There is no measurement of the volume actually leaked. The incineration records show that the average drum contained 53.9 gallons, but it cannot be said that all drums were initially full.

c. Observed Ambient Air Pollution

While concentration measurements downwind of the site were not made prior to the HO operation, the values for 2,4-D and 2,4,5-T in the pre-operational period averaged 0.49 and 0.08 $\mu\text{g}/\text{m}^3$, respectively, at the downwind station. Furthermore, the odor of the trichlorophenols in the HO was intense across the entire downwind boundary of the drumyard.

The consistent, strong winds at Johnston Island are helpful in the removal and dispersion of HO from the atoll. It is expected that the atmospheric stability is typically Class B* during the day and Class D at night. With these stabilities, dispersion processes should reduce concentrations by a factor of 10 within 1.6 kilometers downwind (day) and 4.4 kilometers (night).

2.1.3 Water Environment

The existing water environment of Johnston Island consists of several components of the hydrologic cycle. Because of the small size of the island, cycling of material between the hydraulic components is expected to be rapid. The hydrologic components described below include the saltwater and freshwater portions of the cycle. The saltwater cycle is comprised of the lagoon circulation and the groundwater underlying the island while the freshwater cycle includes the rainfall and the drinking water and sanitary system.

* Turner's stability classes.

2.1.3.1 Hydrology of Johnston Island

Precipitation in excess of 0.01 inches occurs on the average of 162 days per year. The mean annual rainfall is 26.11 inches, however, variation from year-to-year is considerable. Monthly rainfall variations are small. During the period 1931-1972, July rainfall averaged about 1.6 inches while August rainfall was about 2.2 inches. In the Central Pacific tropical climate, evaporation is much greater than precipitation. This, together with the flat topography and permeability of the soils minimizes sheet runoff. Storm drainage is collected in a system of French drains, inlets, and open ditches which flow into the lagoon. Since most rains are very light, flow in these ditches is intermittent with evaporation being the predominant removal process. Transpiration from plant surfaces is a very minor part of the hydrologic cycle of the island because of sparse vegetation due to the large areas of paved or otherwise impervious surfaces and base coral.

There are no permanent freshwater bodies on Johnston Island. The lack of surface water is due to the coarse texture and extreme permeability characteristic of the surface coral sands (Thorp⁽⁶⁾). Other factors contributing to the lack of significant amounts of fresh groundwater are the small land area, narrowness of the island and the high permeability which allows rapid mixing between the lagoon water and the percolating rainwater.

Johnston Island's water system uses both fresh and salt water. Raw sea water is pumped from the lagoon through a traveling screen to the Salt Water Pump House. From there it is pumped to the Distillation Plant and also into the salt water distribution system where it is used for sanitary purposes, fire protection, air conditioning condenser units, and power plant waste heat dissipation. The Distillation Plant houses twelve distillation units and related equipment; the Freshwater Treatment Plant consists of a pump station, soda-ash treatment area, and a chlorination room and storage facilities for approximately 740,000 gallons (Figure 3). The freshwater system is designed to support a population of approximately

4,500. Its total rated capacity is 318,000 gallons per day (gpd), but, allowing for maintenance and miscellaneous downtime, about 240,000 gpd can be expected at peak production.

Johnston Island has insufficient relief to permit use of a gravity sewage collection system; therefore, a forced system employing pumps and lift stations is used. The force main is a series of 3" to 16" cast iron and asbestos cement pipes in parallel runs along the north and south shores with connecting laterals. Raw effluent is discharged on the ocean bottom at a depth of 25.6 feet through a 10 inch pressure outfall pipeline which extends approximately 550 feet out from the southwest peninsula of the Island.

2.1.3.2 Oceanography-Currents and Tides

Johnston Island is approximately in the center of the North Equatorial Current which extends to the north and to the south of the island for several hundred miles. The velocity of this current is relatively constant from east to west at about 1/2 knot (0.41-0.63 mph; 0.61-0.82 ft/sec; 0.17-0.25 meters/sec).

The underwater platform on which Johnston Island is located is similar to those associated with many Pacific atolls. Like most other low islands in the Pacific, the main outer reef has a typical cross section, which includes surge channels, an algal ridge, and a reef flat, with coral heads rising abruptly in the deeper waters to the south and east of the main reefs. The outer slope is quite steep, between 16 and 100 fathoms, usually less than one-half mile in linear distance, with an average slope of 19°. The platform on which Johnston Atoll rests stops fairly abruptly at about the 16 fathom line at most points around the circumference of the atoll as the bottom begins to slope steeply down. (7,8,9)

The shallow lagoon area and its bordering reefs together form roughly the northwestern quarter of the triangular-shaped platform on which the atoll rests. At the deeper eastern end of the platform the submerged contours suggest the outline of earlier peripheral reefs. The

main difference between Johnston Atoll and other Pacific islands is the lack of continuous reef around the atoll. The main outer reef extends around less than one-fourth of the circumference of the platform. In addition, there is an extensive zone of shallows to the south of the main reef which is also an unusual feature.

The tidal range at Johnston Island, in common with other mid-Pacific islands, is relatively small and the effects of the tides upon the atoll are correspondingly minor. The absolute tidal range during the year (the difference between the lowest and highest tides of the year) is only 3.4 feet. The lowest low is minus 0.5 foot in June, while the highest high is plus 2.9 feet in June and July. The mean spring high tides are plus 2.2 feet while the mean spring low tides are minus 0.2 foot. The mean neap tides are plus 1.6 feet, while the mean neap low tides are plus 0.4 foot.^(6,7,8) The time of the tidal crests and troughs is only slightly later than those of Honolulu, the nearest point for which a full tide table is available. High tides are 29 minutes later at Johnston Island than at Honolulu, while the low tides are 23 minutes later. The high-water interval from full tide to the change of tide is three hours and 15 minutes. Tide tables for July and August, 1977, are shown in Table III-14*. The maximum high tide during the assessment occurred from July 27 to 29 and measured plus 2.9 feet while the lowest tide was minus 0.1 feet on July 24, 28 and 31.

The ocean currents around Johnston Atoll exert a major influence on the localized circulation within the lagoon because of the "open" structure of the marginal reefs. In addition, the tides have a range within the lagoon only slightly less than in the deep water because of this feature.

Tidal currents within the lagoon show some variation with the season. During July and August, the normally strong westerly flow weakens somewhat. This allows a divergent flow field to be generated to the southwest of the atoll platform. This type of flow was characterized by

* This notation refers to Table 14 of Level III Report. The notation will be frequently used throughout this report.

a moderate offshore current with a general set toward the west. Local tides induce clockwise rotary to semi-rotary motions in the regional and local circulation patterns. During rising tides, the predominant flow is to the north in the east and west ship channels and to the northwest in the north channel (Figure 4). The normal current speeds are about 1/2 knot. During falling tide, however, the predominant flow was to the south in the east and west channels and to the southeast at about one knot in the north channel (Figure 5). (3,8,9)

These current movements are affected by the numerous patch reefs found in many places. The natural depths within the lagoon (except for the dredged portions) vary from a few inches to about 40 feet, because of the presence of coral heads and patch reefs. The greatest area lies between 15 and 25 feet underwater at mean sea level.

The lagoon inside the main atoll is about 14,000 yards long at its axis, which runs southwest from Small Island through the center of both Sand and Johnston Islands. At its widest point, just east of Sand Island, the lagoon extends about 3,500 yards from northwest to southeast. West of Johnston Island the lagoon narrows to a few hundred yards in width before coming almost to a point at the extreme southwestern corner of the atoll.

The total area of the lagoon within the reef is approximately 13 square statute miles. An exact measurement is difficult because of the need to measure the exact line of demarcation between the lagoon proper and the extensive coral flats which form the southeastern part of the atoll. (6,7) At the extreme northeastern corner of the lagoon, south of the opening between the main reef and North Island, there is an area of deeper water in which average depths of more than 40 feet have been reported, but the bottom still has many irregularities and numerous coral heads which almost broach the surface. Artificial dredging in the lagoon has left the seaplane landing area with a depth of eight feet cleared of obstructions, while the harbor and the entrance channel were originally dredged to 23 feet and have been swept to 14-1/2 feet. An approximate value for the volume of water enclosed by the reef is $1.5 \times 10^{11} \text{ ft}^3$ ($4.3 \times 10^9 \text{ m}^3$). As observed

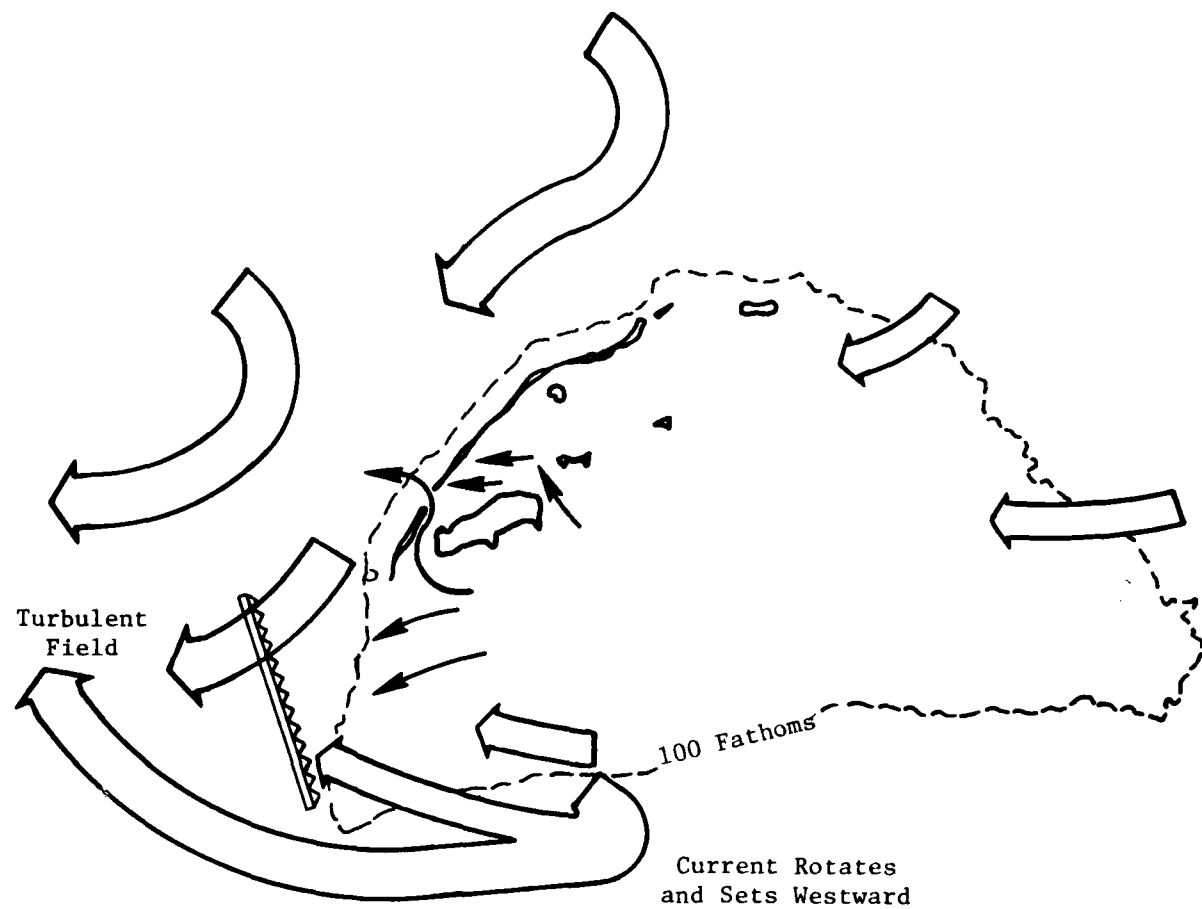

FIGURE 4. INFERRED LAGOON CIRCULATION (WESTERLY FLOW), JULY-AUGUST, 1965, KOPENSKY AND WENNEKENS, 1966

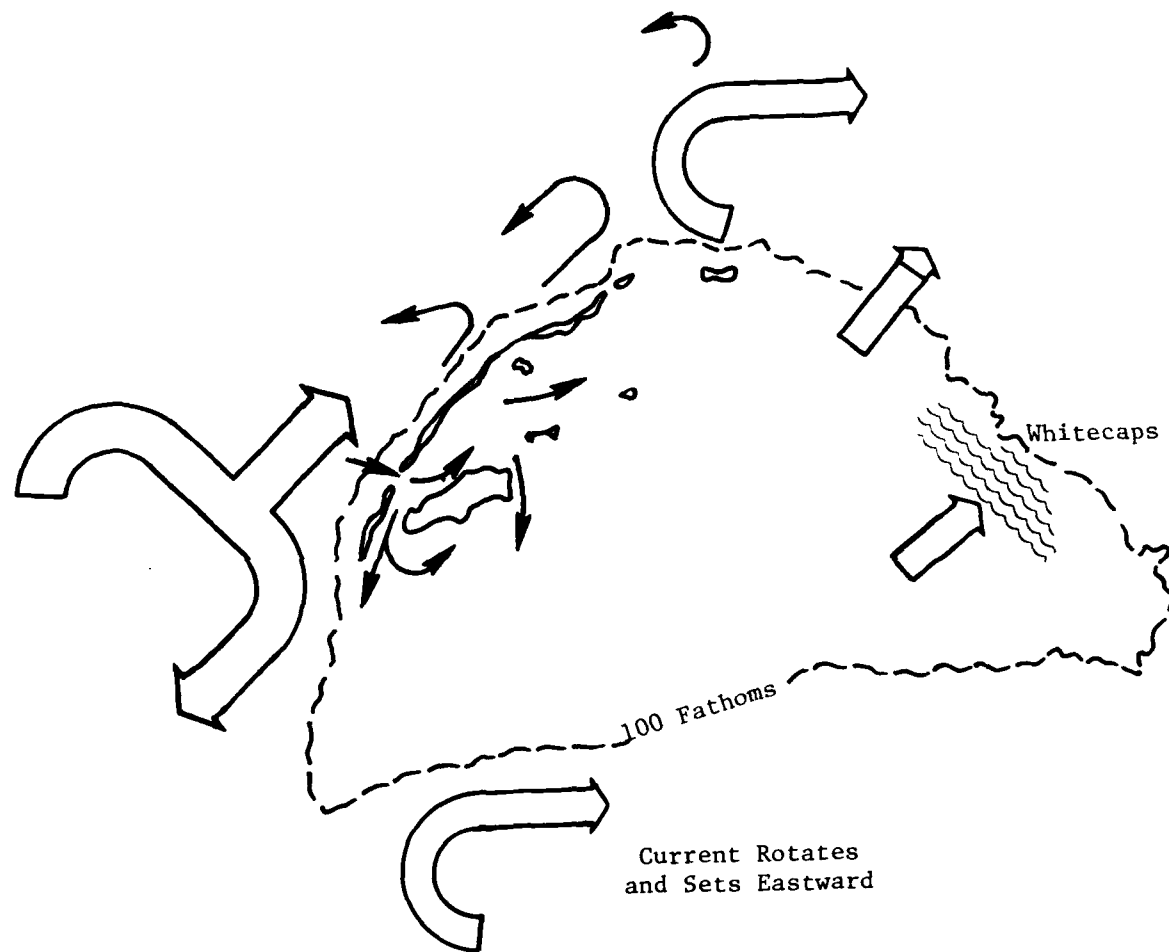

FIGURE 5. INFERRED LAGOON CIRCULATION (EASTERLY FLOW), JULY-AUGUST, 1965, KOPENSKY AND WENNEKENS, 1966

by Emery, ⁽³⁾ these coral heads influence the movement of sediments by blocking the current causing sand to be deposited on the upcurrent side and scouring the areas between the reefs. His examination showed these areas to be about half a fathom (0.9 meters) deeper than the surrounding floor and containing coarser sediment than the adjacent areas.

Micro-scale currents at the wharf observed by the divers when taking sediment samples were a light west-to-east deep current and an east-to-west surface current at 20-25 feet (6.1-7.6 meters) seaward from the center of the wharf. Off the west end of the wharf, the deep current direction was south to north (Figure 6). These observations were made at 1100 hours on July 25. ⁽¹⁰⁾ Water depths immediately off the wharf were 35 feet (10.5 meters). A trough of 45-50 foot (13.7-15.2 meters) depth was noted about 25 feet (7.6 meters) from the base of the wharf. ⁽¹⁰⁾

2.1.3.3 Water Quality Criteria/Standards

Limits on aqueous concentrations of 2,4-D and 2,4,5-T are classified as either criteria or standards.

The word "criterion" should not be used interchangeably with, or as a synonym for, the word "standard". The word "criterion" represents a constituent concentration or level associated with a degree of environmental effect upon which scientific judgment may be based. As it is currently associated with the water environment it has come to mean a designated concentration of a constituent that when not exceeded, will protect an organism, an organism community, or a prescribed water use or quality with an adequate degree of safety. On the other hand, a standard connotes a legal entity for a particular reach of waterway or for an effluent. A water quality standard may use a water quality criterion as a basis for regulation or enforcement, but the standard may differ from a criterion because of prevailing local natural conditions, such as naturally occurring organic acids, or because of the importance of a particular waterway, economic considerations, or the degree of safety to a particular ecosystem that may be desired.

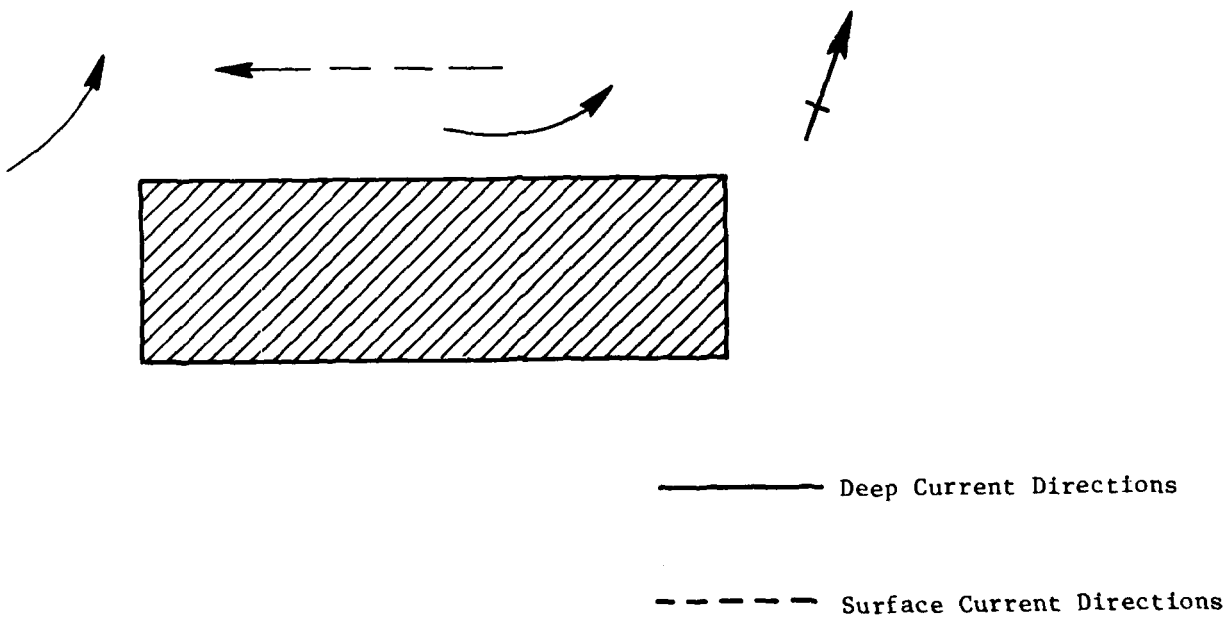
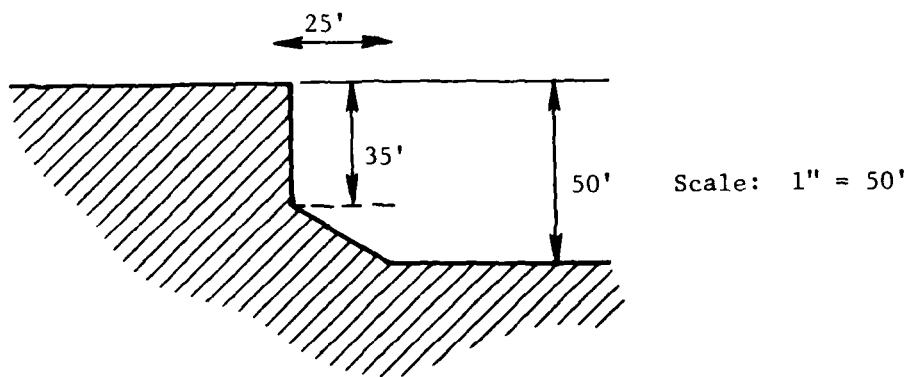

FIGURE 6 . MICROSCALE CURRENT DIRECTIONS AT THE MAIN WHARF, JULY, 1977

Water quality criteria are not intended to offer the same degree of safety for survival and propagation at all times to all organisms within a given ecosystem. They are intended not only to protect essential and significant life in water, as well as the direct users of water, but also to protect life that is dependent on life in water for its existence, or that may consume intentionally or unintentionally any edible portion of such life. ⁽¹³⁾

The criteria levels for domestic water supply incorporate available data for human health protection. Such values are different from the criteria levels necessary for protection of aquatic life. The interim primary drinking water regulations ⁽¹⁴⁾, as required by the Safe Drinking Water Act ⁽¹⁵⁾, incorporate applicable domestic water supply criteria. Where pollutants are identified in both the quality criteria for domestic water supply and the Drinking Water Standards, the concentration levels are identical. Water treatment consisting of flocculation, settling, and softening may not significantly effect the removal of certain pollutants, (such as the components of Orange Herbicide).

The ideal data base for aquatic life criteria application regarding Orange Herbicide would be information on a large number of tropical marine species common to the Johnston Atoll area over their entire life span and that of succeeding generations. Unfortunately, these data do not exist. Most of the available toxicity data on both acute and subacute effects are for freshwater organisms. These were obtained at temperatures below those typical of the Johnston Island environment or represent time frames of less than the organism's entire life span. Furthermore, independent environmental variables other than temperature have been found to be of importance in determining the toxicity of 2,4-D, 2,4,5-T or mixtures thereof.

The Environmental Health Laboratory at Kelly AFB, TX conducted bioassay tests in which Orange Herbicide was mixed with water at a theoretical concentration of 200 ppm. It was found that most of the herbicide rapidly sank to the bottom of the tank. None of the test organisms showed any adverse effects after two weeks exposure; however, all of the fish died within 24 hours at a concentration of 20 ppm in a similar experiment but with continuous agitation of the water. ⁽¹⁶⁾ Subsequent studies indicated that, in order to establish a dose/response relationship for the organism, some circulation of the water was necessary.

A second determinant of toxicity is the actual chemical form of the herbicide in water. The derivatives of 2,4-D and 2,4,5-T used in Orange Herbicide hydrolyze to the respective acids at varying rates. For ocean water, in studies conducted by the Air Force, 90 percent of the esters were hydrolyzed within 7 days. Toxicity of the acids is decidedly lower than the corresponding esters probably because of polarity influences on uptake mechanisms.⁽¹⁶⁾ The many confounding effects make it difficult to apply a rational criterion which would protect all the potentially exposable organisms. Tests by the EHL Kelly AFB, TX on artificial sea water systems produced marked differences between the theoretical concentration due to solubility effects. (Thus, static bioassay results found in the literature which are based on theoretical added concentrations of Herbicide may indicate a low toxicity (high side bias); the actual concentrations of HO in solution producing acute or subacute effects would be much lower).

The effect of temperature on organism response has received limited attention. Only one study was located which even stated the temperature at which the tests were conducted. This showed a strong temperature dependence, although only two temperatures, 17 and 20 C, were evaluated.⁽¹⁶⁾

The philosophy of EPA in assigning criteria has been to employ a safety factor to protect all life stages of the test organism in waters of varying quality, as well as to protect associated organisms within the aquatic environment that have not been tested and that may be more sensitive to the test constituent. Application factors have been used to provide the degree of protection required. Safe levels for certain chlorinated hydrocarbons and certain heavy metals were estimated by applying an 0.01 application factor to the 96 hour LC₅₀ value for sensitive aquatic organisms.

A listing of available acute and subacute bioassay data is contained in Tables 1 and 2. In addition, McKee and Wolf presented the following discussion concerning 2,4-D.⁽¹⁷⁾

TABLE 1. ACUTE TOXICITY DATA FOR 2,4-D, 2,4,5-T AND DERIVATIVE ACIDS, SALTS, ESTERS, AMINES, AND ETHERS^(a)

Test Compound	Test Organism	Test Conditions	Dose (mg/l)	Response	Comments	Reference
2,4-D (DMA)	Fathead minnow		355	96 hr TL ₅₀		16
2,4-D (DMA)	Bluegill		177	96 hr TL ₅₀		16
2,4-D (DMA)	Channel catfish	17 C	193	96 hr TL ₅₀		32
2,4-D (DMA)	Channel catfish	29 C	125	96 hr TL ₅₀		39
2,4-D; 2,4,5-T ester (GD)	Fathead minnow	Freshwater	3.4	48 hr LC ₅₀	14 ppm TCD	15
2,4-D (NBE)	Fathead minnow	Freshwater	2.8	48 hr LC ₅₀		16
2,4,5-T (NBE)	Fathead minnow	Freshwater	5.0	48 hr LC ₅₀		16
2,4-D	Fathead minnow	Freshwater	270	48 hr LC ₅₀		16
2,4,5-T	Fathead minnow	Freshwater	333	48 hr LC ₅₀		16
2,4-D (NBE)	Shrimp	Saltwater	5.6	48 hr LC ₅₀		16
2,4,5-T (NBE)	Shrimp	Saltwater	33	48 hr LC ₅₀		16
2,4-D (PGBE)	Daphnia magna	Freshwater	0.1	48 hr TL ₅₀		33
2,4-D (PGBF)	Seed shrimp	Freshwater	0.3	48 hr TL ₅₀		33
2,4-D (PGBE)	Scud	Freshwater	2.6	48 hr TL ₅₀		33
2,4-D (IGBE)	Sowbug	Freshwater	2.2	48 hr TL ₅₀		33
2,4-D (PGBE)	Glass shrimp	Freshwater	2.7	48 hr TL ₅₀		33
2,4-D (IOE)	Bluegill		10-31	48 hr TL _m	Obtained from 3 manufacturers	34
2,4-D (PCBE)	Bluegill		17	48 hr TL _m		34
2,4-D (BOEE)	Bluegill		1.4	48 hr TL _m		34
2,4-D (PGBE)	Fish	Saltwater	0.3	48 hr TL _m		35
2,4-D (AAS)	Bluegill		435-840	48 hr LC ₅₀		35
2,4-D (DMA)	Bluegill		166-458	48 hr LC ₅₀		36
2,4-D (IOE)	Bluegill		8.8-59.7	48 hr LC ₅₀		36
2,4-D (DMA)	Fathead minnow		10	96 hr LC ₅₀		36
2,4-D (AA)	Fathead minnow		5	96 hr LC ₅₀		36
2,4-D (AS)	Fathead/bluegill		2	4 Mo. LC ₁₀	Oil soluble	36
2,4-D (PGBE)	Fathead/bluegill		2	4 Mo. LC ₁₀		36
2,4-D (EGBE)	Fathead/bluegill		2	72 hr LC ₅₀		36
2,4-D (APE)	Bluegill		1.4	48 hr LC ₅₀		36
2,4-D (NBE)	Bluegill		1.3	48 hr LC ₅₀		36
2,4-D (IPE)	Bluegill		1.1	48 hr LC ₅₀		36
2,4-D (BOEE)	Fish	Saltwater	5	48 hr TL _m		36
2,4-D (PGBF)	Fish	Saltwater	4.5	48 hr TL _m		35
2,4-D	Fish		100	Threshold conc. for mortality		17
2,4-D	Perch		75	Threshold conc. for mortality		17
2,4,5-T	Perch		55	Threshold conc. for mortality		17
2,4,5-T	Bleak		60	Threshold conc. for mortality		17

(a) (DMD) = dimethylamine; (NBE) = normal butyl ester; (PGBE) = propylene glycol butyl ether; (IOE) = isooctylester; (BOEE) = butoxyethylester; (AAS) = alkanolamine salt; (AA) = acetamide; (AS) = amine salt; (IPE) = isopropyl ester.

(b) See literature cited for references.

TABLE 2. SUB-LETHAL EFFECTS OF 2,4-D DERIVATIVES
UPON AQUATIC ANIMALS^(a)

Test Compound	Test Organism	Dose	Response
Butoxyethanol ester	Oyster	3.75 ppm (96 hrs)	50% Decrease in shell growth
Butoxyethanol ester	Shrimp	1 ppm (48 hrs)	No effect
Butoxyethanol ester	Phytoplankton	1 ppm	16% Decrease in CO ₂ fixation
Dimethylamine	Oyster	2 ppm (96 hrs)	No effect on shell growth
Dimethylamine	Shrimp	2 ppm (48 hrs)	10% Mortality or paralysis
Dimethylamine	Fish (salt water)	15 ppm (48 hrs)	No effect
Dimethylamine	Phytoplankton	1 ppm (4 hrs)	No effect on CO ₂ fixation
Ethylhexyl ester	Oyster	5 ppm (96 hrs)	38% Decrease in shell growth
Ethylhexyl ester	Shrimp	2 ppm (48 hrs)	10% Mortality or paralysis
Ethylhexyl ester	Fish (salt water)	10 ppm (48 hrs)	No effect
Ethylhexyl ester	Phytoplankton	1 ppm (4 hrs)	49% Decrease in CO ₂ fixation
PGBE ester	Oyster	1 ppm (96 hrs)	39% Decrease in shell growth
PGBE ester	Shrimp	1 ppm (48 hrs)	No effect

(a) Source: Reference 16.

"In laboratory tests, the lowest concentration of 2,4-D to cause mortality of fish was 100 mg/l, the threshold value of toxicity to perch and bleak (Alburnus Lucious) was 75 mg/l. However, certain esters and amines of 2,4-D have been found to be more toxic and, particularly in still, shallow water, may harm fish at dosages used for weed control. Fingerling bluegills suffered losses of up to 40 and 100 percent from concentrations of 1 and 5 mg/l, respectively, of the butyl ester. The isopropyl ester was somewhat less toxic but caused complete mortality of bluegills at 10 mg/l, as did the alkalolamine at 40 mg/l. A few fish also died during a 4-day exposure to 4 mg/l of the latter material. The sodium salt was not observed to kill small rainbow trout below a concentration of 112 mg/l.

The Fish and Wildlife Service tested a large number of phenoxyacetic acids and related compounds in rough screening studies in Lake Huron water at 12 C. Trout and bluegill were killed but sea lamprey were unaffected by 2,4-dichlorophenoxyacetic acid, butyl ester during a 24-hour exposure to 5 mg/l.

Fish-food organisms vary in sensitivity to the derivatives of 2,4-D. Tests with the isopropyl ester showed that losses of over 25 percent were sustained by crustaceans at 0.1-0.4 mg/l, insects at 0.4-2.0 mg/l, and snails at 2.4-3.3 mg/l. These animals were more resistant to poisoning by the mixed propylene glycol and butyl esters of 2,4-D, and certain species of insects and snails were not killed at 6.6 mg/l.

It was found that the safe concentration to minnows was 1500 mg/l and for sunfish and catfish 500 mg/l. Some mortality of bream and bass occurred at 100 mg/l and of carp at 65 mg/l. A concentration of the sodium salt of 2,4-D of 260 mg/l was not toxic to carp.

A mixture of neutral aromatic oils (57 percent), 2,4-D (12.5 percent), emulsifiers (8 percent), and water (to 100 percent) was toxic to three-month-old rainbow trout at a concentration of 3.0 mg/l over a 24-hour period, and at 2.2 mg/l over a 48-hour period.

A commercial weed killer that combines 6.25 percent 2,4-D and 6.25 percent 2,4,5-T with propylene glycol, butyl ether esters, and inert ingredients, in concentrations of 50 mg/l or more caused the test fish to become immediately distressed. In a 72-hour period, a 25-percent kill occurred at 10 mg/l, but no fish died at 5 mg/l.

It is clear that few saltwater species have been assayed and perhaps no tropical saltwater species have been tested. For short term (shorter than 24 hours) exposure, it can be assumed that less than one-half of an ester form of 2,4-D or 2,4,5-T added to water will be hydrolyzed to the less toxic acid form. Furthermore, the offsetting effect of higher temperatures should more than compensate for the lower toxicity of the hydrolyzed fraction. The 48 hour LC_{50} or TL_m values for saltwater fish species exposed to 2,4-D ranged from 0.3 mg/l using the PGBE derivative to 5 mg/l using the BOEE derivative. The Air Force's data using actual HO or normal butyl esters, is about the same, although a freshwater test organisms, the fathead minnow, Pimephales promelas, was used. Using the EPA methodology of determining a "safe" concentration as 1 percent of the 96 hr LC_{50} , a value between 0.01 and 3.6 mg/l 2,4-D results for a water quality criterion, ignoring the possible inappropriateness of the test organisms or test conditions.

The toxicity of 2,4,5-T to aquatic species has been studied to a much lesser degree than the toxicity of 2,4-D. Comparative studies on 2,4-D and 2,4,5-T toxicity have been conducted by the Air Force on a number of species. Freshwater tests on fathead minnows showed the same trend as for 2,4-D, namely, that ester formulations were much more toxic than the acids. Measured toxicities of 2,4,5-T were 20-50 percent lower than for 2,4-D, however, the TCDD content of the 2,4,5-T tested was not stated. In tests using actual Herbicide Orange, the toxicity was intermediate to the two individual components.

Tests on other varieties of fish have been performed that show the opposite trend. Perch exhibited slightly greater toxicity response to 2,4,5-T. Again, the TCDD content was not given.

Finally, saltwater shrimp comparison tests showed the normal butyl ester of 2,4,5-T to be significantly less toxic than the NBE ester of 2,4-D.

The range of acute toxicities of 2,4,5-T observed in the data is 5.0 to 333 mg/l. Using the EPA methodology of determining "safe" concentrations as one percent of the 96 hr LC_{50} , a value of between 0.05 and 3.3 mg/l results for a water quality criterion.

Both the National Institute for Occupational Safety and Health (NIOSH) Registry and the Water Quality Characteristics of Hazardous Materials assign aquatic toxicity range ratings of 1-10 ppm for 2,4-D and 2,4-T (5,43). Concentrations of 2.5 mg/l for each of the components (5 mg/l of HO) has been selected as the criterion concentration.

According to the literature, pure 2,4-D and 2,4,5-T are considered to present a moderate toxicity to humans.

An extensive study of the literature on the human health and toxicity of the major and minor constituents of Herbicide Orange has been conducted by the National Academy of Sciences.⁽⁴³⁾ Judgements were made on a wide variety of organic substances relative to their carcinogenicity or the available information that would permit estimation of the "no observed adverse effect level".

After a substance had been identified as a carcinogen, the risk to man was expressed as the probability that cancer would be produced by continued daily ingestion over a 70 year lifetime of 1 liter of water containing 1 µg/l of the substance. Assumptions required in the calculation were the conversion of the standard human dose to the physiologically similar dose in the animal and the application of an exponential risk model relating dose to effect.

2,4-Dichlorophenoxyacetic acid toxicity data for man and other terrestrial species were reviewed to determine permissible intake levels. Observations in man are primarily *ex post facto* judgements of accidental or intentional (suicidal or medical) ingestion. Poisoning and death have been attributed to ingestion of dosages ranging from 67 to 100 mg/kg. Subjects in two other studies took or were exposed to lesser quantities or similar quantities over longer time periods with no harmful effects.

Observations in other species supported the moderate toxicity designation. LD₅₀ values of 100-541 mg/kg were found for rats, mice, guinea pigs, chicks, and dogs. Salts and esters of 2,4-D showed an even lower degree of acute toxicity than the acid.

Subchronic and chronic effects have been measured using rats and dogs. Experiments with rats showed no adverse effect levels ranging from 30 to 1,250 mg/kg and those with dogs ranged from 20 to 500 mg/kg.

The results of these studies were analyzed to determine the daily no adverse effect doses. These were found to be up to 62.5 mg/kg/day and 10 mg/kg/day in rats and dogs, respectively. Based on these data, the acceptable daily intake for humans was calculated to be 0.0125 mg/kg/day. The NAS report stated that the substantial disagreements in the results of the subchronic and chronic toxicity studies were cause for concern and caution and that additional study is warranted. These deficiencies were considered in the determination of the no adverse effect level from drinking water shown in Table 4.

Toxicity data on 2,4,5-trichlorophenoxy acetic acid and 2,3,7,8-tetrachloro-p-dibenzodioxin were considered together since most of the 2,4,5-T preparations tested contained TCDD at 1-80 ppm. A few studies have been conducted with TCDD "free" material (< 0.05 ppm).

Observations of toxicity in man depend on the TCDD content of the test material. Two studies in which 2,4,5-T containing low concentrations of TCDD was used failed to produce toxic effects in the concentration range of 1.6-8.1 mg/day. Another study where contaminated 2,4,5-T was used produced cases of moderate to severe chloracne and several cases of porphyria.

Toxicity testing results on other species likewise depend on the TCDD content. Early data on 2,4,5-T show oral LD₅₀ values for male rats, male mice, guinea pigs, and chicks were 500, 389, 381, and 310 mg/kg, respectively. TCDD contents were unknown. Testing of TCDD alone established its extreme toxicity as shown by LD₅₀ values ranging from 0.6 to 115 µg/kg, depending on species.

Subchronic and chronic effects of 2,4,5-T and TCDD have been observed in relatively short-term studies on rats, mice, dogs, and guinea pigs. Effects most often observed included lesions, bone marrow irregularities, degenerative liver and thymus changes porphyria, serum enzyme changes and weight loss. 2,4,5-T doses eliciting adverse effects ranged from 2 mg/kg/day for dogs to 100 mg/kg/day for rats. TCDD doses yielding responses were as low as 0.1 µg/kg 5 days a week for 13 weeks.

The conclusions reached by the NAS report were that contamination of 2,4,5-T with TCDD greatly increases the toxicity of the mixture from moderately toxic to very toxic. No adverse effect doses for 2,4,5-T were 10 mg/kg/day for dogs and mice and up to 30 mg/kg/day for rats and for TCDD were 0.01 $\mu\text{g}/\text{kg}/\text{day}$ in rats. Acceptable daily intakes for humans were calculated as 0.1 mg/kg/day for 2,4,5-T and 10^{-4} $\mu\text{g}/\text{kg}/\text{day}$ for 2,4,5-T and 10^{-4} $\mu\text{g}/\text{kg}/\text{day}$ for TCDD. The lack of data on long term toxicity and the substantial differences in toxicity values for 2,4,5-T due to varying degrees of TCDD contamination were cited as reasons for conservative estimation of permissible drinking water concentrations, shown in Table 3. Maximum contaminant levels as contained in the Drinking Water Standards and in the 1976 Water Quality Criteria are shown for comparison. (13,15)

Ambient water standards are applied at the point of withdrawal for supply which in this case is the saltwater intake (site WS), while drinking water standards are applicable at the delivery end of the system (site P1). There are two additional factors which serve to alter the normally encountered conditions in a drinking water supply. First, the production of freshwater is intermittent. Higher than allowable levels at the saltwater intake are not of concern if freshwater is not being produced on a given day. Second, freshwater on Johnston Island is produced by distillation. The boiling points of 2,4-D, and 2,4,5-T acids are related derivatives are all greater than 160 C. (18) Therefore, the fraction of distillable HO at the process temperature is certainly less than 50 percent of the concentration on the saltwater side of the system. (See also Section 4.1.3 for more detailed discussion of these points).

Since the water quality criteria represent lifetime consumption levels, the short term exposure levels could conceivably be much greater than the average and still produce no effects if the subsequent exposure is correspondingly lower to offset the initial dose. The tour of duty for most military personnel is one year; however, some of the civilians have been on the island for upwards of 15 years. It is not expected that

TABLE 3. WATER QUALITY CRITERIA/STANDARDS--
DRINKING WATER

Compound	Concentration in Water (µg/l)	Uncertainty or Safety Factor (a)	Reference ^(b)
2,4-D	100 ^(c) (Approval limit)	500	15
	100 ^(d) (MCL)	--	13
	87.5 ^(e) (No effect level)	1000	37
	4.4 ^(f) (No effect level)	1000	37
2,4,5-T	700 ^(e) (No effect level)	100	37
	35 ^(f) (No effect level)	100	37
TCDD	7×10^{-4} ^(e) (No effect level)	100	37
	3.5×10^{-5} ^(f) (No effect level)	100	37

- (a) The uncertainty or safety factor is introduced to reflect the amount of information available on a specific contaminant. An uncertainty factor of 100 represents a good set of chronic oral toxicity data available for some animal species while a factor of 1000 was used with limited chronic toxicity data or when the only data available were from inhalation studies.
- (b) See literature cited for references.
- (c) Represents lifetime no adverse effects level assuming that 20 percent of the safe intake is from water. Standard man equivalent to 70 kg and 2 liter/day water consumption used.
- (d) A maximum contaminant level (MCL) means the maximum permissible level of a contaminant in water which is delivered to the tap of the user.
- (e) No adverse effect level assuming 20 percent of acceptable daily intake is supplied by water. Same standard conditions as in (a).
- (f) No adverse effect level assuming 1 percent of acceptable daily intake is supplied by water. Same standard conditions as in (a).

the lifetime consumption would be approached by anyone on Johnston Island. Therefore, the water quality criteria are probably conservative in estimating risk.

The most stringent standard appears to be the National Interim Primary Drinking Water Standard at 0.1 mg 2,4-D/l.

Other water quality criteria pertain to the organoleptic properties of 2,4-D and its breakdown products, as well as potential non-OH related project effects such as oil and grease, turbidity, and reduced dissolved oxygen concentrations.

It has been reported that 2,4-D acid was decomposed in water exposed to the sun into 2,4-dichlorophenol, 4-chlorocatechol, 2-hydroxy-4-chlorophenoxyacetic acid, and 1,2,4-benzenetriol. Taste and odor thresholds for chlorinated aromatic hydrocarbons are very low.

McKee and Wolf report the taste threshold for 2,4-D as 0.01 mg/l, whereas the same concentration of dichlorophenol derivatives gives noticeable tastes.⁽¹⁷⁾ Several investigators have reported the taste or odor threshold concentrations for various chlorinated phenols. For 2,4-dichlorophenol the reported taste values are 0.008 to 0.02 mg/l and the odor values range from 0.00065 mg/l at 30°C to 0.0065 mg/l at 60°C.^(19,20) Spills from 2,4-D manufacturing operations have reportedly produced unpleasant tastes in drinking water at dilution ratios as high as 10,000,000:1.⁽¹⁷⁾

Turbidity (suspended solids) influences on fish life are divided into those whose effect occurs in the water column or those whose effect occurs following sedimentation to the bottom of the water body. Five general effects on fish and fish food populations have been noted:

- direct effects on swimming fish by killing them or impairing physiological functions
- preventing the successful development of eggs and larvae
- modifying natural movements and migration
- reducing the availability of food
- blanketing of bottom sediments causing damage to invertebrates and spawning areas and increasing benthic oxygen demand.

Conversely, a partially offsetting benefit of suspended matter in water is the sorption of organics such as herbicides onto particles which leads to more rapid settling.⁽¹³⁾ However, experiments conducted to ascertain the sorption properties of 2,4-D ester and sodium salt showed very low sorption capacity for three clay minerals (bentonite, kaolinite, and illite) and very good sorption for dry coral. Desorption properties of contaminated coral in seawater were not investigated.⁽²¹⁾

The criterion proposed by the EPA relates primarily to freshwater fish and other aquatic life and states that "settleable and suspended solids should not reduce the depth of the compensation point by more than 10 percent from the seasonal norm".⁽¹³⁾ The compensation point is defined as that depth where the rates of photosynthesis and respiration are equivalent or approximately the depth at which one percent of the incident light remains.

The water quality criterion for dissolved oxygen similarly pertains to freshwater aquatic life. A minimum value of 5 mg O₂/l is given.⁽¹³⁾

Effects of oil and grease on ocean communities range from inhibition of oxygen transfer when heavy concentrations are present on the water surface to acute or sublethal toxicity to specific compounds present in the oil. Because of the range of possible compositions, criteria have been specified with respect to bioassay techniques on important species:

For domestic water supply: Virtually free from oil and grease, particularly from the tastes and odors that emanate from petroleum products.

For aquatic life:

- 0.01 of the lowest continuous flow 96-hour LC₅₀ to several important freshwater and marine species, each having a demonstrated high susceptibility to oils and petrochemicals.
- Levels of oils or petrochemicals in the sediment which cause deleterious effects to the biota should not be allowed.
- Surface waters shall be virtually free from floating non-petroleum oils of vegetable or animal origin, as well as petroleum derived oils.

2.1.3.4 Existing Water Quality

The salt waters around Johnston Island and the freshwater system have been monitored for the presence of 2,4-D and 2,4,5-T since 1973. Eight locations, including an offshore control, have each been sampled a number of times. Table III-13 is a summary of baseline water quality data gathered by the Air Force from 1973 to 1977. The data show occasional instances of HO being detected at most of the locations. Of special significance to the disposal operation are those locations which were also sampled by BCL during Operation Pacer HO. These include the wharf, the south side of the island, the offshore area near the herbicide storage yard, the saltwater intake and the distillation plant. Corresponding site codes used in the Pacer HO operation are WF, WO, WD, WS, and P1, respectively (Figure 7).

The maximum concentrations historically observed by the Air Force in the offshore area near the Herbicide storage were on the order of 3 μg 2,4-D/liter and 0.6 μg 2,4,5-T/liter and those near the saltwater intake were 2.3 and 0.7 $\mu\text{g}/\ell$, respectively. The other two offshore sites exhibited maximum concentrations below 0.5 $\mu\text{g}/\ell$. Samples taken in the distillation plant never showed measurable concentrations, yet one sample from the storage reservoir showed 1.6 $\mu\text{g}/\ell$ of 2,4,5-T. This number is not only much higher than any of the other concentrations from the reservoirs, but also reverses the trend for the 2,4-D concentrations to be greater than those for 2,4,5-T.

Data gathered by Battelle during the baseline monitoring period from July 24 to July 27 shows 100 percent of all samples analyzed below the quantitative detection limit of 0.2 $\mu\text{g}/\ell$ (ppb) (Table 4).

It can therefore be concluded that the water environment at Johnston Island has in the past been affected by the storage of Orange Herbicide, but that, immediately prior to the dedrum/transfer operation, the water showed no serious degradation in quality from the herbicide.

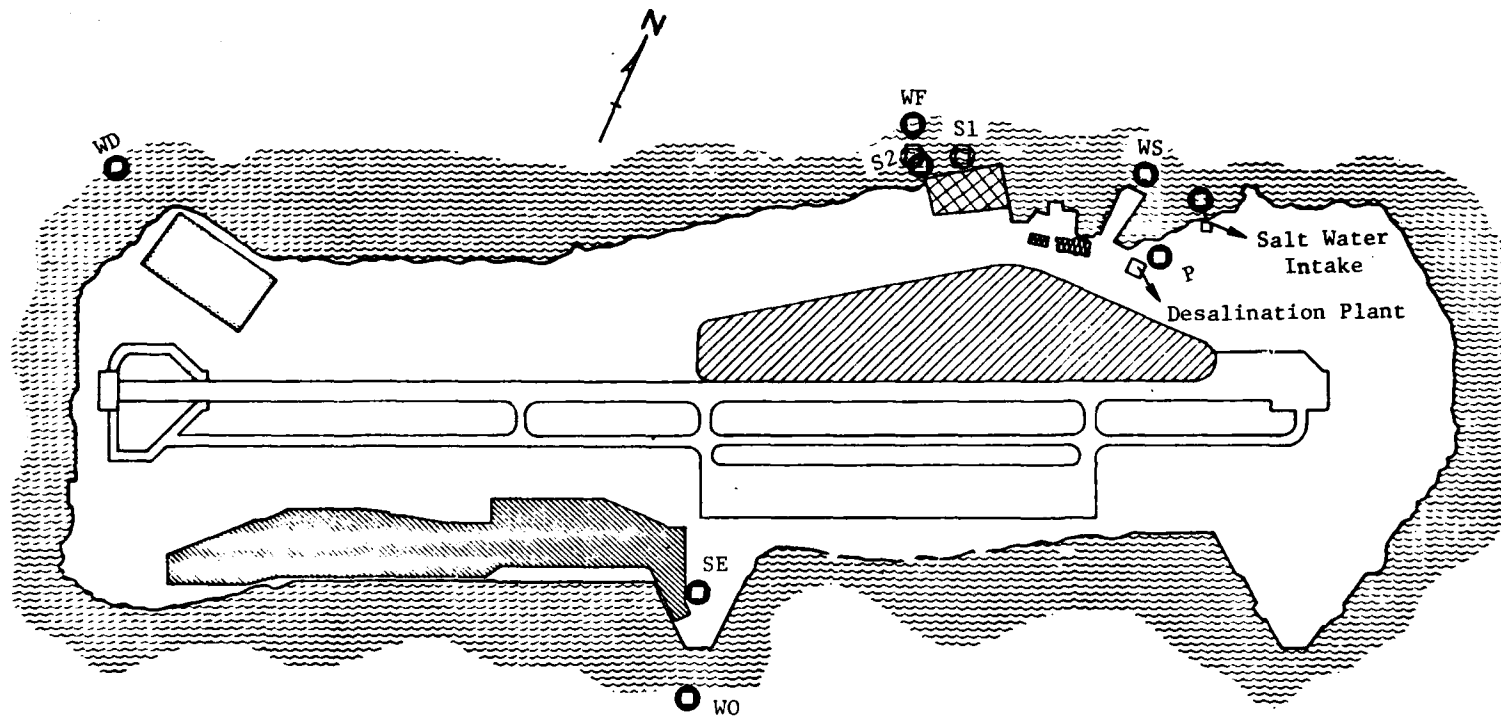

- | | |
|---|-----------------------------------|
| ● Water Sampling Sites - (WD,WS,WF,WO,
P,SE) | ▨ Johnston Island Crew Facilities |
| ◐ Sediment Sampling Sites | ⊠ Wharf |
| ■ Analytical Building | ▤ Dedrum Area |
| ▧ Red Hat Area | |

FIGURE 7. WATER AND SEDIMENT SITES

TABLE 4. OPERATION PACER HO DATA SUMMARY-WATER
PRE-OPERATIONAL

Location	No. Samples	Maximum in PPB		Minimum in PPB		Positive Average in PPB		Percent Positive		Percent Trace		Percent N.D.	
		D	T	D	T	D	T	D	T	D	T	D	T
WS saltwater intake	4	<.1	<.1	<.1	<.1	--	--	0	0	0	0	100	100
WF wharf	4	<.1	<.1	<.1	<.1	--	--	0	0	0	0	100	100
WO wastewater outfall	3	<.1	<.1	<.1	<.1	--	--	0	0	0	0	100	100
WD downwind dedrum	1	<.1	T	<.1	T	--	--	0	0	0	100	100	0
P1&P2 potable water	3	T	T	<.1	<.1	--	--	0	0	33	67	67	33
SE1&SE2 sewage	1	<.1	<.1	<.1	<.1	--	--	0	0	0	0	100	100
RW rainwater	0	--	--	--	--	--	--	--	--	--	--	--	--

14

Other environmental indicators measured were temperature and dissolved oxygen. The mean monthly water temperature for Johnston Island for July and August is 26.4° C. ^(11,12) The water temperatures measured by BCL during the baseline period were 26.8° C at the wharf, 26.1° C at the saltwater intake, and 26.4° C at the wastewater outfall. Dissolved oxygen concentrations at all the offshore sites were near saturation for an assumed chloride concentration of 15 ppt (parts per thousand). No values below the water quality criterion of 5 mg/ℓ were observed. Dissolved oxygen concentrations were lower in both the potable water and sewage samples as expected. Potable water composite samples showed mean oxygen concentrations of 6.0 ± 0.3 mgO₂/ℓ or 81 percent of saturation at 32° C. Sewage samples were nearly anaerobic measuring only 1.1 ± 0.2 mg/ℓ of oxygen at a temperature of 32.5° C

No acute adverse environmental effects in existing water quality were noted during the baseline monitoring.

2.1.4 Groundwater Quality

On Tuesday, August 25, two days after the dedrumming operation was completed, a 6 in. water sampling well was found in the barrel storage yard (Plate 2). The exact location is shown on the engineering drawings of the island and has since been filled in with coral. The well casing terminated flush with or just below the ground surface possibly permitting surface water to flow into the well. Therefore, it was judged not to be a good site for groundwater sampling. A sample of the water was nonetheless examined by smell and found to have a distinct odor of HO indicative of contamination. The water table was measured at the hole and found to be 9 feet 3 inches below the ground surface. This measurement was taken near a period of low tide.

The Air Force has monitored contaminants in test wells, as documented below:

Historical Groundwater Data Summary

<u>Location</u>	<u>TCDD Detection</u>		<u>Analyses</u>	
	<u>Limit (PPT)</u>		<u>Results</u>	
Well hole-center of herbicide area	0.37		ND	
Well hole-west side of herbicide area	0.24		ND	
	<u>Analyses Results, ng/l</u>			
	<u>2,4-D</u>		<u>2,4,5-T</u>	
	<u>Ester</u>	<u>Acid</u>	<u>Ester</u>	<u>Acid</u>
	<u>200*</u>	<u>100*</u>	<u>50*</u>	<u>20*</u>
Well hole-center of herbicide area	ND	44,000	ND	1,200
Well hole-west side of herbicide area	ND	77,000	ND	3,600

2.2 Biological Environmental Features of Johnston Atoll

2.2.1 Terrestrial Environment

The terrestrial environment of Johnston Atoll has been extensively studied.^(1,2) As a result, much is known about the plants and animals which inhabit the four islands of the atoll.

2.2.1.1 Plants

To date, 51 families, 109 genera, and 127 species of vascular plants have been identified from the four islands of Johnston Atoll^(1,2) (Table III-5). This number of plants is remarkable in view of the fact that only three species existed in 1923. These three plant species are believed to have reached the atoll by natural means, either by water currents, air, or birds. The majority of the remaining 124 species have been introduced by man. Undoubtedly, some of these introductions were intentional, others came as stowaways or adventives.

* Detection Limits, ng/l.

Materials from land clearing and dredging operations have increased the size of the two original islands and have made two new islands, thus bettering the opportunity for more plant species to become established. Disturbed soil coupled with the freedom from competition from established flora have created conditions suitable for the establishment of many plant species. Undoubtedly, because of the poor soil and climatic conditions, many of the ornamental species intentionally introduced by man would not survive if not frequently cared for.

Of the 38 species of vascular plants found on Akau Island a majority have been transplanted from Johnston Island. This man-made island was completed in 1964, and by September, 1967, 31 species were found there. Fimbristylis cymosa grew over most of the island and was the most predominant species. Other species which were common were Spergularis marina, Sesuvium portulacastrum, Eleusine indica, and Cynodon dactylon. A similar plant distribution was noted in November 1973.

To date, only 14 species of plants have been recorded from Hikina Island. The construction of this island was completed in 1964 and by September, 1967, five species of plants were found growing there. Only three of the five species were abundant, Fimbristylis cymosa, Sesuvium portulacastrum and Spergularis marina. Two additional species, Eleusine indica and Lepturus repens, were also present in 1969. The flora was found to be similar in 1973.

In 1923, only three plant species were known to be growing on Johnston Island. Early photographs of the island reveal that Lepturus repens was the dominant species. By 1967, 111 plant species were recorded from Johnston Island, many of which were under cultivation by residents. Major species were Pluchea carolenensis, Cenchrus echinatus and Casuarina equisetifolia. There are 54 species of plants which have been recorded from Sand Island. Only three species (Lepturus repens, Boerhavia repens, and Tribulus cistoides) were known to the original portion of Sand Island in 1923. Lepturus repens was the dominant species. By 1967, the number of plant species known to the original portion of Sand Island had increased

to 25. At this time the five most common species were Lepturus repens, Tribulus cistoides, Sesuvium portulacastrum, Boerhavia repens and Amaranthus viridis.

The man-made portion of Sand Island was completed in 1941. By 1967, 50 plant species had been recorded as growing on this portion of the island. The most common were Fimbristylis, Conyze, Sanchus, Cenchrus, Pluchea, Cynodon, Sesuvium, Euphorbia, and Scaevola. A similar distribution was found in November, 1973.

2.2.1.2 Invertebrates

The terrestrial invertebrate fauna of Johnston Atoll is not well known. Insects are the only member of the invertebrate fauna which have been studied to any extent. Insects totaling 68 species of 35 families are known from the four islands of Johnston Atoll (Table III-16).

2.2.1.3 Vertebrates

a. Fish

There are no freshwater fishes which inhabit the islands of Johnston Atoll.

b. Reptiles

Four species of reptiles are known from the terrestrial environment of Johnston Atoll. These species are Hemidactylus frenatus (house gecko), Hemidactylus garnotti (fox gecko), Lepidodactylus lugubis (mourning gecko) and Ablepharus boutonii poecilopleurus (snake eyed skink).

c. Birds

There are 56 bird species which are known to the islands of Johnston Atoll (Table III-17), which constitute a national bird refuge. These species belong to 10 orders, 19 families, and 38 genera. Twenty-

two species are classed as sea birds and 34 species are waterfowl, marsh, and land birds.

Of the 22 sea bird species recorded at Johnston Atoll, 12 are breeders, 3 are former breeders, and 7 are visitors (Table III-18). All of the 12 resident breeding species also nest in the Hawaiian Islands and other parts of the tropical Pacific. The three species which formerly bred at Johnston Atoll are Diomedea nigripes (Black-footed Albatross), Diomedea immutabilis (Laysan Albatross), and Sula dactylatra (Blue-faced Booby). The seven sea bird visitors to Johnston Atoll came from the north, south, and east Pacific.

The 34 species of waterfowl, marsh, and land birds recorded at Johnston Atoll are divided into five groups: regular migrants consisting of seven species, irregular visitors consisting of six species, stragglers consisting of two species, accidentals consisting of 16 species, and introductions consisting of three species (Table III-18).

The annual breeding and bird population cycles vary greatly among the bird species at Johnston Atoll. The sea birds breed during all seasons of the year (Figure 8). Nine of the 12 presently breeding sea-bird species breed during the spring and summer seasons. Thus, May through September is the peak breeding period for the sea birds of Johnston Atoll.

Many of the bird species known to Johnston Atoll leave during part of the year while others stay throughout the year. There is however, a population buildup for each species sometime during the year.

The breeding population of sea birds of the Atoll consists of 12 species. However, only five species are dominant in terms of total numbers (Figure 9). The Sooty Tern, with a mean population of 300,000 to 310,000 breeding birds during March, April, and May, makes up 95 percent or more of the total Atoll population between March and July. Possibly as many as 600,000 Sooty Terns used Johnston Atoll annually.

Red-footed Boobies, whose mean population ranges up to 3,750 birds, ranks second in sea bird numbers in winter and spring. Most of these birds are transients for only a few young are produced each year.

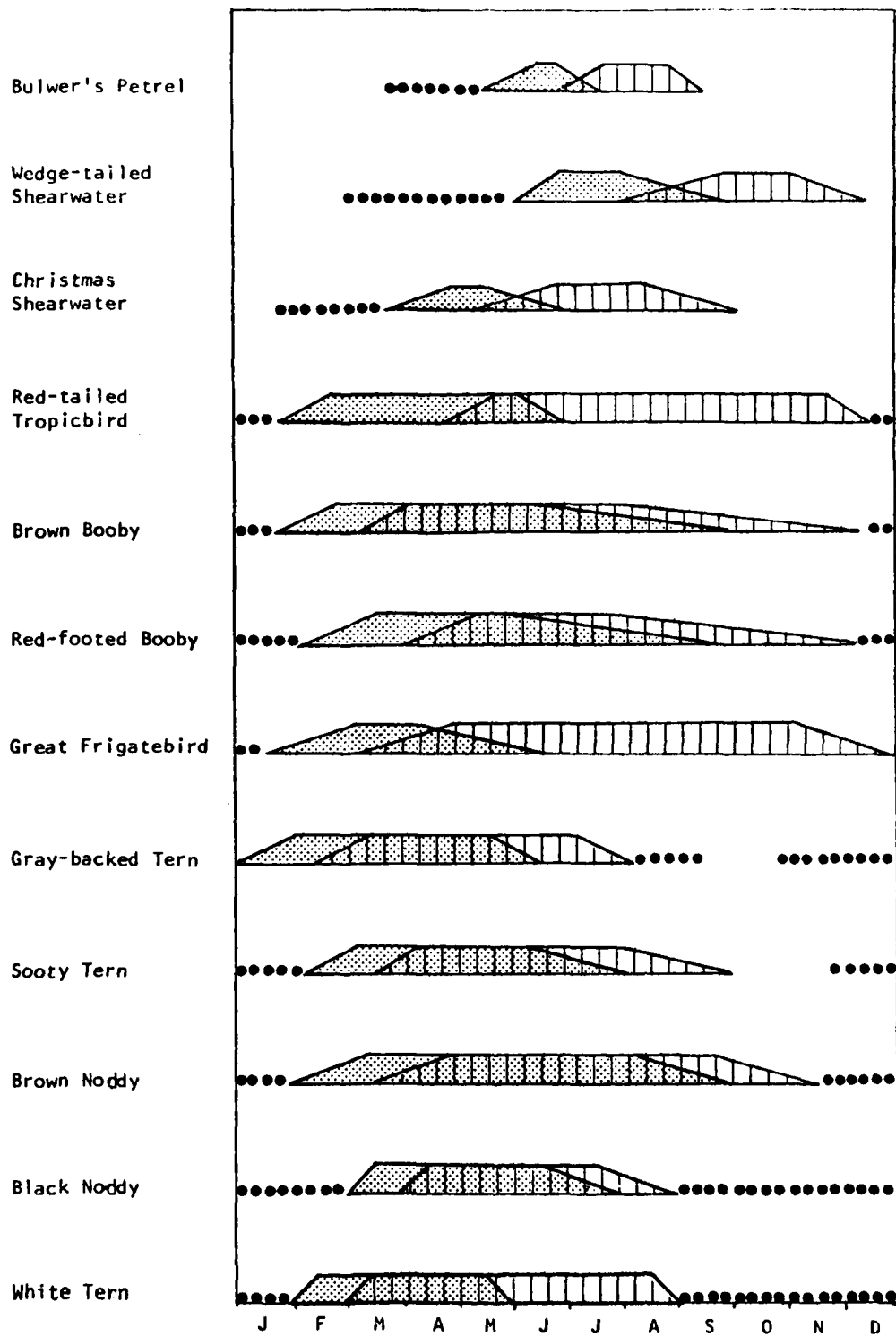

FIGURE 8. BREEDING CYCLES OF SEABIRDS AT JOHNSTON ATOLL: STIPPLED AREA REPRESENTS EGGS, BARRED AREA YOUNG, AND BLACK DOTS NONBREEDING BIRDS

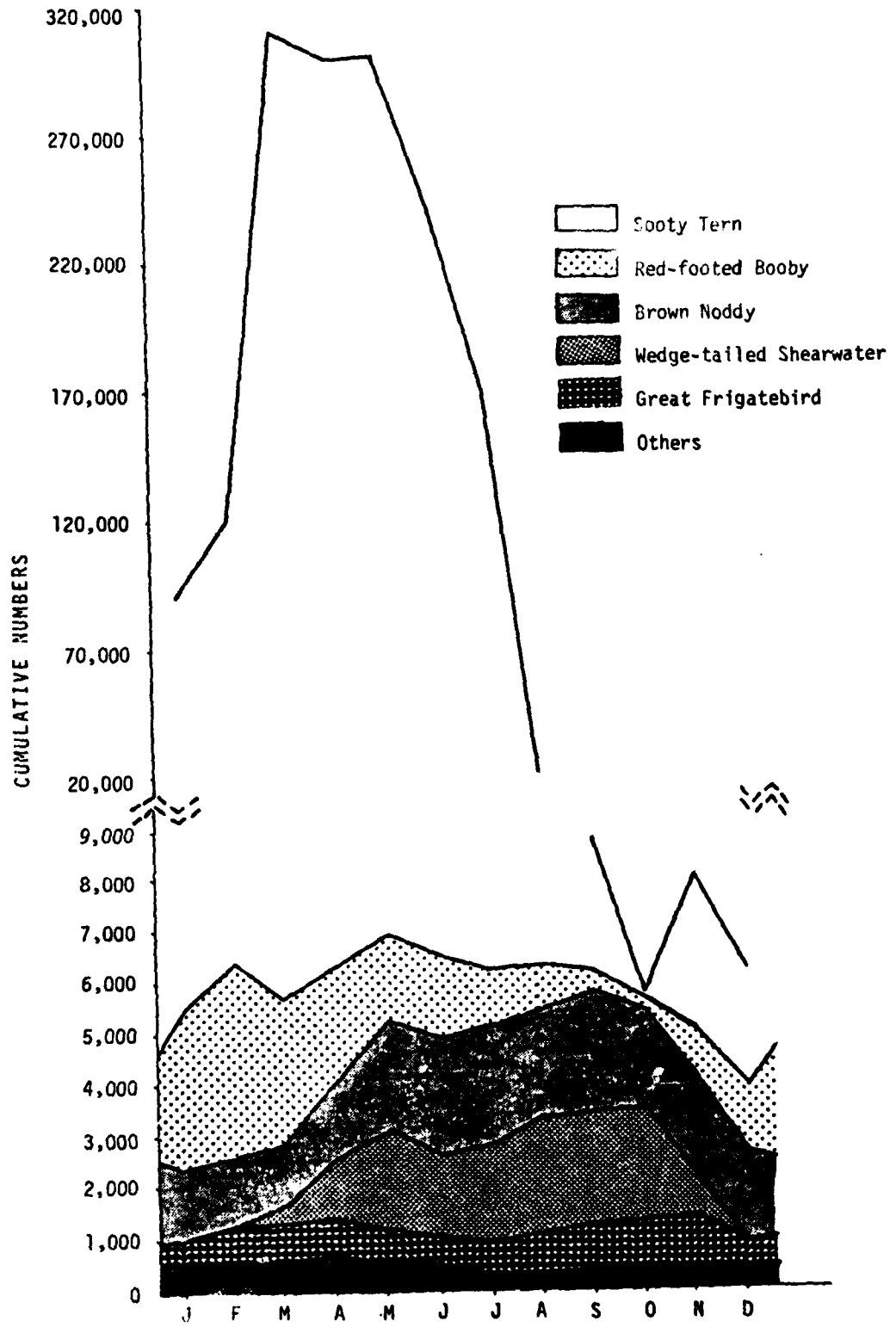

FIGURE 9. MONTHLY CUMULATIVE BIRD POPULATIONS, JOHNSTON ATOLL, 1963-1969

The Brown Noddy ranks third in mean population numbers. The Wedge-tailed Shearwater ranks fourth in numbers of adults using the Atoll but is present only from March to early December. The Great Frigatebird, with a main peak of 750 in March and April ranks fifth in population numbers. Mean monthly populations of all other species combined never totals more than 600 nor less than 300 birds.

Of the seven regular migrants, only the American Golden Plover, Wandering Tattler, and Ruddy Turnstone are known in all 12 months. Although the Wandering Tattler is present in low numbers throughout the year, American Golden Plovers and Ruddy Turnstones show peak populations of 120 and 100, respectively, in fall and mid-winter (Figure 10).

The four islands of Johnston Atoll vary with respect to size evaluation, soil, vegetation, and degree of human disturbance. Major differences exist in the ecological distribution of bird species between disturbed and non-disturbed islands. This is particularly true for the bird species which breed on the islands of the Atoll.

Fifty-two of the 56 bird species known to the Atoll are known to Sand Island. Of these 52 species, 44 are known from the original portion while 35 are known from the man-made part. Furthermore, 35 species are known from Johnston Island, while eight are from Akau Island and five are recorded from Hikina Island.

The bird populations of Akau, Kikina, and Johnston Islands are known to be small in comparison to that of Sand Island. The population cycles shown in Figure 8 are essentially those of the birds on Sand Island. During the spring and summer, Sooty Terns are most predominant species and nest on the bare ground over most of the island (Figure 11). The nesting areas for other species are shown in Figures 12 and 13. Brown Noddies nest on the ground around the perimeter of the island. Red-tailed Tropicbirds nest under low vegetation about the island. Wedge-tailed Shearwaters nest in burrows over much of the island. Brown Boobies nest on the ground on the southeast hill, the south edge, the northeast peninsula, and the southwest islet. Red-footed Boobies build their nests on the east hill, on the Tournefortia bush northeast of the transmitter buildings. Great Frigatebirds nest along the east hill and the south edge.

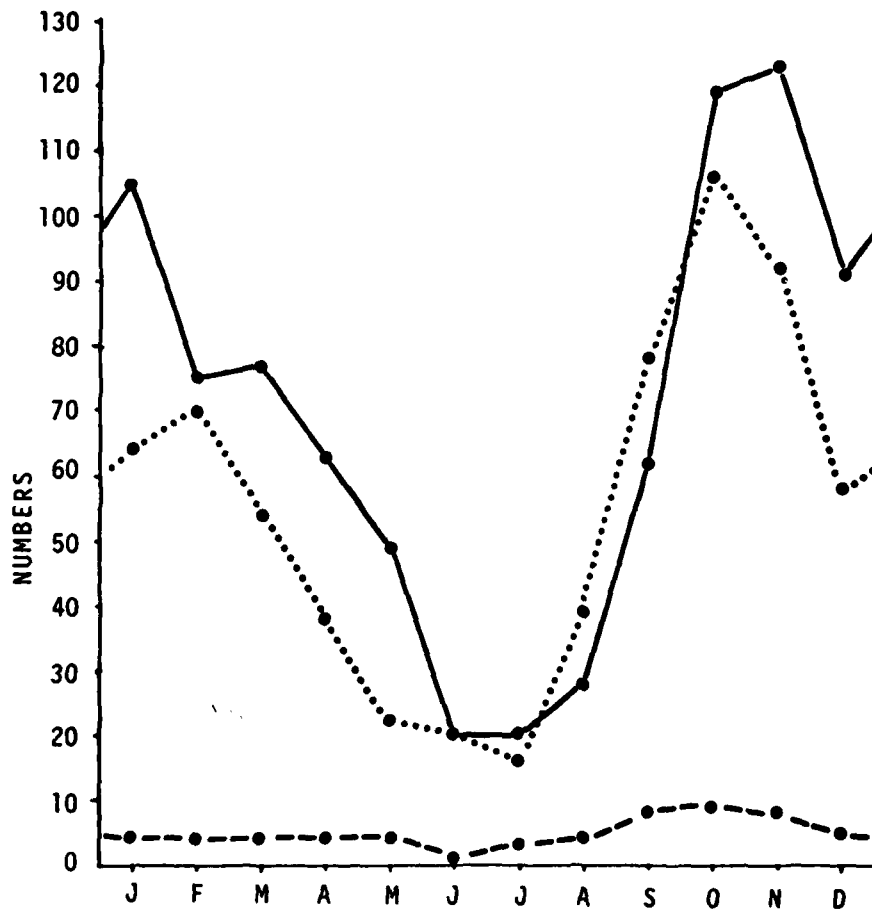

FIGURE 10. MONTHLY MEAN SHOREBIRD POPULATIONS FOR JOHNSTON ATOLL, 1963-1969; GOLDEN PLOVER (SOLID LINE), RUDDY TURNSTONE (DOTS), WANDERING TATTLER (DASHES)

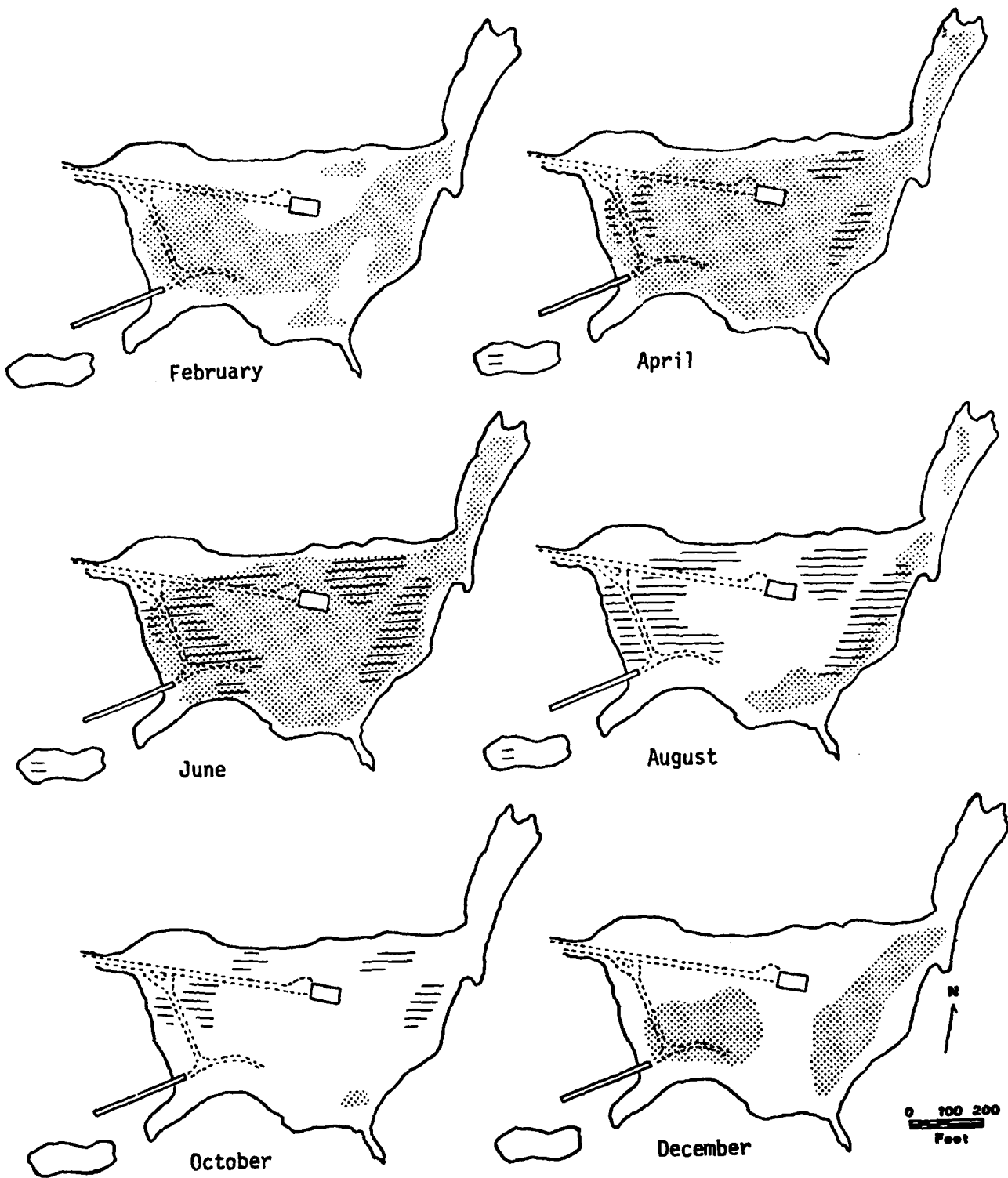

FIGURE 11. AREAS USED BY SOOTY TERNS (STIPPLED) AND WEDGE-TAILED SHEARWATERS (BARRED) ON SAND ISLAND, JOHNSTON ATOLL, 1965

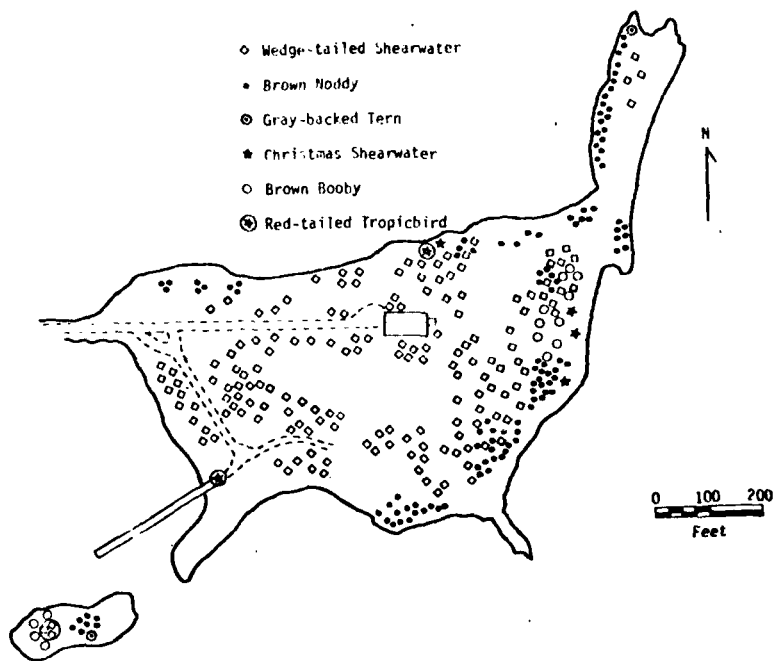

FIGURE 12. NESTING AREAS OF GROUND NESTING BIRDS (EXCEPT SCOTTY TERMS) ON THE ORIGINAL PORTION OF SAND ISLAND, JOHNSTON ATOLL, 1963

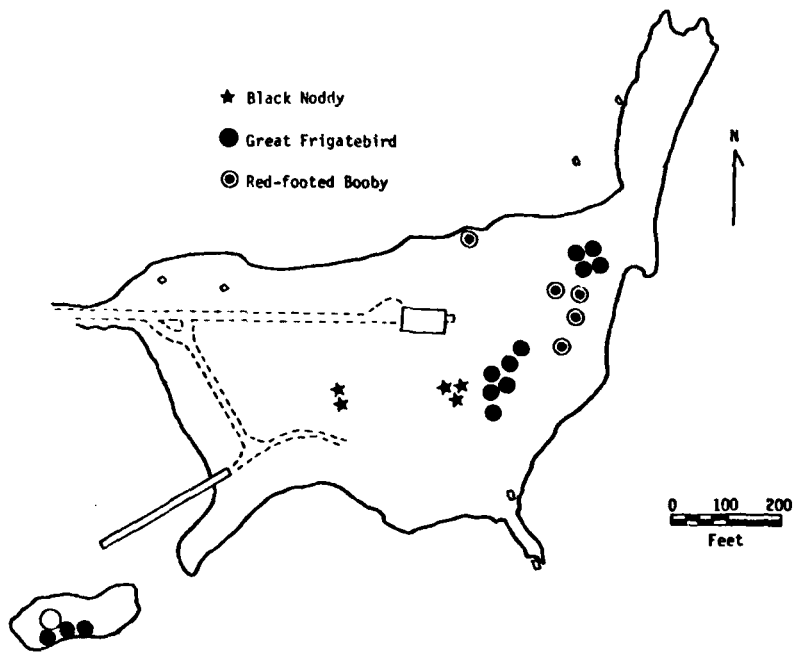

FIGURE 13. NESTING AREAS OF BIRDS WHICH NORMALLY NEST IN LOW VEGETATION ON THE ORIGINAL PORTION OF SAND ISLAND, JOHNSTON ATOLL, 1963

Mortality in the bird population of Sand Island has been studied. The main cause of mortality was birds flying into the guywire system of the LORAN-C antenna. This system contained 24 top-loaded guywires which stretched from the top of the 625 foot tower to concrete pillars located in the lagoon in a circle around the island. There also were three sets of guywires stretched from part way up the tower to two sets of concrete anchors located on or near the periphery of the island.

d. Mammals

There are no mammals native to Johnston Atoll. With the exception of human occupants, five species of mammals are known from the terrestrial and one species from the marine environment of the Atoll (Table III-19). It is likely that the two rodents arrived in ship or plane cargoes, while dogs, cats, and rabbits were purposely introduced by military and civilian personnel.

2.2.2 Marine Environment

The marine environment of Johnston Atoll has been studied to a considerable extent. It has been heavily disturbed by man during dredging operations associated with the deepening and lengthing of the ship channel and seaplane landing area.

2.2.2.1 Plants

Prior to the dredging operations of 1964 only one marine algal species was known to Johnston Atoll. In 1965, as part of a study of the effects of dredging on the marine environment, 67 species of benthic marine algae were collected from Johnston Atoll. Additional collections in 1966 added 26 more species to the known species list. In all, 93 species of benthic marine algae are known from the waters of Johnston Atoll. Of the

93 species, 12 were found only from the marginal reef, while 33 were found only in the lagoon waters (Table III-20). Of these 33 lagoon species, 11 occurred only in open water, 11 were found only in the inshore area of Johnston Island, and 2 were taken from the inshore area of Sand Island.

2.2.2.2 Invertebrates

The invertebrate fauna of Johnston Atoll is not well known. Several scattered collections have been made but no extensive systematic sampling programs have been conducted.

There are 18 species belonging to 11 genera of Cnidaria (hydras, jellyfish, sea anemones, and corals) which are known to Johnston Atoll (Table III-21). Fifty-eight species of Mollusca have been collected from the Atoll (Table III-22). To date, only 12 species of Annelida belonging to 8 families are known from the lagoon waters. These are listed in Table III-23. A total of 75 species belonging to 20 families of Crustacea have been recorded from the lagoon waters at Johnston Atoll (Table III-24).

2.2.2.3 Vertebrates

The marine vertebrates of Johnston Atoll are well known. Fish species have been studied most extensively and are separated into two categories: pelagic fishes and inshore fishes.

a. Fish

Numerous large pelagic fishes have been recorded around Johnston Atoll. Although no extensive species list exists for this area, various species of tuna, sharks, and barracuda are known to occur in the waters around the Atoll.

To date, a total of 194 species of inshore fishes have been recorded from the waters of Johnston Atoll (Table III-25). A majority of these species have also been found in the fish fauna of the Hawaiian

Islands. Only two of the 197 species have not been recorded elsewhere. These are Centropyge nigriocellus and Centropyge flammeus, neither of which is abundant at Johnston Atoll.

b. Mammals

The Hawaiian Monk Seal is the only mammal recorded from the marine environment of Johnston Atoll. These are known to have arrived from the resident population of the northwestern Hawaiian Islands. It is also likely that porpoises visit the Atoll's lagoon waters, although an official record has not been made.

2.3 Human Environment

2.3.1 Economic and Social

There is no indigenous population on Johnston Atoll. Rather, the population is transient representing 4 agencies; namely

- (1) The Air Force, who administer the island.
- (2) The Army, whose "Red Hats" guard and maintain a munitions storage area.
- (3) The Coast Guard, who maintains the LORAN equipment on Sand Island.
- (4) Holmes and Narver, Inc., staff, who perform island maintenance, food, laundry, medical etc. services.

There is not a local economy, all goods and services being provided by these agencies.

The island personnel live in a cooperative atmosphere with very little violence or crime. People who do not abide by the established standards of behavior are rapidly and permanently transferred from the island.

3. DESCRIPTION OF ORANGE HERBICIDE DISPOSAL PROGRAM

3.1 Purpose

Following the decision by the Secretaries of HEW, Agriculture, and Interior in 1970 to suspend some uses of 2,4,5-T, the Air Force conducted an environmental impact study to determine the most ecologically sound method to dispose of the 2.4 million gallons of Orange Herbicide stored on Johnston Island and at the Naval Construction Battalion Center, Gulfport, Mississippi. The approved alternative for accomplishing this objective was the dedrumming of the herbicide at Gulfport and on Johnston Island and the transferal of the TCDD-contaminated material to the Dutch-owned incinerator ship, M/V Vulcanus, for thermal destruction. The operational plan and subsequent activities discussed in this report represent the Air Force's efforts to implement the recommendations contained in the final environmental statement, and to comply with the provisions of EPA permits. (16)

3.2 Operational Procedures

3.2.1 Physical Manipulations

Physical manipulations as discussed include only those portions of the overall operation plan which specifically had implications for causing environmental degradation of the island or its immediate offshore area.

3.2.1.1 Drum Handling-Dedrumming

The 1.5 million gallons of Orange Herbicide stored on Johnston Island represented approximately 25,000 drums of 55-gallon capacity. These were stored in rows stacked three high in an area of about 3.5 acres on the northwest corner

of the island. A dedrum facility was modified* to allow transfer of the material from drums to bulk carriers for transport to the ship. The facility and operation basically consisted of a covered concrete pad and two fabricated metal racks upon which full drums were placed in four groups for 12 each. Drums were transported from the drum yard in sets of four using fork lifts equipped with specially designed clamps. Each set of 12 drums was handled independently by the dedrumming crew. Once the drums were on the rack and the fork lift had withdrawn, a crew member would punch one hole near the top of each drum to allow the crew's supervisory personnel to check the contents of the drum for Orange Herbicide.** Any suspicious looking drums were removed from the line and held for further testing prior to loading. Three closely spaced holes were then punched in the bottom of each drum and the fluid allowed to drain. A set drain period of 5 minutes was determined in prior testing to give the most rapid throughput of drums and still achieve good drainage.

Following the 5-minute drain, the inside of each of the drums was rinsed with 1 gallon of diesel fuel using a spray wand. Operators were instructed on the proper technique to cover the entire drum interior. After draining for 2 minutes, a second one-gallon spray rinse was initiated and 2 minutes allowed for draining herbicide and rinse drained into a trough which flowed into a sump equipped with pumps to transfer the material to a tank truck.

Quality control procedures were carried on through the entire operation. In addition to the testing of contents mentioned previously, samples of the second rinseate were obtained from about every hundredth drum. A total of 219 such samples were taken. A target value of the sum of the concentrations of 2,4-D and 2,4,5-T was derived from test rinses conducted by the Air Force at the Naval Construction Battalion Center, Gulfport,

* The facility had originally been installed for redrumming of leaking drums.

** Drums containing material other than HO were taken off the rack and sealed for future disposal action. Only HO was allowed to drain. As the EIS and permits were only for the destruction of HO, other chemicals could not be allowed to mix with the HO in the sump. Each barrel was examined by pipetting a sample prior to drainage. Visual and olfactory examinations were used to verify contents as being HO.

Mississippi. The level of rinse achieved was to be equivalent to the Environmental Protection Agency triple rinse procedure.⁽¹⁶⁾ Recommendations on the Johnston Island drum rinse procedure were made by Battelle-Columbus Laboratories based on the results of these studies:

- Five spray rinse studies showed that the first rinse efficiency averaged 68 percent removal (range from 64 to 74 percent) while second rinses averaged 69 percent removal (range from 62 to 79 percent). As an approximation, the first and second rinses yielded the same efficiency of 68 percent removal.
- Thirty-five drainage studies showed that, on the average, total mass of 2,4-D and 2,4,5-T remaining in a drum after being allowed to drain for 5 minutes is 261.29 grams with a standard deviation of 139.73 grams.
- The herbicide mass removed in the second rinse was shown to be proportional to the first rinse residual. Increased draintime decreases residual and, hence, second rinse herbicide mass. Increased wash efficiencies on the first rinse also cause a decrease in the second rinse mass.
- Using 68 percent rinse efficiency, and the distribution of residuals from the drainage studies, it can be shown that 50.6 grams of herbicide in the second rinse represents 85 percent removal with 99 percent confidence bounds. Likewise, 46.1 grams represents 90 percent removal.
- Assuming the rinse volumes are exactly 1 gallon (3.785 liters), the sum of the concentrations of 2,4-D and 2,4,5-T for 85 and 90 percent removals (99 percent confidence) are, respectively, 13.36 mg/ml and 12.18 mg/ml in the second rinse. Nominal values will be at 56.4 grams or 14.9 mg/ml (for population mean, nominal 90 percent removal). Because of the overlap, a 68 percent confidence bound was suggested. Accordingly, the 85 percent removal for these upper and lower bounds requires maximum second rinse concentration of 15.30 mg/ml (Figure 14).

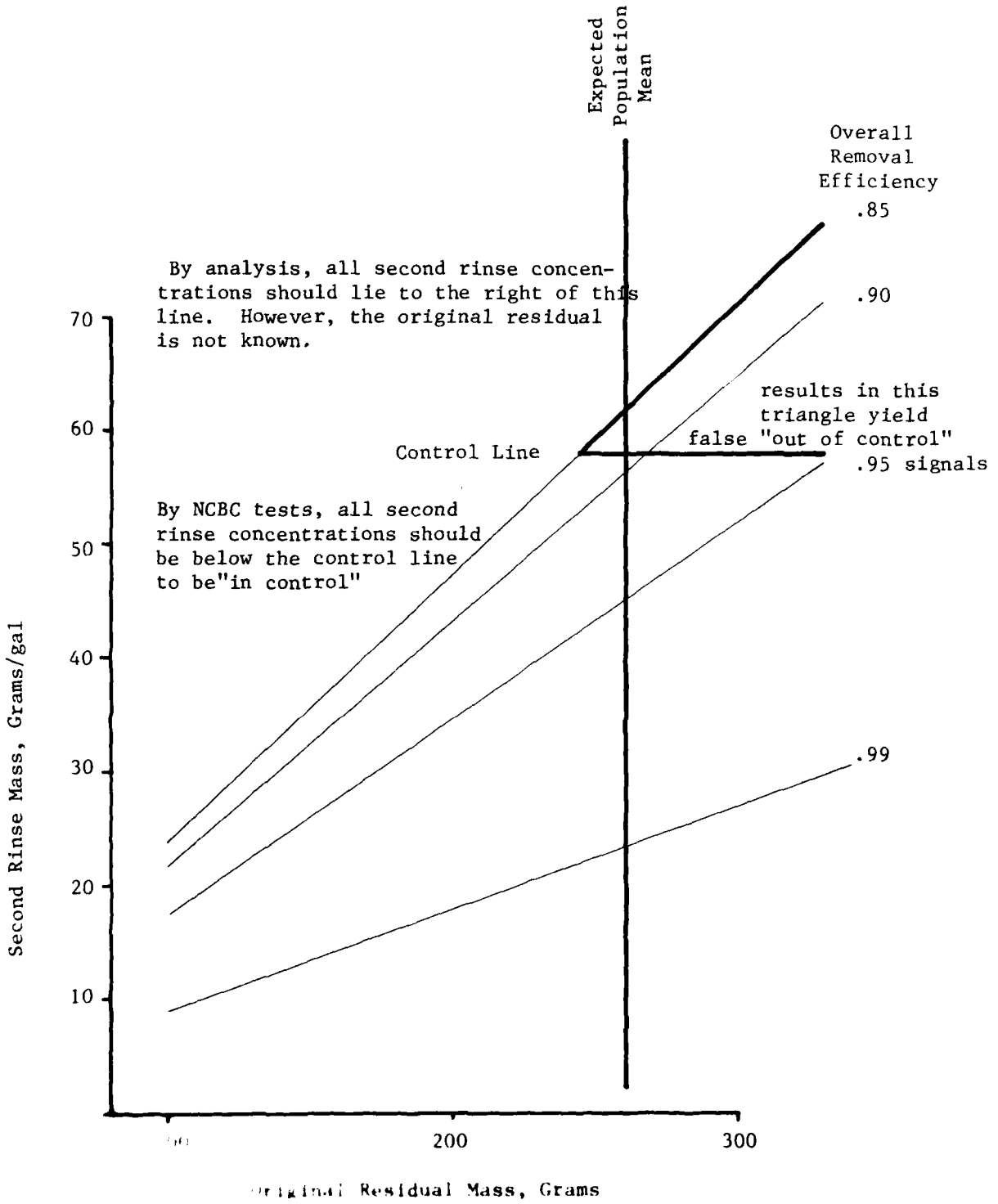

RELATIONSHIP OF SECOND DRUM RINSE MASS

- Because of randomness in the original residual mass, the proposed quality control line is only one-half standard deviation from the expected value for the residual mass of any given drum. Thus, 34 percent of the individual sample results will appear to be out-of-control if plotted. Accordingly, a more accurate trend line can be constructed if only the average concentration of every five samples and the total running averages are plotted.

Figure 15 shows the results of the drum rinsing for all data obtained. Occasionally a series of samples would show a very high average and move the running average up toward the control line. This problem was encountered early in the program and again during the second loading operation. The operation was analyzed following the first loading to determine why the quality control program showed this behavior.

During the first half of Operation Pacer HO, 121 drum rinse samples were analyzed. The overall average concentration for these samples was 17.33 mg/ml of second rinse or .65.5 g/gal. To have achieved the required control level, the concentrations should not have exceeded 14.90 mg/ml.

It was noted during Battelle's observation of the dedrum operation that the pipet used to obtain drum rinse samples was often placed in close proximity to the pipet used to check the drums for suspicious material, inviting a mix-up. The effect that this would have on the rinse quality control would be to have one sample be very high and successive samples be diluted in proportion to the original contamination and the actual rinse efficiency. Other possible reasons for the extremely high values observed, none of which have any bearing on the actual rinse efficiency achieved, are an unrepresentative sample of drum rinse or an accidental first rinse sample. The first is caused by a delay in taking the sample and results in a sample which has separated into its component phases. Since the HO is much more dense than either water or diesel fuel, a sample obtained from the bottom of the container would have exhibited a much higher concentration of herbicide than a well mixed sample. The second, although not directly observed, could easily have occurred during an operation of this nature.

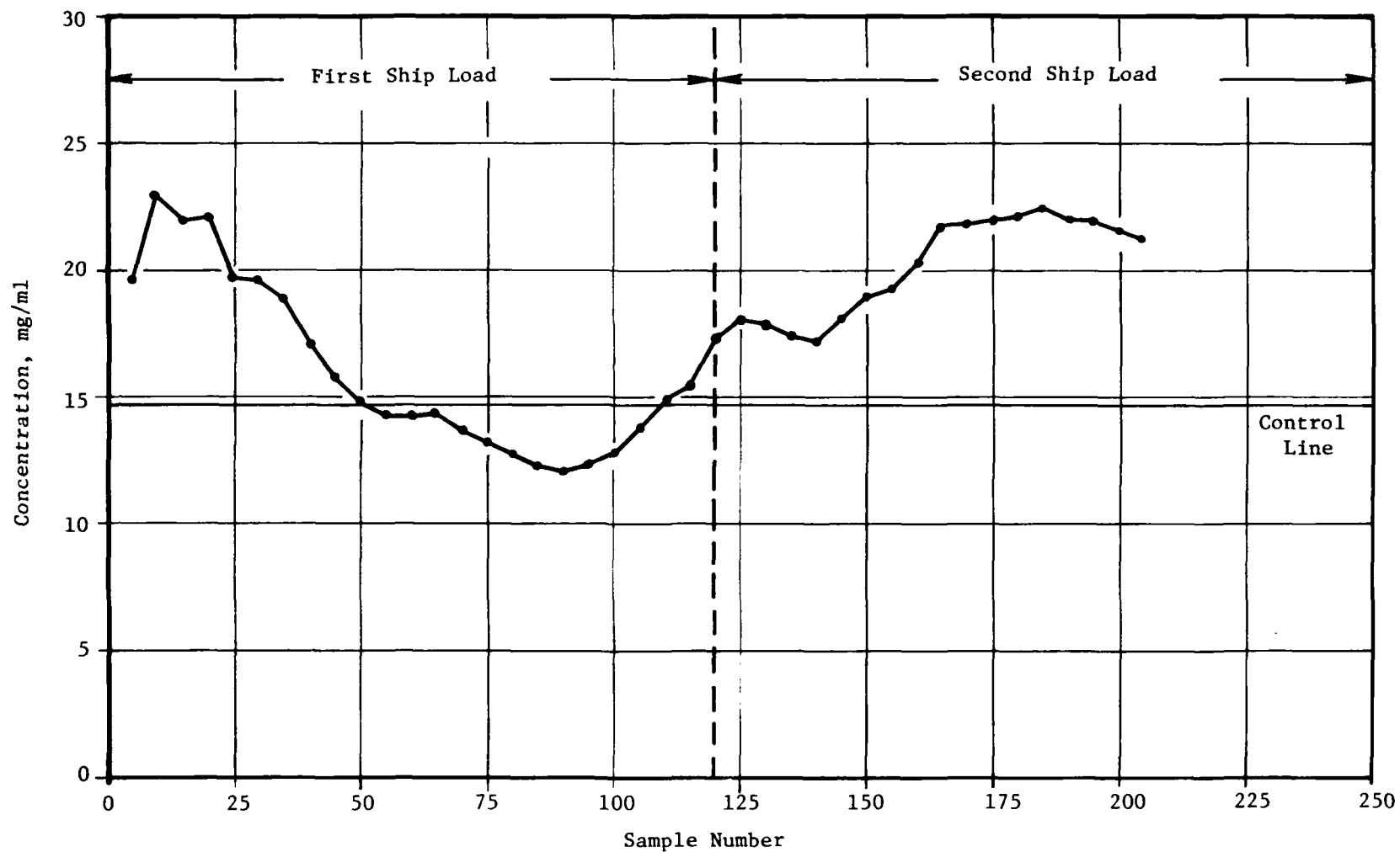

FIGURE 15. DRUM RINSE--QUALITY CONTROL CHART, RUNNING AVERAGES (ALL DATA)*

* Assuming N.D. (<1 mg/ml) = 1.0 mg/ml

Since it could not be determined which of the samples was affected, a statistical review of the rinse procedure was used to determine an upper bound for contaminated or otherwise biased samples.

At a nominal residual of 261 grams and a 69 percent efficiency for the first and second rinses, the concentration in the first rinse would be 47.57 mg/ml and in the second 14.77 mg/ml. Furthermore, for the standard deviation of 139 grams, one percent of the drums would be expected to show as much as 678 grams of residual. With "worst case" assumptions of a 64 percent first rinse and 79 percent second rinse, the expected second rinse concentration for one percent of the population is 50.94 mg/ml.

It was expected that, on the basis of the statistics, one percent of the drums sampled would have shown a true second rinse concentration of greater than 60 mg/ml. These could not legitimately be rejected as outliers. At the same time, the nominal first rinse concentration was about 48 mg/ml. If an accidental first rinse sample were included, its concentration would have been about the same as the "worst case" residual described above. A first rinse sample should be rejected. A compromise between the errors involved in including a first rinse sample as an estimator of second rinse efficiency and of rejecting a true second rinse which falls on the "tail" of the sampling distribution was needed. It seemed reasonable, therefore, to reject as outliers all samples showing second rinse concentrations in excess of 47.0 mg/ml. A total of nine samples were rejected during the first loading period and 14 during the second loading period. The resulting running averages are shown in Figure 16 and are seen to comply with control conditions.

Suggested improvements to the drum rinse quality control program were as follows:

- Control of the drum rinse sampling pipet should be by the person who counts drums. He should also be responsible for selecting the drum to be sampled so as to assure that one station is not biasing the sample.
- As the drum is sampled, he or another man should make sure that a second rinse sample is being taken and not a first rinse. It may be that in the confusion of the operation mistakes are being made.

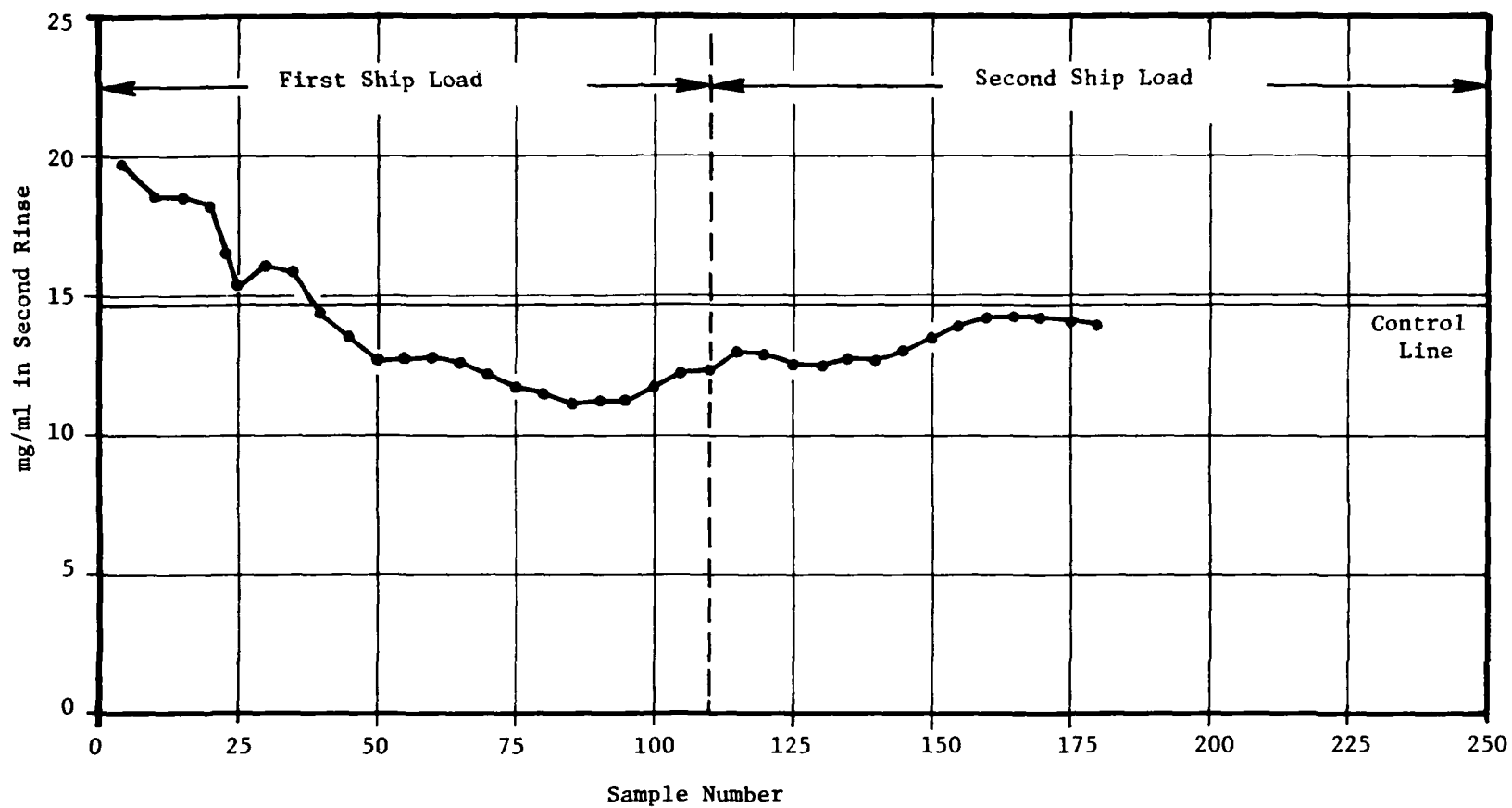

FIGURE 16. DRUM RINSE--QUALITY CONTROL CHART, RUNNING AVERAGES
(47 mg/ml cutoff on high end = 179 g/gal)

- The sample container should be stirred with the pipet before sampling to obtain a more homogeneous sample.
- The pipet should be specially marked with paint or other easily seen and indelible marker.
- The location of the sampling pipet should also be marked to avoid cross contamination with drum-test pipets. These should not be kept near the sample pipet.
- The sample should be drawn using the index finger rather than the thumb. This will maintain better control and permit faster sampling, thus, minimizing the possibility of inhomogeneity.
- The drum selected for the rinse sample should have only one drain hole punched in it. This facilitates the capture of the rinse in the gallon can.
- The drum counter is also responsible for assuring that the drum drains for exactly 5 minutes prior to the first rinse.

A second category of special drum rinse samples consisting of a set of four run in duplicate was used to verify that the concentrations of HO in 3,300 previously emptied drums was below the control line using only a single rinse. The material in these drums had been subjected to weathering for a period of from two weeks to over six years. The mean concentration using one gallon rinse was 3.56 mg/ml (13.5 g/gal) with a standard deviation of 3.21. Thus, there is negligible probability that the observed values do not meet the EPA triple rinse criterion. The Air Force's decision was to forego further quality control testing on the remaining emptied and weathered drums and to provide a single one gallon rinse to these drums.

After the second rinse had been allowed to drain for two minutes, the drums were removed from the racks by rolling them the northwest corner of the dedrum facility. Fork lifts with a ramp attached to the forks were used to transport the empty drums to the crusher.

3.2.1.2 Drum Crushing

The fork lifts transported six drums per trip to the crusher feed ramp. Drums were fed to the crusher one at a time. The crusher consisted of a large weight suspended between two I-beams. The drums were compressed along the longitudinal axis. There were no spray shields around the crusher to trap the mist of oils and residual HO which was released on impact (Plate 3). Several times the crushing operation fell behind the dedrumming operation and the empty drums were stacked up on the ground around the crusher.

Crushed drums were bundled and placed in storage on the seaward (downwind) side of the dedrum/crushing area. A large plastic sheet was used to protect the crushed drums from rain.

3.2.1.3 Transport of HO to Disposal Ship

Herbicide was pumped from the collection sump into standard Air Force R-5* refueling trucks (Plate 4) via a dry coupler bottom connection. Because of the difference in density between the HO and JP-4, the R-5's were only filled with 3,000 gallons of HO versus a 5,000 gallon capacity. During the filling operation, a drip pan under the coupler was used to prevent any herbicide from contaminating the loading pad. When disconnection took place, a few drops at most were observed to be discharged into the pan.

The refuelers transported the HO to the wharf via a road which was set aside for this purpose. Non-project related vehicles were forbidden traffic along this section of roadway.

3.2.1.4 Transfer to Disposal Ship

Once the refueler had reached the main wharf, the procedure was essentially reversed. The same type of dry couplings and spill prevention equipment were employed to pump out the tank and bulk transfer the material

* The pumps on the R-5 were bypassed to prevent their contamination and seal destruction by HO.

to the ship. The area in which the pumps and hoses were located was diked with sand bags and plastic so that as much as a full truck load of spilled material could be contained (Plate 5). All hose-to-hose couplings were similarly wrapped in plastic to catch any herbicide.

Under normal conditions, an R-5 could be emptied in about 20 minutes with another arriving to replace it just about the time it became empty. The only problems noted in this operation were the clogging of screens used to trap sludge particles, and the formation of a flow retarding vortex in the R-5's.

3.2.1.5 Cleanup

After the last HO had been transferred, all of the equipment, trucks, etc., were rinsed and decontaminated with diesel fuel which in turn was transferred to the ship.

3.2.2 Descriptions of Project Activities

This section provides, in outline form, all environmentally relevant project related activities contained in the official memos for the record or in BCL project records.

- July 23-- All personnel involved in the project were briefed by the Project Director on matters of spill prevention, countermeasures in case of spills and personal safety. Contingency equipment was inspected and positioned.
- July 23-24--BCL task leaders held discussions with corresponding Air Force officers regarding placement and start-up of land-based environmental monitoring (see Section 3.2.3).
- July 24--First day of baseline environmental monitoring.
- July 25--M/V Vulcanus arrived at approximately 1500 hours.
- July 26--Training operations for drum crew began at 1300 hours. Three drums were taken through procedure on day shift and three on night shift.
- July 27--Full-scale loading operations commenced at approximately 1500 hours. Several small leaks in R-5 were noted and corrected.

One badly leaking drum was located and removed to the dedrum rack. Clean-up was instituted. An estimated 25-30 gallons were spilled onto the coral storage area.

- July 28--A very small (<1 gallon) spill on the wharf was noted. No water contamination was observed and spill clean-up was accomplished.
- July 30-- During deballasting, an orange colored plume was observed on the port side of the M/V Vulcanus from 1100 hours to 1800 hours. Black oily trailings were visible in several places. Samples were taken at 1100 hours near the discharge of the deballast pump at a depth of 1 meter below the surface.
- July 31--Air Force was informed of preliminary air and water sampling results.
- August 1--The Air Force was advised on the trend of the drum rinse quality control results up toward the control line. Results of previous day's deballast water sample submitted to Air Force.
- August 2--EPA decision to require one tank filled with pure herbicide will result in 600-650 empty drums that have not been rinsed being temporarily stored near the dedrum facility. It was recommended that plastic be spread on the ground to prevent any spillage. Dedrumming resumed at 1900 hours after 24-hour hiatus.
- August 4--Drum rinse sampling procedure changed to obtain samples from all stations uniformly. Personal samples from pump operator inside dedrum facility eliminated because of low concentrations measured.
- August 5--Dedrumming completed 2100 hours. Land-based monitoring schedule for interim period submitted to TRCO. Improved procedures for sampling of drum rinse were suggested by BCL and accepted by the Air Force.

- August 6--M/V Vulcanus departed 0830 hours. Dedrum crew began rinsing and crushing 648 drums from temporary storage.
- August 11--All drums have been rinsed and crushed. Lab work load adjustments discussed with TRCO to permit analysis of wipe samples from ship at close of program.
- August 15--Results of first load lab analyses submitted by BCL to Air Force. Drum rinse quality control program improvements were brought up again. In the course of conducting tomato plant bio-assay studies, it was found that the plants uniformly were wilting due to the extreme evapotranspiration. The problem occurred because the pots, as provided, were too small and the peat potting medium lacked the necessary water holding capacity.
- August 16--Suitable volcanic mineral soil was added to the potting medium. The surface of the soil was covered with aluminum sheets to reduce evaporation. The plant wilting was eliminated. The previously damaged plants were replaced.
- August 17--All air, water, and biological observation schedules were reinstated. Drum rinse sampling monitoring was initiated preparatory to the second burn. Tomato plants downwind of the dedrumming facility continued to be affected by the herbicide. It was suspected that the vaporization of the HO from rows of crushed drums compounded this phenomenon. The bed of the truck used to haul tomato plants and equipment was found to be contaminated with HO. The bed was replaced immediately with clean materials. The loading of M/V Vulcanus began at 1300 hours. Continual spill reconnaissance was initiated.
- August 18--The industrial hygiene consultant notified the Air Force that some civilians were smoking adjacent to loaded R-5 refuelers. The operations officers were notified that no smoking materials or food should be taken into the dedrumming facility. Appropriate actions were taken to prevent future occurrences.

- August 19--A brownish plume was observed and photographed, as the M/V Vulcanus was pumping ballast while berthed at the wharf. A grab water sample was taken near the stern of the ship. Dedrumming and ship loading was suspended at 0600 hours. No marine ecology impacts were observed. Fish were noted swimming in the area of the deballast plume. The potable water intake was closed during the deballasting operations.
- August 20--Slight water discoloration still existed between the M/V Vulcanus and the wharf.
- August 21--Battell's analytical laboratory reported that the deballast sample results had several peaks and without further dilution studies, they reported that they could not state the levels of 2,4,5-T or 2,4-D in the grab sample. Dilution studies and a rerun of the sample was requested.
- August 22--Deballast results were submitted to the Air Force.
- August 24--A ground water sample taken from a bore hole in the barrel yard storage area smelled strongly of herbicide orange. It was highly probable, due to the lack of a berm, that the surface contamination entered the bore hole or observation well. The post-operational monitoring program was begun.
- August 27--Numerous bird species were observed and surveyed on Akau, Hikina, and Sand Islands of the Johnston Atoll. (All were in apparent good health except birds with broken wings that had flown into antenna guywires.) Abundance and type of fish species were noted in the wharf area. No marine ecological stress was evident.
- August 28--Plant species on Johnston Island were surveyed. There was no evidence of native plants being affected by the Orange Herbicide disposal operations. This was the last day of post-operations monitoring.

3.2.3 Physical Monitoring Sampling Protocol

3.2.3.1 Chemical Sampling

a. Air

(1) Equipment and Procedures. In order to assess the impact on the air environment due to the possible presence of the N-butyl esters of 2,4-D and 2,4,5-T and the dioxin, TCDD, two methods were employed.

Air sampling for 2,4-D and 2,4,5-T was accomplished utilizing Chromosorb 102 as an adsorption medium, a granular polymer well suited for collection of chlorinated hydrocarbons. This material was packed in micropipet tubes which were then wrapped in aluminum foil and stored in rubber stoppered test tubes (Plate 6). In order to sample a volume of air of about 150 liters, a flow rate of 0.50 liters/minute for a period of about five hours was required. A good adsorption efficiency could be obtained at this flow rate. A five hour sampling time was adopted which corresponded to the length of one-half shift. This sampling procedure for the operations area avoided interruptions when the shifts were breaking for meals.

The sampling apparatus consisted of an MSA Model G Personnel Sampling Pump mounted on top of an upright clean 55 gallon barrel for all ambient stations. The chromosorb tubes were connected to the pumps with Tygon tubing or, for the samplers worn by workmen where greater flexibility was desirable, latex rubber. In order to minimize the likelihood of rainwater contamination, the tubes were attached so that the opening to the tube would face downward.

The pumps at the ambient stations were maintained on constant "high" recharge throughout the period, regardless of whether or not the pump was in use. The pumps worn by workmen were battery powered for the five hours. These pumps were then recharged in one of the sample-preparation rooms in Building 190 during the next half-shift.

Flow rates were checked at hourly intervals with a rotameter and adjusted to ensure that the 0.50 liter/minute flow was being maintained. In only a few instances did the pumps fail to maintain the desired flow.

Air sampling for TCDD was accomplished utilizing benzene as the absorption medium. The apparatus consisted of a train of four impinger columns, the first two filled with 350 and 250 ml of benzene, respectively, and the final two with activated carbon (Plate 7). Activated carbon was used to adsorb the vaporized benzene from air flow through the first two columns. The benzene columns were wrapped with aluminum foil to avoid photo-decomposition of the TCDD in the sample. Following the carbon columns, a paper filter was attached with Tygon tubing to prevent any carbon from entering the pump.

The pumps were operated directly off the 110-volt AC lines located at the sampling stations. The entire impinger train with pump was mounted on the same barrels as the MSA pumps at each station. As with the chromosorb apparatus, the flow rate through the impinger was periodically checked using a rotameter and adjusted as necessary at a bleeder valve. A rate of 1.0 liter/minute was chosen; however, this rate may have been in error by as much as 20 percent, as variability in the pumps' speed and the effect of increasing amounts of saturated carbon caused fluctuations in flow.

The established running time of five hours was about the maximum duration for maintaining flow without saturating both columns of carbon, which would result in a benzene breakthrough. About halfway through the study, it was found that the columns were becoming saturated after about 4 hours. As a result, the procedure was modified such that the last column filled with saturated carbon was removed and replaced with a column filled with fresh carbon during the sampling period. This enabled the entire half-shift to be represented as well as to provide a larger sample volume. Reasons for the more rapid adsorption rate are speculative, but it is believed that the carbon used in the second half of the study was of lesser quality

Samples were removed from the sites with the entire impinger trains intact within wooden holders. The benzene was drained into brown glass jars in one of the sample preparation rooms of Building 190 (Figure 3). The glassware was then rinsed once with benzene into the sample containers to collect any portions that may have adhered to the impinger walls. The samples were stored in a dark, cool room in Building 190 before being packed for shipment to the Occupational and Environmental Health Laboratory at Kelley Air Force Base for later TCDD analysis.

Prior to reuse in the field, the impinger glassware had three acetone rinses followed by one rinse with benzene.

(2) Air Sampling Sites. Four areas were sampled for the N-Butyl esters of 2,4-D and 2,4,5-T and TCDD. These were: (a) the dedrumming facility, (b) a position 310 feet west of this facility, (c) the wharf where the M/V Vulcanus was docked, and (d) the weather station. Figures 17, 18 and 19 show the locations of the air sampling sites.

The remaining three areas (b), (c), and (d) were ambient sites. Each station was characterized by an impinger and chromosorb apparatus placed upon clean, 55 gallon drums.

Site (a) Air inside the dedrumming facility was sampled to allow for a comprehensive industrial hygiene report. An impinger was located on a clean barrel at the southwest corner of the shelter for TCDD detection.

In order to obtain workmen's exposure to 2,4-D and 2,4,5-T, persons working inside the facility in close contact with the herbicide were required to wear an MSA pump around the waist with a chromosorb tube attached near the breathing zone. When a workman wearing a sampler would leave the area to take a break, the samplers were turned off preventing such potential contaminants as cigarette smoke from being drawn into the sample. This procedure assured the detected concentrations to be representative of that inside the facility. As a further precaution, most of the chromosorb tube was left wrapped in aluminum foil to minimize contact of the outer portion of the tube with the herbicide, a possible route to

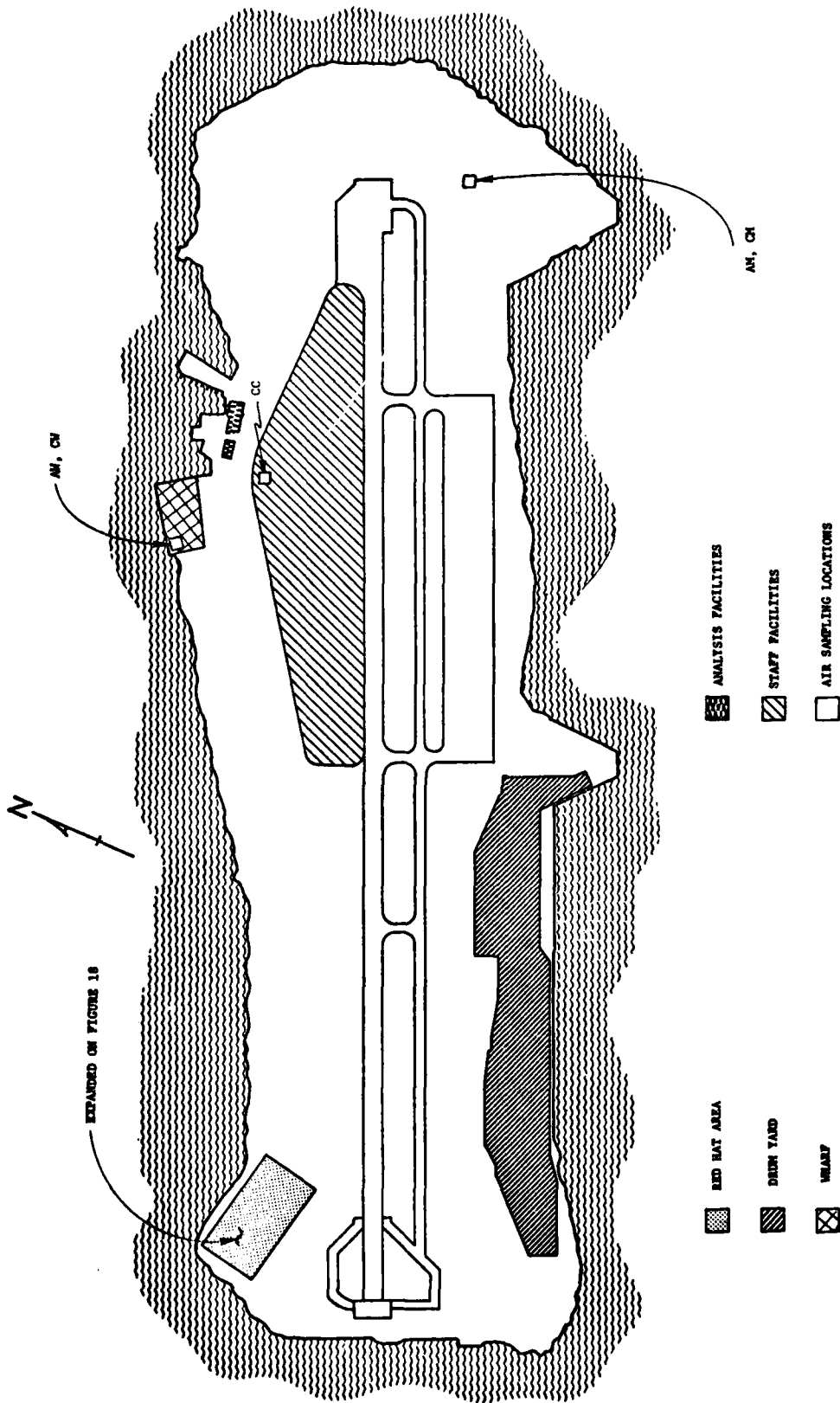
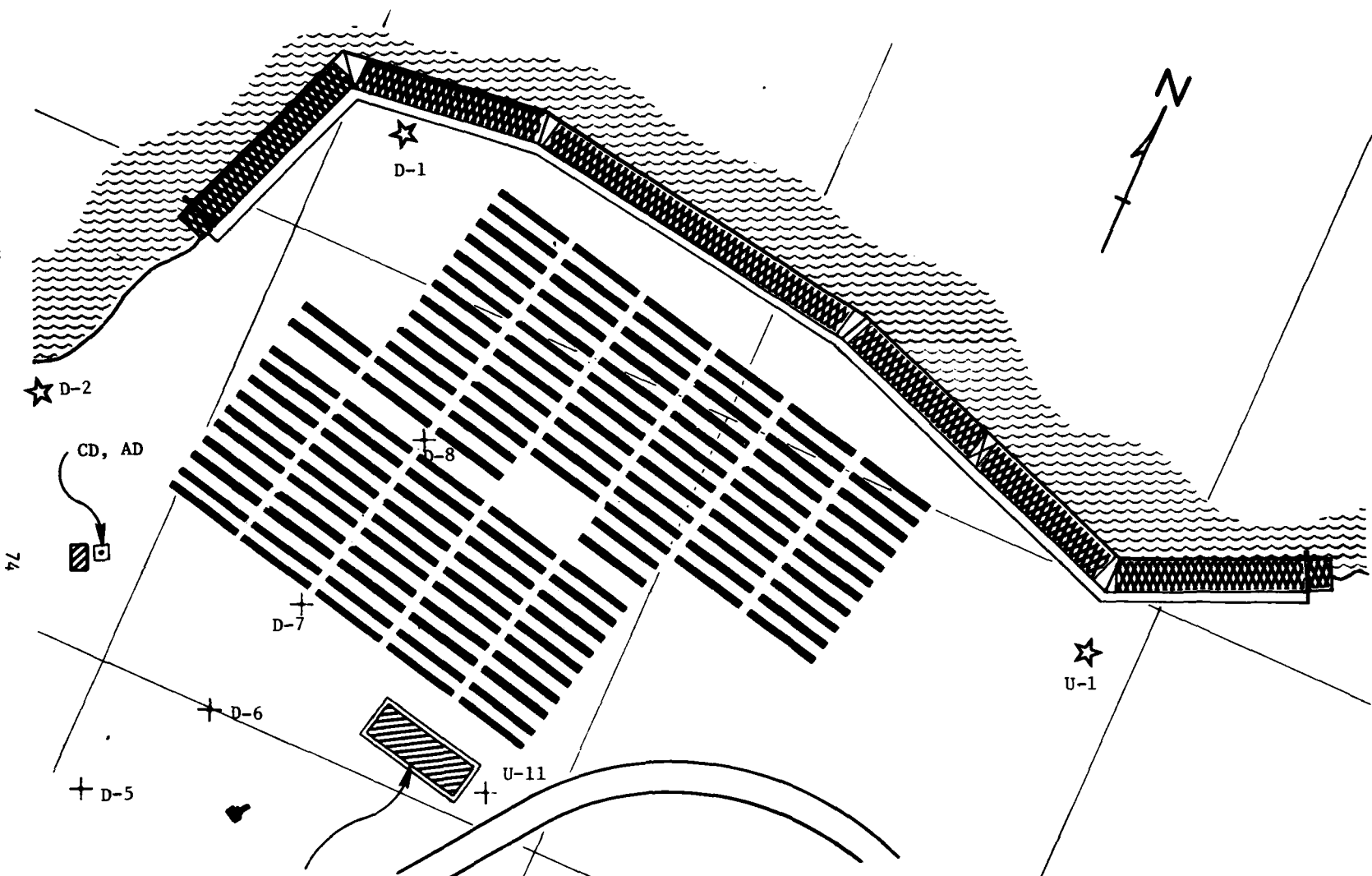

FIGURE 17. AIR SAMPLING SITES



EXPANDED IN
FIGURE 19

- AIR MONITORING SITES
- ★ TOMATO MONITORING SITES
- + SUPPLEMENTAL TOMATO SITES (POSTOP)

FIGURE 18. AIR MONITORING SITES, DRUMYARD

N
A

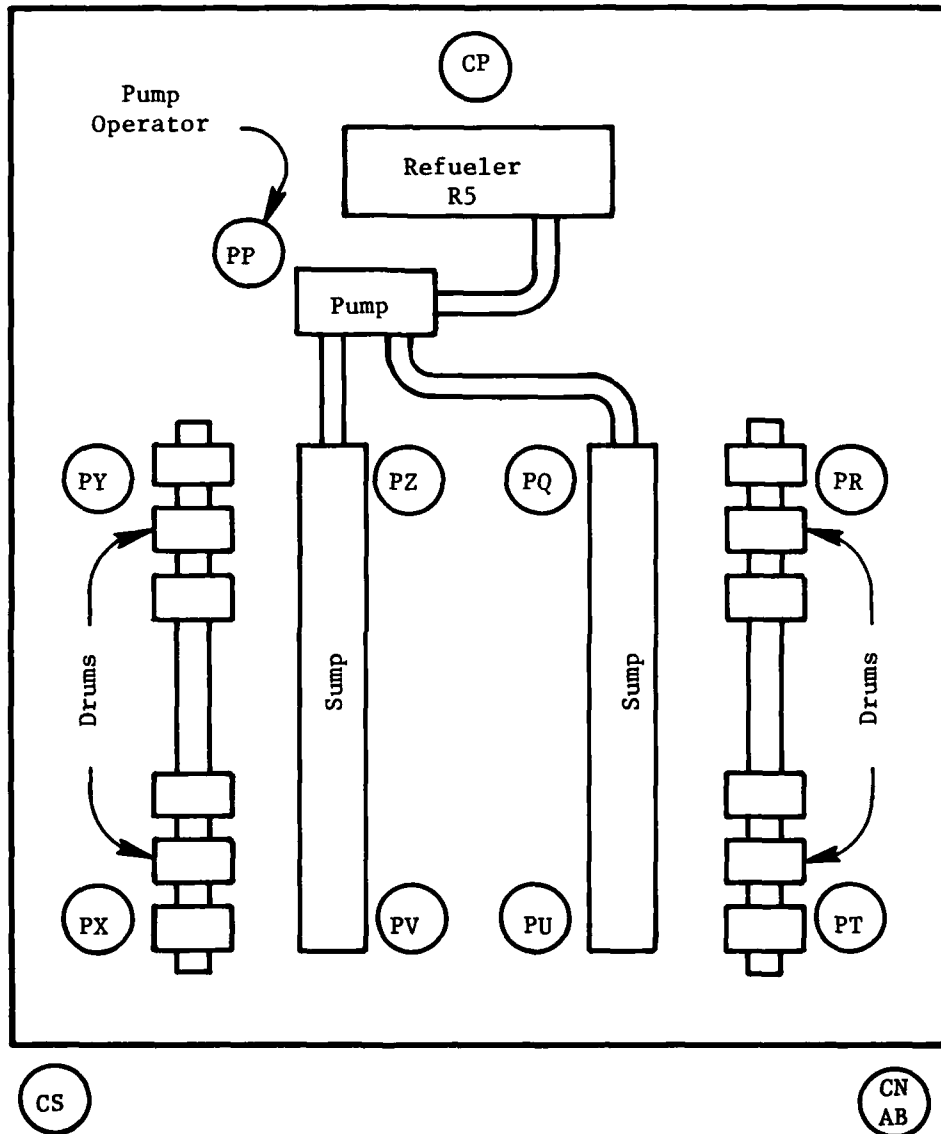

FIGURE 19. SAMPLING SITES AT DEDRUM FACILITY

contamination of the sample. Once the sampling duration was complete, the chromosorb tube was rewrapped in clean foil and submitted to the lab. The tubes were then cut inside the laboratory and the lower contaminated portion of the tube discarded before removal of the Chromosorb 102 granules.

Because the pumps were turned off during breaks and some time was required for the crews to dress and undress during each half shift, the five-hour sampling time could not be achieved. In most instances, however, a sample volume of at least 100 liters was obtained at the 0.50 liter/minute flow rate.

In addition to the impinger and personnel samples, chromosorb samples were taken on occasion at two western (downwind) corners and at the center of the eastern wall of the dedrumming facility. Most of these were taken during inoperative periods, when crews were not dedrumming the herbicide.

Site (b) Located 310 feet west of the dedrum site, the downwind site was chosen to assess the affects of the barrel storage area, dedrumming the herbicide, and other operations on the air environment of this area. A comparison of the ambient levels at this station with observed tomato plant damage was possible due to the proximity of the plants with respect to the site.

The downwind station was located near the crushed drum storage area (to the south), the contaminated wood stockpile (to the southwest), and the wind recording station with anemometer. The effects of the crushed drum storage agea and the wood stockpile on detected concentrations at the downwind station was minimal due to the constance of the wind from perpendicular to opposing directions. The proximity of the anemometer with the station allowed a close correlation with immediate wind directions and speeds.

Site (c) A third air sampling station was established on the wharf at the western most light pole, approximately 300 feet from the truck-to-ship pumping station. Although winds were usually slightly out to sea with respect to this area, the position of the station does allow for an assessment of the ship's presence and pumping operations on the ambient air levels of the land adjacent to the wharf.

Site (d) The fourth site, located at the weather station, was utilized for measuring the air background levels and was far upwind of all operational areas.

(3) Air Sampling Intervals.

(a) Preoperational. Air sampling was conducted for a three-day period (July 24 to July 26) before dedrumming operations commenced for the purpose of establishing baseline for the study. Benzene and chromosorb samples were run daily at the weather station, wharf, and downwind sites. Additionally, three benzene samples (one/day) and three chromosorb samples (all on July 26) were run inside the dedrumming facility. These samples were representative of the late-morning, early-afternoon hours.

(b) Operational. Air sampling during dedrumming and associated operations commenced on July 27 and lasted through August 5 for the first loading of the M/V Vulcanus. The second loading took place over the interval August 17 through August 23. Generally, sampling during operations was limited to the five-hour half-shifts of the morning and evening. From the study performed at Gulfport, it was learned that the time of day had little effect on concentrations detected in the field. Nearly constant climatic conditions support this idea for Johnston Island.

A total of 120 valid chromosorb samples were taken at the four areas of study during the two operational intervals. Their distribution is shown below.

- Weather station - 22
- Wharf - 18
- Downwind station - 26
- Personnel samples - 43
- Corners of dedrum - 11

Only eleven samples were taken at the edges of the dedrumming facility because it was decided that for purposes of sampling exposure in the working area, personnel sampling would be a more representative method. When possible, two separate personnel were monitored each half-shift. Early in the study, a third sample worn by the pump operator at the eastern end of the facility was taken to compare his exposure to that of workmen who were actually opening and draining the barrels.

In addition to the chromosorb samples above, benzene samples were run at the four sampling sites on the same two/day basis.

(c) Interim. Very limited air sampling was performed during the ship's burn of the first loading. On August 6 and 8, the downwind site and weather station site were sampled. On August 11, the wharf and weather sites were sampled, making the total number of samples taken during the interim period six chromosorbs and six benzenes. All of these samples were run during the morning hours.

(d) Post-Operational. Sampling after the ship's departure for the burn of the second loading extended from late afternoon on August 23 through the evening of August 26. The hourly intervals investigated were those of the morning and late afternoon-early evening. Moving the evening sampling up to include part of the afternoon allowed representatives of more daylight hours, thus a more accurate assessment of the effects of radiant energy on the barren, barrel storage area could be made. At the same time, the morning sampling interval was left unchanged for the basis of comparison with operational values.

A total of 32 Chromosorb and 25 benzene samples were taken at the downwind, wharf, weather station, and dedrum sites. Unfortunately, 10 of the chromosorb samples had to be discredited due to unreasonably high 2,4-D to 2,4,5-T ratios. It was found after the submission of three blank chromosorb tubes (in addition to the blanks submitted on August 3, August 11, and August 20) and other tests run in the laboratory that a box of thimbles used for the GC were contaminated. As a result, most of the chromosorb data from the afternoon of August 25 through the end of the study was lost.

The distribution of valid chromosorb data for the post-operational period, therefore, is as follows:

- Weather station - 4
- Wharf - 4
- Downwind station - 5
- Dedrum facility - 9

3.2.3.1 Chemical Sampling

b. Water

The sampling program for the water environment of Johnston Island consisted of four offshore sites and two onshore sites (Figure 20). The offshore sites were located in such a way as to monitor a particular land based HO operation while the onshore sampling points allowed assessment of the incoming herbicide load to the water treatment plant and the outgoing load from the sanitary waste system.

Samples were taken of the water near the main wharf at two points just off the bow of the ship at 10-11 meters of depth (Plate 7). The water current in this area and the density of the herbicide/diesel fuel mixture relative to seawater at 25°C were used to select locations where a spill would be likely to be found (See Section 2.1.3.3). Samples were obtained daily between 0800-0900 hours, 1300-1400 hours, and 1800-1900 hours using a landing craft or outboard motor boat. A set of brown glass jars of 1250 ml capacity, prewashed with acetone, were used for temporary storage. A plexiglass Van-Dorn bottle of 1-liter volume was used to obtain the samples from the water column. Immediately after transferring the sample to the glass jar, measurements of dissolved oxygen and temperature were made with a Yellow Springs Instrument Corporation salinity compensating polarographic unit. Jars were capped to prevent any degradation from sunlight.

The saltwater intake for the desalination plant was sampled daily at about the same times as the wharf samples and at a depth of

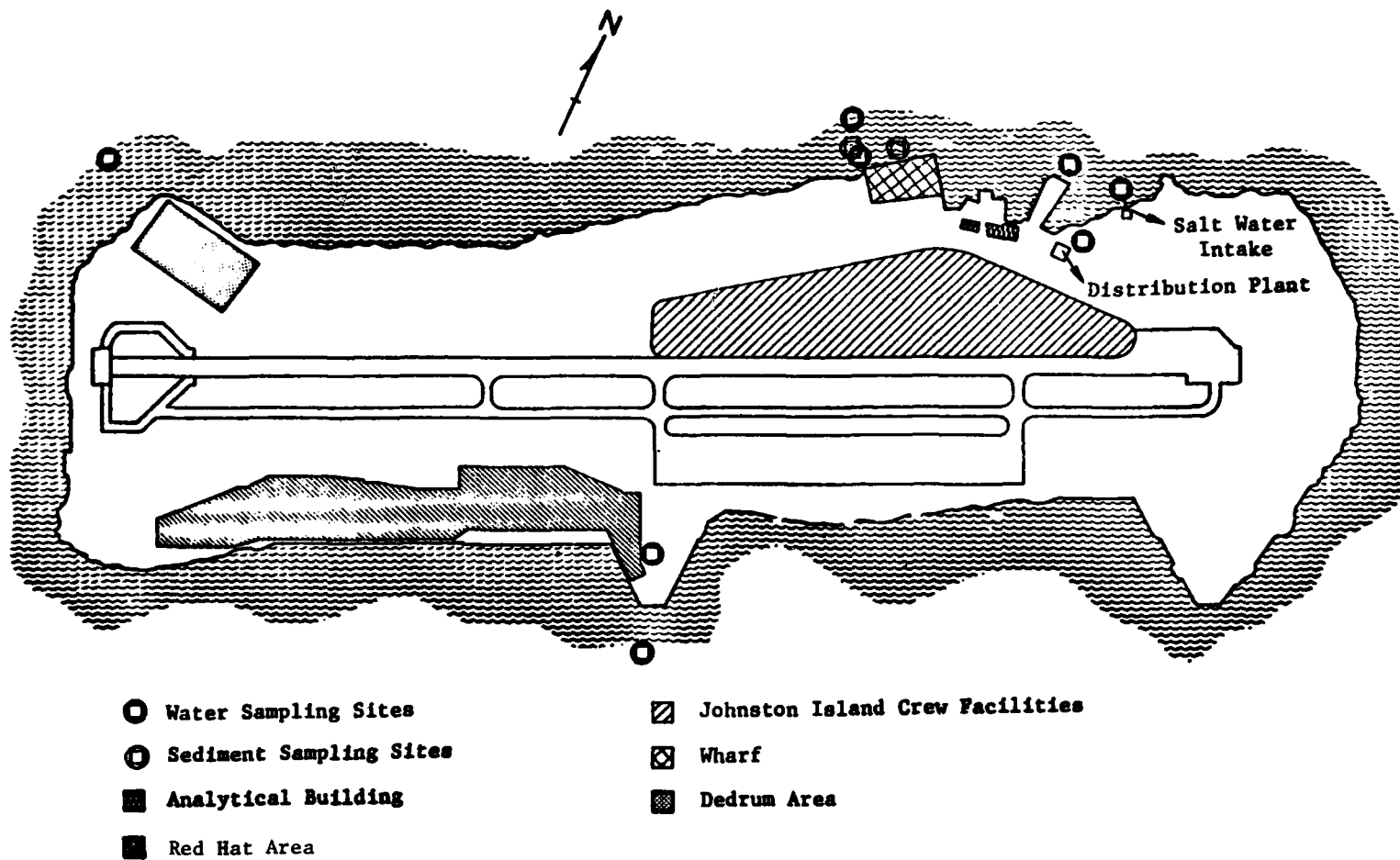

FIGURE 20. WATER AND SEDIMENT SITES

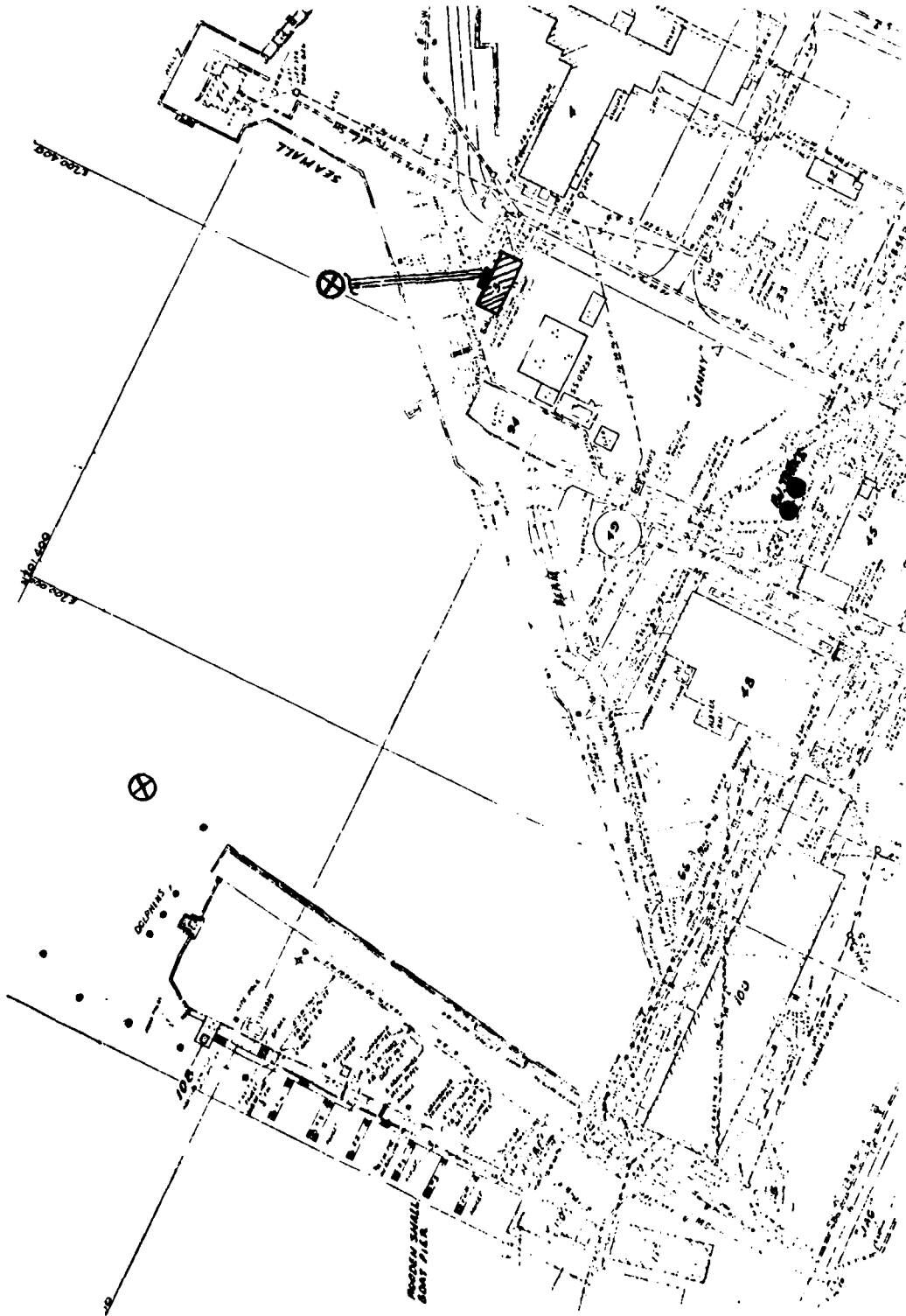

FIGURE 21. SALTWATER INTAKE SAMPLING POINTS

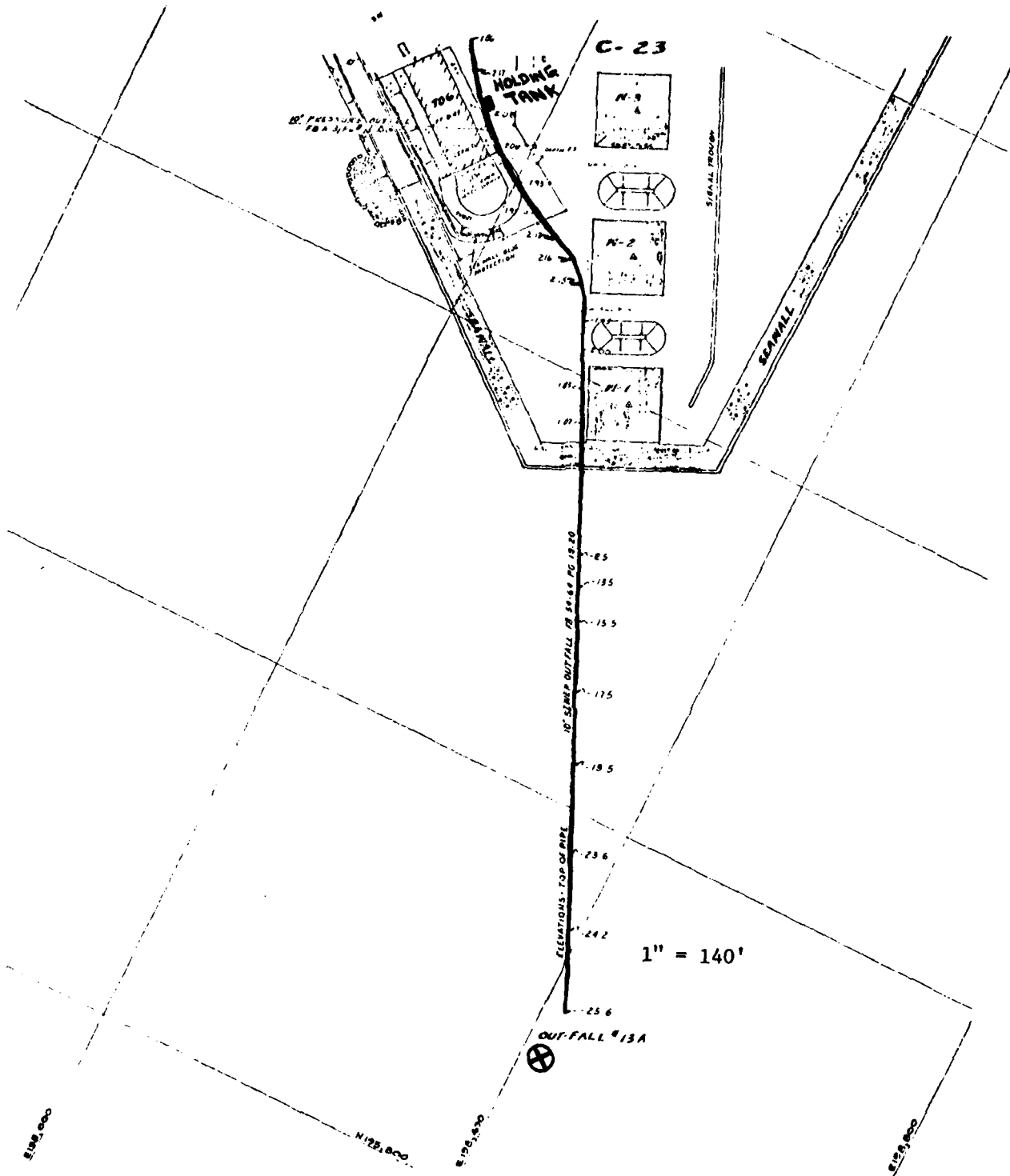

FIGURE 22. LOCATION OF SEWAGE OUTFALL SAMPLING SITE

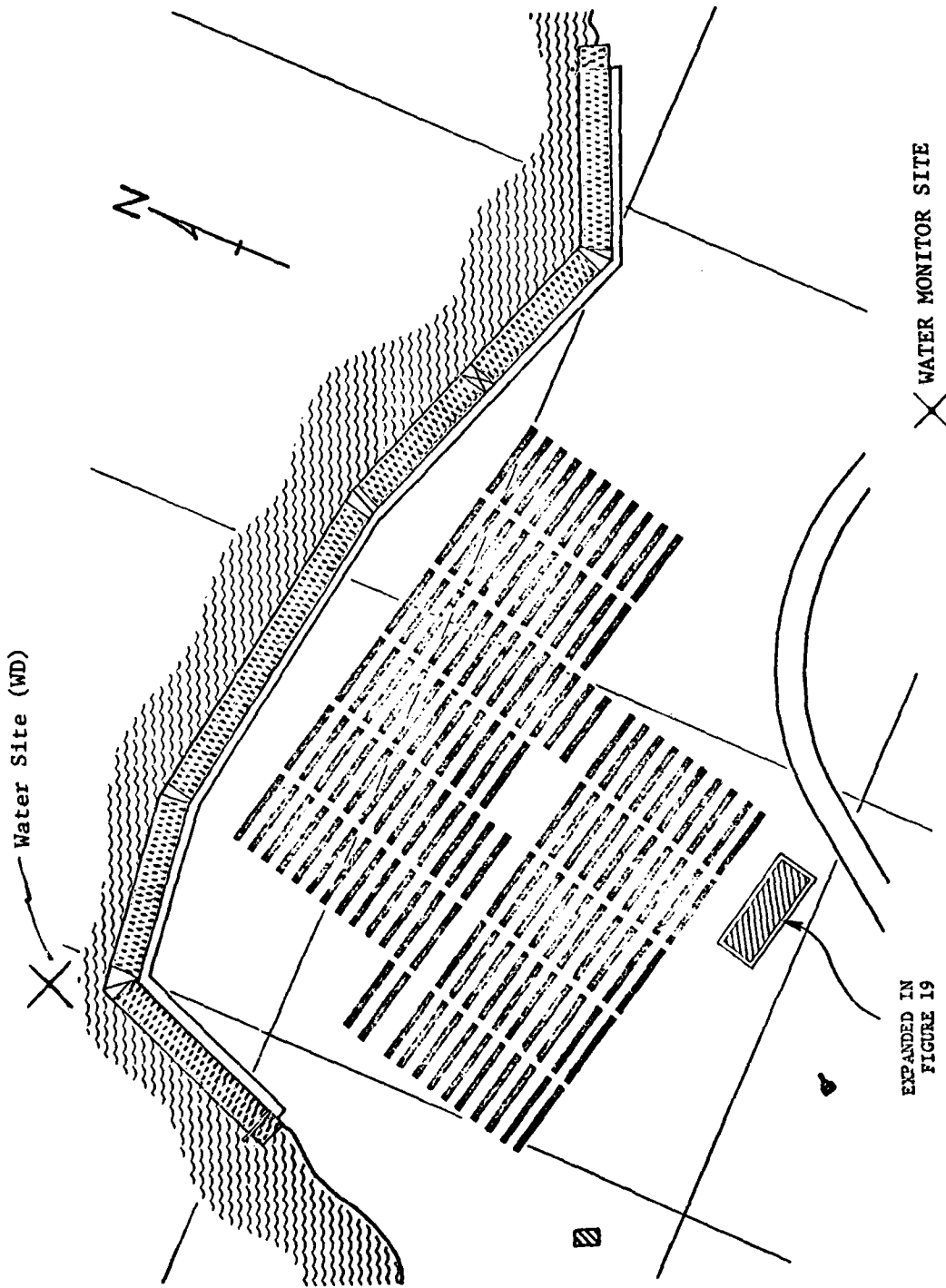

FIGURE 23. WATER MONITORING SITE, DRUMYARD

EXPANDED IN
FIGURE 19

five to six meters (about one meter from the bottom). Two coordinates were sampled--one at a point 5 meters offshore of the small boat piers and on a line from the north corner of the main wharf to the perpendicular drawn from the small boat pier and a second at the intake screen for the system, which consisted of three 24 in. intake pipes (Figure 21).

The third offshore location sampled on a regular basis was the sewage outfall on the south side of the island. Because of the difficulties in reaching this site with anything other than one of the landing craft, it was possible to sample this site only every other day. Samples were taken at a single point approximately 550 feet offshore and slightly down-current of the submerged sewage outfall. Raw sewage could occasionally be smelled in the samples. The sample depth was 6 to 8 meters; the depth to the top of the submarine outfall is 8.3 meters according to engineering blueprints of the waste disposal system (Figure 22). Samples were taken between 0800-0900 and 1300-1400 hours.

The fourth offshore site, sampled four times, was the shallow offshore area near the drum storage yard (Figure 23). Water samples were taken at about 1400 hours once each during the baseline, first loading, second loading, and post-operational periods. During the baseline sampling, water was drawn from 5 meters depth and during the first loading period water from 2 and 8 meters was composited into a single sample.

At 1900 hours on days when sampling the wharf, saltwater intake, or sewage outfall, compositing was done on an equal volume basis from each of the two or three sets of bottles for that site. New brown glass 1250 ml jars were used for final storage. Replicates of each sample were submitted. Log sheets were filled out and submitted to the lab with the samples.

The onshore samples were obtained using Instrumentation Specialties Co. Model 1680 automatic water samplers equipped for discrete sampling. Sampling containers were glass, prewashed with acetone. Samples were taken over a 24-hour period once every 30 minutes. Sample volume was 180 ml. The units were dedicated to the particular sample type (sewage or drinking water) to prevent cross-contamination. Ice was packed around the sample containers to reduce sample loss. The temperature and pH was measured at the beginning and end of a sampling period.

The contingency plan called for analysis of individual hourly or similar short period samples in case of herbicide spillage or other unusual circumstances. This option was not exercised and all samples were composited using a syringe.

All samples were refrigerated after collection. Selected drinking water and other samples having relatively high levels of 2,4-D or 2,4,5-T were archived and shipped to OEHL (Kelly AFB, Texas for later TCDD analysis.

The location of one of the onshore samplers was in the freshwater system equalization tanks immediately downstream from the desalination plant and prior to chlorination (Figure 20). A location upstream of the chlorinator was chosen to mitigate any prior system contamination from HO and to eliminate potential analytical interferences from molecular chlorine or its derivatives. Samples were taken from a tap located at the bottom of the equalization tanks. The total capacity of the tanks is 30,000 gallons (113,550 liters) and the mean hydraulic residence time is 3 days⁽²²⁾. The outflow rate for sampling was approximately 1 gallon/min (3.81/min) which was maintained continuously throughout the assessment.

The sewage samples were drawn from a sump near lift station 2 shown in Figure 22. Pump cycles for discharge of the sewage to the ocean were approximately 5 minutes on followed by 15 minutes off during the day. Nighttime cycles were not observed, but were probably much less frequent because of lower non-domestic discharges. The sampler head was submersed about 2 to 3 feet depending on water level so that solids clogging was minimized. Samples were time proportional (30 minute frequency) rather than flow proportional. Small amounts of solids were found in the samples and were mixed before compositing. Rainwater runoff into the manhole was negligible.

Sediment sampling offshore of the M/V Vulcanus' berth was conducted during the baseline, interim, and post-operational periods. Samples were obtained by divers using scuba equipment (Plate 9). The same prewashed 1250cc amber glass bottles that were used for water samples were also used for sediments.

Sampling locations were about 20 feet directly off the wharf pump area and 30 feet off of the northwest corner in 35-40 ft. of water (Figure 20).

The supernatant water was decanted and the bottles recapped and frozen until shipped to OEHL Kelly Air Force Base, Texas for archiving.

3.2.4 Biological Monitoring Protocol

3.2.4.1 Bioassay Methodologies

Young, potted tomato plants, Lycopersicon esculentum, 25-38 cm tall were used as a biomonitoring organism to detect the presence of Orange Herbicide in the air. Tomato plants were used because of their reported sensitivity to HO damage in parts per trillion range(16). The injury symptom typical of HO damage, known as epinastic growth, is described as a curling and/or twisting of the apical portion of the plant.

Fourteen air biomonitoring sites or stations were selected on Johnston Island as shown on map in Figure 24. The tomato plants, selected for uniformity, were placed at each station. Of the fourteen stations, four designated as D1-D4 were located downwind of the dedrumming area while the remaining 10, designated as U1-U10, were located upwind of this area.

All tomato plants were examined once daily and symptoms of epinastic growth were recorded as being absent, slight, moderate, or severe. Slight injury*, as used herein, is the case where the epinastic growth was limited to the leaf tips and blades. The degree of injury where epinastic growth involved not only the leaf tips and blades but also the leaf petioles, was designated as moderate. Severe injury was characterized by epinastic growth involving the entire apical portion of the plant.

* See Plates 16-19 for pictures documenting these concentrations.

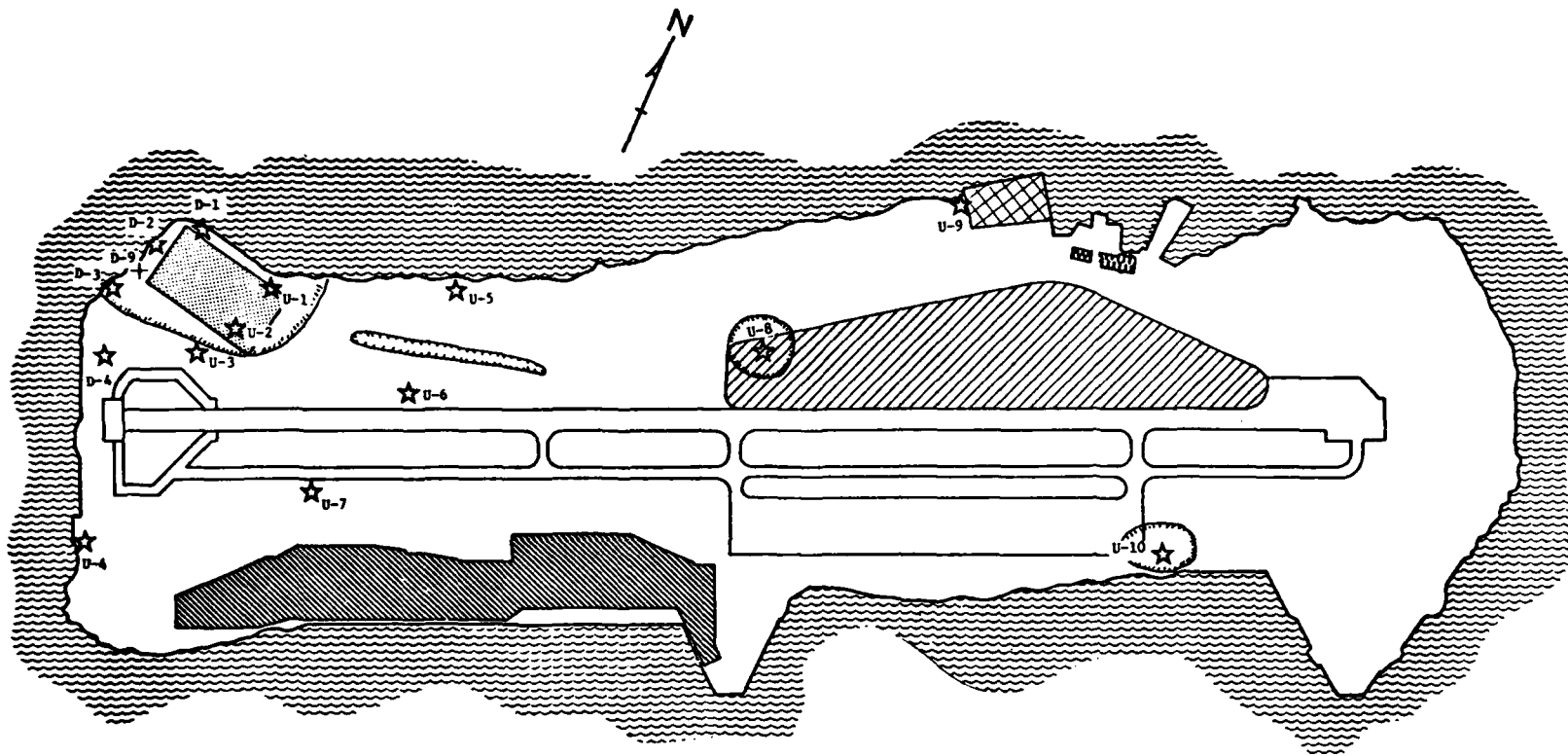

FIGURE 24. BIOTA MONITORING SITES

■ DRAIN YARD

■ RED HAT AREA

■ WEARP

■ ANALYSIS FACILITIES

■ STAFF FACILITIES

★ TOMATO PLANT SAMPLING LOCATIONS

○ BIOLOGICAL OBSERVATION AREAS

+ SUPPLEMENTAL TOMATO SAMPLING LOCATION

The tomato plants were placed at the various stations on Sunday, July 24, and each station was photographed on each successive Saturday through August 27. Tomato plants were also photographed whenever the initial injury symptoms were noted. The plants at each station were changed at least every 1-2 weeks depending on their physical conditions. Whenever the plants at a station were changed a photographic record was made both of the old plants and the new plants which were put in their place.

Because of the high intensity of solar radiation and the constant wind, the tomato plants exhibited a high level of evapotranspirational demand. It was necessary to water the plants twice daily in order to prevent desiccation, and even then wilting was noted occasionally. Four weeks into the operation, the 4-inch plastic pots containing the tomato plants were placed in 1-gallon metal cans and foil was added to fill in around the plastic pot. This procedure improved the water holding characteristics of the growth medium and resulted in relieving much of the moisture stress previously observed.

The wind, which came predominantly from the northeast at speeds of as high as 20 knots, caused considerable physical injury when the tomato plants were first placed at the stations. This problem was resolved by placing a section of screen covered with aluminum foil and/or plastic material on the windward side of the plants.

3.2.4.2 Birds

Because of the large numbers of birds which inhabit the original portion of Sand Island and its relative close proximity to the dedrumming area, Sand Island was chosen as the primary site for monitoring the bird population of Johnston Atoll.* A preoperational bird survey was made

* Sand Island is upwind from Johnson Island. Few birds were observed on Johnson Island before, during or after operations.

on Sand and Hikina Islands on Tuesday, July 26. Bird surveys were repeated on Sand Island each Monday thereafter through August 22. A postoperational survey was made of the bird populations on Akau, Hikina, and Sand Islands on Saturday, August 27. No effort was made to evaluate the effect of dedrumming and transfer operations upon the bird population of Johnston Island because of the very small numbers involved.

The bird surveys included a weekly visual inspection of the birds on Sand Island for possible abnormalities within behavior, distribution, or dead birds.

3.2.4.3 Vegetation

Four areas, which are designated on Figure 24, were chosen for visual examination on a weekly basis for symptoms of herbicide injury. The initial vegetation survey was conducted on Wednesday, July 27 and was conducted each Saturday thereafter through August 27. The survey involved the examination of individual plants and plant parts for symptoms of epinastic growth. All species examined were also photographed to serve as a record.

3.2.5 Analytical Procedures

3.2.5.1 Pre-Departure Tasks

Analytical procedures have been developed and practiced for several years for the trace determination of 2,4-dichlorophenoxyacetic acid (2,4-) and 2,4,5-trichlorophenoxyacetic acid (2,4,5-T) as their methyl and butyl esters. (23-31) These analytical procedures are based on sample preparatory techniques common to pesticide analytical procedures. Pesticide analysis typically consists of a rather complicated and precise series of sequential tasks requiring a good deal of laboratory skill and practice to generate reproducible results. Consequently, it was important to gain sound background information and experience regarding the detailed procedures used for 2,4-D and 2,4,5-T analysis prior to proceeding with routine sample preparation and analysis on Johnston Island.

Since recovery studies reported by other workers for 2,4-D and 2,4,5-T in the water sample preparation scheme was typically 50 percent or less, it seemed important to learn to perform this procedure as reproducibly as possible to assure consistent performance in the field. A series of spiked distilled water samples were carried through this rather involved preparation scheme. As a result, important sources of error and interferences were identified and provisions were made to eliminate these problems.

Additionally, this 2 week pre-departure training allowed the establishment of work schedules and formulation of a general plan for sample preparation and analysis during the JI dedrum operation. The chromosorb and drum rinse sample preparation and analysis schemes were similarly examined.

During the 2 week period prior to departure for JI we also briefly examined the gas chromatographic instrumentation and procedures. A Hewlett-Packard Model 5833A gas chromatograph equipped with dual electron capture detectors (ECD's) was chosen for use because of its accurate flow control, reliable operation, and flexible "firmware" for data acquisition and manipulation. Attendance at a manufacturers' training seminar on the maintenance and operation of this instrumentation, allowed familiarization with the effects of temperature, carrier gas flow rate, composition and purity, and detector and column temperature on precision and accuracy. The formation and determination of the 2-chloroethyl esters as an improvement of the water sample analysis scheme was also examined. However, initial attempts indicated this to be a source of many potentially interfering electron capturing species, and this approach was abandoned.

As a result of several changes in the program schedule, our departure preceded the shipment approximately 900 pounds of equipment by one day and as a result, we were able to monitor the location of this shipment along its route. This equipment consisted of the 2 Hewlett-Packard 5833A gas chromatographs and a variety of general laboratory equipment.

Electron capture detection when used in gas chromatography is an extremely sensitive and selective tool. However, because of its sensitivity, it is very important to (1) vigorously eliminate any unwanted electron capturing species in the samples, (2) use inert and frequently changed

septa, and (3) maintain extremely pure carrier gas supply. As mentioned above, the formation of the 2-chloroethyl esters of 2,4-D and 2,4,5-T was examined as a means to increase sensitivity and avoid the problems of unwanted electron capturing species in the water sample extracts. This procedure consisted of esterifying the acids with 5 ml of 2-chloroethanol/BF₃ reagent at 60 C for 30 minutes. The 2-chloroethyl esters are more sensitive to ECD and are retained longer than the methyl esters with consequently higher operating temperatures. However, the lack of readily available high purity 2-chloroethanol forced a continuation of the BF₃/MeOH esterification procedure.

GC operating conditions were maintained at as high a temperature as possible, and specially constructed column systems and vials were obtained from Hewlett-Packard that were manufactured for high-sensitivity GC-ECD applications. These septa were constructed of an experimental elastomer which gave fewer electron-capture active contaminants than the normally supplied septa. Additionally it was recommended by Hewlett-Packard personnel that we use a Supelco carrier gas purifier Model 2-2315 as an effective way to remove traces of H₂O and O₂ from the carrier gas supply.

The gas chromatographs and associated equipment were shipped by commercial carrier. However, because of its size and weight, the shipment was delayed several times before reaching its destination and was finally transferred to a second carrier who completed the delivery. Despite these manipulations, the equipment arrived intact and undamaged and was immediately installed in the Pacer HO Lab Facility.

3.2.5.2 Pacer HO Analytical Laboratory Description and Operation

The facilities available on Johnston Island for use as the Pacer HO Analytical Laboratory were housed in two air-conditioned buildings located north (upwind) of the wharf area and just east of the small-boat docks (see Figure). The Pacer HO Analytical Facility was established in five rooms within these buildings one for each of the GC's, one for the drum rinse sample, one for the chromosorb and water sample preparation, and one room for cleanup

of the glassware used in the water and chromosorb sample preparation. Because of the risk of contamination of the water and chromosorb samples with the highly concentrated drum rinse samples, the latter were analyzed in a totally separate building.

The drum rinse sample preparation room and the GC used to analyze only the drum rinse samples were housed in Building 130 which was downwind of the water and chromosorb sample preparation facility (Building 120). Also housed in Building 130 were all of the laboratories used by the sample collection team. Although these facilities were air-conditioned, ventilation in the laboratories was not adequate for the large volumes of benzene and highly concentrated drum rinse samples being processed here. Consequently, an additional portable hood was installed in the drum rinse preparation room for all sample manipulations. The sink used for washing glassware was also vented.

Similarly, the water and chromosorb sample preparation room and the dishwashing room required additional ventilation to remove the copious solvent vapors resulting from these operations. One large lab bench was fitted with an overhead blower-equipped vent which also served to draw off ether and acetone fumes from the sink in the glassware cleanup area in the adjacent room. However, the hexane and ether fumes generated during certain stages of the water and chromosorb sample preparation were not efficiently removed by the ventilation system and the lab was occasionally evacuated for this reason. Also, several minor modifications were made in the plumbing and electrical systems for convenience in operating the equipment in the lab. The water and chromosorb sample preparation area was a former rocket fuel analytical lab equipped with a single hood and sink, a non-hooded sink, as well as bench space and several storage cabinets. The glassware cleanup area was located in an adjacent room, with the GC used to analyze these samples in still a third room. A fourth room contained several cabinets and refrigerators and was used for sample storage, while a fifth room was equipped with several desks and was used as an office and clothes change area. (See Plates 10, 11, and 12)

With this arrangement, the sample preparation area was separated from the glassware cleanup, the GC, and sample storage with the objective of eliminating sample contamination from the laboratory environment.

A list of the equipment and supplies furnished by the Air Force and used in the Pacer HO Analytical Lab is given in the appendix. This list has been modified to indicate those items used in the laboratory and an estimate is made of the quantities that were actually needed.

3.2.5.3 Pacer HO Laboratory Management and Operation

The samples that were analyzed in the Pacer HO Analytical Lab included chromosorb, drum rinse and water samples from the land-based monitoring and chromosorb, trace line rinse impinger, water and wipe samples obtained from the ship, M/V Vulcanus. Prior to the first sample analysis, several preparatory tasks were performed.

A series of standard solutions were prepared of 2,4-D and 2,4,5-T methyl and butyl esters spanning the range of 1.5 ppb to 10 ppm. These standards were prepared from two stock solutions of the 2,4-D and 2,4,5-T methyl and butyl esters. The standard curve was obtained by analyzing these methyl and butyl esters by GC and plotting amount injected versus the measured peak area. The slope of this curve is amount/area or the response factor for the peak of interest. The values obtained by the graphical method were compared with those obtained by averaging the response factors for each peak obtained. These response factors were susceptible to change with time so they were monitored frequently by running a standard solution along with each set of samples. Additionally these data were plotted as each of the response factors obtained versus the amount injected. Typical plots of this type are given in Figure 25 and indicate the wide linear range common to pulsed-frequency ECD. Also from these plots, the lower limit of quantitation can be assigned (see Table 5). With increasing use of the instrument, both response and lower detectable limit changed due to fouling of the detector, much of which was reversed by cleaning with large injections of organic solvents followed by a thermal cleaning and rapid purge.

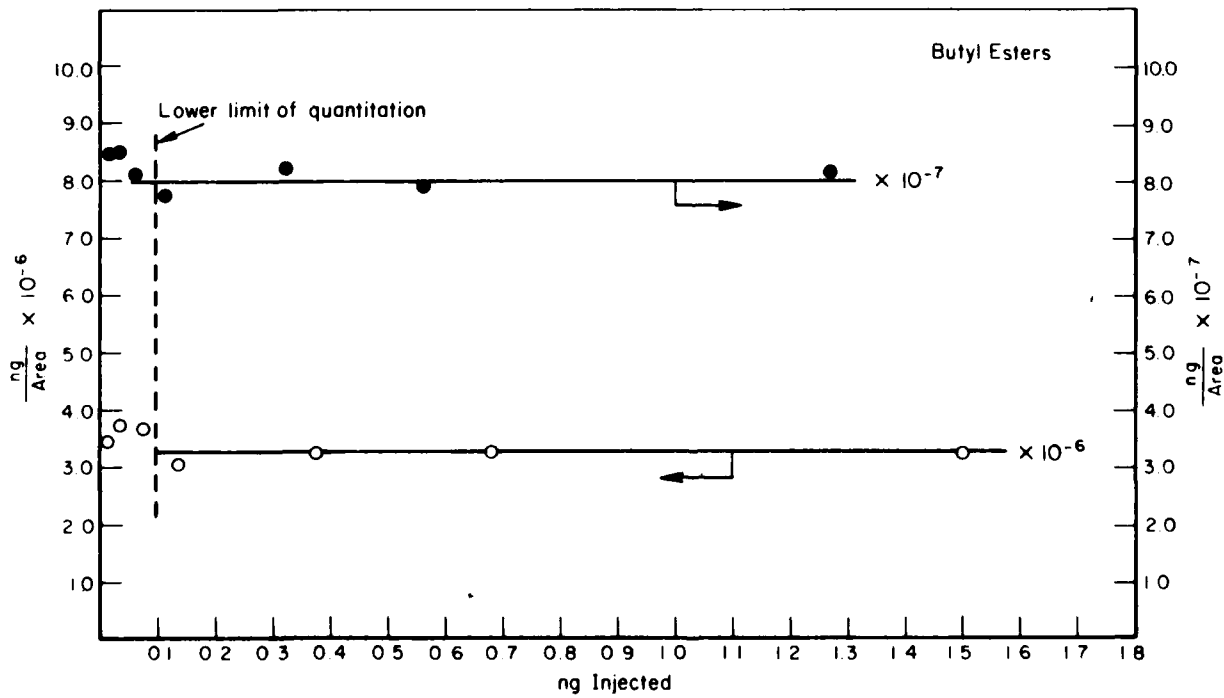
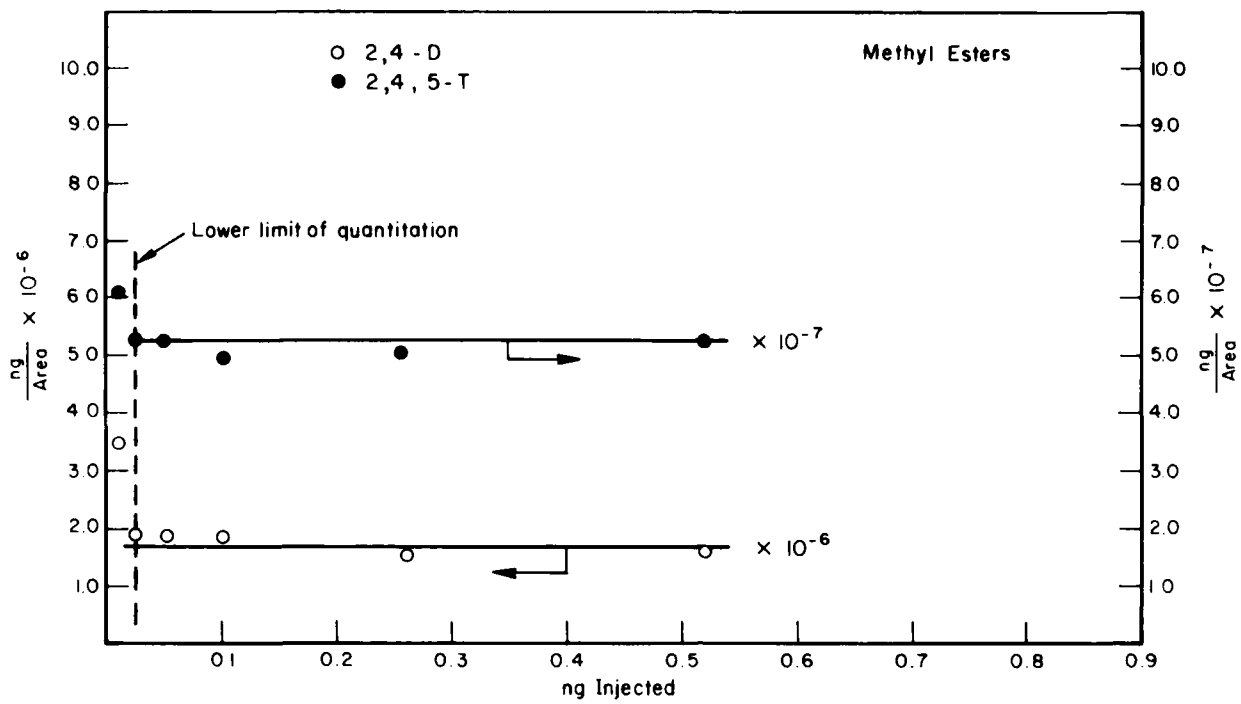

FIGURE 25. CHECK FOR LINEARITY

TABLE 5. RESPONSE FACTORS AND DETECTION LIMITS
FOR METHYL AND BUTYL ESTERS OF 2,4-D
AND 2,4,5-T

		<u>Methyl Esters</u>	<u>Butyl Esters</u>
<u>2,4-D</u>	Response factor	1.667×10^{-6} $\mu\text{g}/\text{area}$	3.29×10^{-6} $\mu\text{g}/\text{area}$
	Lower limit of detection	0.1 $\mu\text{g}/\text{l}$	0.32 $\mu\text{g}/\text{sample}$
	Lower limit of quantitation	0.25 $\mu\text{g}/\text{l}$	0.5 $\mu\text{g}/\text{sample}$
<u>2,4,5-T</u>	Response factor	5.263×10^{-7} $\mu\text{g}/\text{area}$	8.000×10^{-7} $\mu\text{g}/\text{area}$
	Lower limit of detection	0.1 $\mu\text{g}/\text{l}$	0.26 $\mu\text{g}/\text{sample}$
	Lower limit of quantitation	0.25 $\mu\text{g}/\text{l}$	0.5 $\mu\text{g}/\text{sample}$

GC conditions were established and optimized for each of the esters with the following parameters:

- A 6 ft x 2 mm ID glass column was used, packed with 1.50 percent OV-17/1.95 percent QF-1 on 80-100 mesh Chromosorb W-HP
- A 10 percent methane/argon carrier gas
- And the following instrument operating conditions

	<u>Methyl Esters</u>	<u>Butyl Esters</u>
Flow Rate	15 ml/min	25 ml/min
Column Temp.	185 C	190 C
Injector Temp.	260 C	260 C
Detector Temp.	300 C	300 C
Retention Times		
2,4-D	2.26 mins.	2.89 mins.
2,4,5-T	3.75 mins.	4.68 mins.

These rather low flow rates were found to improve the detector sensitivity while not altering resolution. For example, the 2,4,5-T area response increased by a factor of 2.5 in changing from a 50 ml/min. to 20 ml/min. flow rate at 170 C. Also, no unduly rapid fouling of the detector was observed at these flow rates.

A check was made for interferences or impurities in the various solvents used. One liter of each solvent was reduced in volume to 1 ml and injected into the GC. The distilled water was extracted with 3 x 100 ml ether which was reduced to 1.0 ml. Although some impurities were found especially in the distilled water, none was of sufficient concentration or retention time to interfere with the analysis.

3.2.5.3.1 Land Based Monitoring - Water Samples

The water samples examined in the study were prepared using the following method:

- Sample Preparation

- Measure sample volume and quantitatively transfer 1 liter to a 2 liter separatory funnel. (If sample volume is less than 1 liter, then make-up sample difference with distilled water.)
- Acidify to approximately pH 2 with concentrated sulfuric acid.

- Extraction

- Add 150 ml of ethyl ether to the sample in the separatory funnel and shake vigorously for 1 minute.
- Allow contents to separate for at least 10 min. after layers have separated, drain the water layer into a 1 liter Erlenmeyer flask. Transfer the organic solvent layer into a 250 ml ground glass boiling flask containing 2 ml of 37 percent aqueous potassium hydroxide.
- Transfer the water in the 1 liter Erlenmeyer flask to the 2 liter separatory funnel. Rinse flask with an aliquot of 50 ml ethyl ether and transfer to separatory funnel and complete the extraction procedure a second time.
- Perform a third extraction in the same manner.

- Hydrolysis

- Add 10 ml of distilled water and a glass bead to the flask containing the ethyl ether.

- Fit the flask with a 3-ball Snyder column and place on a steam bath. Evaporate the ethyl ether and continue heating for a total of 60 minutes.
- Transfer the concentrate to a 60 ml separatory funnel. Extract the solution 2 times with 20 ml of ethyl ether and discard the ether layers. (The herbicides remain in the aqueous phase since they are in the salt form).
- Acidify the contents of the separatory funnel by adding 2 ml of cold (4 C) 25 percent sulfuric acid. (This changes the herbicides from the salt to the acid form.)
- Extract the herbicides once with 20 ml of ethyl ether and twice with 10 ml of ethyl ether. Collect the extracts in a stoppered 125 ml Erlenmeyer flask containing about 0.5 grams of acidified anhydrous sodium sulfate.
- Allow the extract to remain in contact with the sodium sulfate for approximately 2 hours.
- Sample is ready for methylation. Follow Boron-trifluoride esterification procedure.

Boron-trifluoride Esterification

- Transfer the ether extract, through a funnel plugged with glass wool, into a 125 ml Kuderna-Danish flask equipped with a 1.0 ml graduated ampul. Use liberal washings of ether in the transfer.
- Add 0.5 ml benzene to a Snyder column and evaporate to about 2 ml on a steam bath.
- Remove ampul from flask and add small snyder column and further concentrate the extract to 0.4 ml.
- After the benzene solution in the ampul has cooled, add 0.5 ml of boron-trifluoride-methanol reagent. Cover ampul tightly with solvent-rinsed aluminum foil and hold the contents of the ampul at 50 C for 30 minutes on the steam bath.
- Cool, and add about 4.5 ml of a neutral 5 percent aqueous sodium sulfate solution and transfer to a 20 ml concentrator tube. Rinse 1 ml ampul with 2.0 ml benzene and add rinse to 20 ml concentrator tube.

- Mix on Vortex mixer and allow layers to separate. Remove benzene layer to a 15 ml conical test tube using capillary pipet. Repeat twice more.
- Concentrate benzene extract to 0.5 ml.
- Proceed with Florisil micro-column cleanup.

Micro-Column Cleanup Procedure

- Wash micro-column with 5 ml of hexane and discard washings.
- Place a clean 15 ml tube below the column for collection.
- Quantitatively transfer extract to column. Wash sample test tube with three 0.5 ml of hexane and transfer washing to column.
- Fraction A: Add Eluate a (20 percent methylene chloride in hexane) to the column and elute until 10 ml are collected.
- Fraction B: Place a new test tube under the column and start eluting with Eluate B (50 percent methylene chloride-0.35 percent acetonitrile - 49.65 percent hexane) until 10 ml are collected.
- Evaporate Fraction B down to 0.5 ml. Add 0.5 ml of iso-octane and continue evaporation to 0.4 ml. Make up to 10 ml with iso-octane.
- Sample is ready for gas chromatography. (Place in freezer if samples are not chromatographed when ready.)

Fraction B

2,4-D Methyl Ester
2,4,5-T Methyl Ester

Samples were processed in groups of four with a distilled water blank being included after approximately every tenth sample. A typical chromatogram is shown in Figure 26. All reagents were freshly prepared each week.

Recovery studies were conducted before each dedrum operation and the averaged value used in calculating results for water samples analyzed during that period. These studies consisted of processing distilled water samples spiked with varying amounts of 2,4-D and 2,4,5-T. (See Table 111-26.) Recovery percentages for 2,4-D and 2,4,5-T were 47.4 percent and 54.5 percent, respectively, with an average value of 50.9 percent.

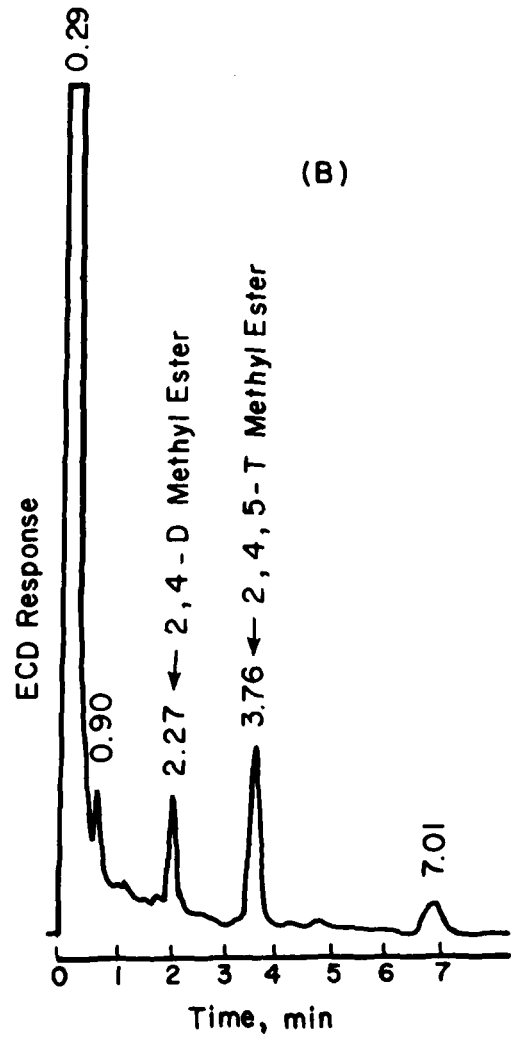
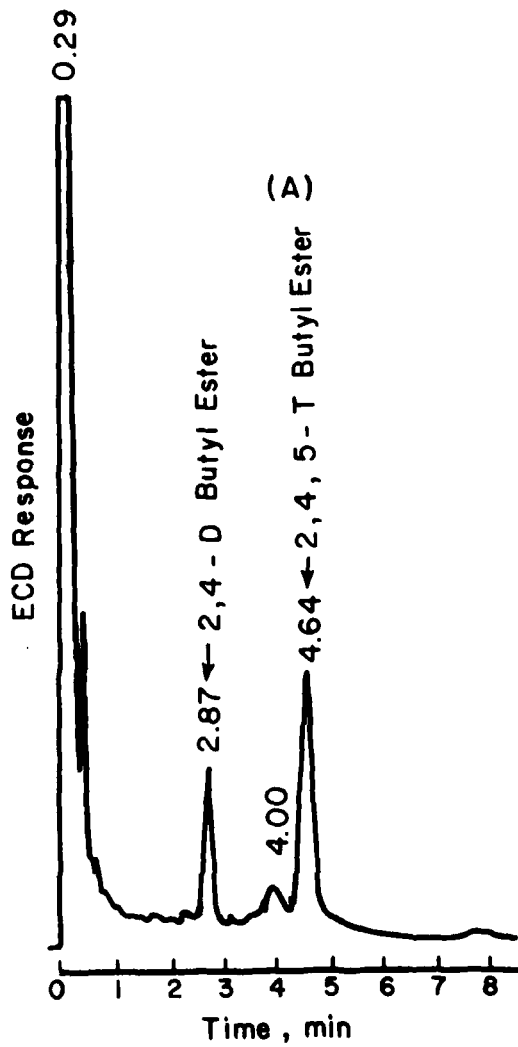

FIGURE 26. GC CHROMATOGRAMS OF (A) CHROMOSORB SAMPLE CD 29Y707J AND (B) WATER SAMPLE WS 30Y700J

Although there appeared to be some differences in the recovery of 2,4-D as compared with 2,4,5-T, these differences were much smaller than the deviation from sample to sample and a single average "correction factor" was used for both esters. This factor was entered into the "firmware" of the GC microprocessor and the data generated directly in units of concentration. These recovery studies were updated periodically and the "correction factor" was adjusted accordingly.

Chromosorb Samples. The chromosorb samples examined in this study were processed as follows:

- Chemical and Materials
 - Chromosorb 102, 60/80 mesh, Johns Manville Corporation.
 - Hexane and acetone of pesticide residue analysis quality.
 - Soxhlet extractors with 250 ml flask.
 - Alundum Soxhlet thimbles.
 - Standards
 - Chromosorb 102 tubes
- Gas Chromatography (Same as water sample procedures)
- Procedure
 - Remove adsorbent and glass wool plug from the collector tube and place in an alundum Soxhlet thimble.
 - Add 150 ml of hexane to the 250 ml Soxhlet extractor flask and extract adsorbent for 1 hour (50 cycles).
 - Concentrate extract to 1 ml and make up to 4 ml with iso-octane for gas chromatography.
- Reports
 - Report concentrations of each n-Butyl ester in micrograms per sample.

The cellulose Soxhlet extraction thimbles were extracted and examined for interferences. As a great many electron-capturing species were observed in the chromatograms of the blank thimble extracts, thimbles were routinely soaked in hexane in a dessicator overnight which was found to be sufficient for removal of these interferences. A typical chromatography of these chromosorb samples is shown in Figure 26.

3.2.5.3.2 Drum Rinse Samples

The analysis of diesel fuel rinse samples was conducted using the following procedure:

- The contents of a sample bottle was agitated by hand for 5 seconds. Using a 0.5 ml volumetric pipet, 0.5 ml of the diesel fuel rinse was transferred to a 5.0 ml volumetric flask.
- The flask was made up to 5.0 ml with pesticide grade benzene and the contents agitated 5 seconds. (Any large rust particles were allowed to settle.)
- Using a 0.2 ml calibrated pipet, 0.1 ml of the above benzene solution was transferred to a 10.0 ml volumetric flask. The flask was made up to 10.0 ml with pesticide-grade iso-octane (2,24-trimethylpentane) and agitated 5 seconds.
- Using a second 0.2 ml calibrated pipet, 0.1 ml of the above iso-octane solution was transferred to a 10.0 ml volumetric flask. The flask was made up to 10.0 ml with pesticide-grade iso-octane and agitated 5 seconds.
- Approximately 2 ml of the final iso-octane solution was placed in each of two GC sample vials labeled with the proper lab code number and the final dilution ratio (1:100,000). The vials were tightly capped. One of the vials was used for analysis of total 2,4-D and 2,4,5-T by GC-ECD. The second vial was archived.

The data collected from the drum rinse samples were presented in both tabular and graphic form. Control charts (see Figures 15 and 16) were constructed to graphically monitor the drum rinse procedure and provide an early warning of possible changes in the efficiency of this operation.

During the dedrum operation, drum rinse samples were obtained approximately once every hundredth drum. Samples were processed and analyzed within 8 hours of their receipt. Chromosorb samples were processed in groups of 12 per day beginning in the afternoon and processing the samples pulled from the morning shift and the previous night shift. Water samples were processed at a rate of 4-5 per day depending upon whether a blank was included or not, and performed on the water samples collected the previous day. To avoid possible conflicts, the water samples were begun at 0530 and required 10 hours for completion such that when the chromosorb sample prep was begun at 1400 hours, the water task was being completed.

3.2.5.3.3 Glassware Cleanup

One of the most crucial steps in any routine trace analytical procedure is the glassware cleanup procedure. In an effort to avoid the small traces of impurities which could ruin the analytical method, a rigorous and thorough glassware washing was employed as follows:

- Separate racks were used for "clean" and "dirty" glassware.
- "Dirty" glassware was not allowed to dry before washing.
- "Dirty" glassware was placed one rack at a time in the chromic acid bath, which was prepared fresh every 10 days.
- Glassware was then rinsed thoroughly with tap water and placed in detergent bath.
- Glassware was scrubbed in a detergent bath, rinsed, and placed in the rinse bath.
- Glassware was rinsed again with tap water and then with distilled water.
- Glassware was placed on "clean" glassware rack and transferred to 150 C oven.
- Glassware was removed from the oven after 1/2 hour, cooled, rinsed with acetone, and stored in closed cabinets.

It should be noted that the use of the cleaned glassware with reagent blanks demonstrated that this glassware cleaning regime was successful.

All rinse and detergent baths were changed after each rack was processed.

3.2.5.3.4 Ship Samples

In addition to the samples collected during the land-based monitoring effort, a number of benzene impinger, trace line rinse, chromosorb, wipe, and drinking water samples were collected on board the incineration ship M/V Vulcanus and analyzed for 2,4-D and 2,4,5-T at the Pacer H0 Analytical Lab. These samples were received upon arrival of the M/V Vulcanus at the end of each burn and were processed and analyzed on a first-priority basis.

Impinger samples were collected in benzene-acetone impingers while trace line rinse samples were taken from the heated trace lines leading from the stack to the impingers as a part of the shipboard incinerator stack gas monitoring program. The analysis procedure for these samples follows:

- Each sample was measured volumetrically.
- The sample was then shaken thoroughly and 1 ml aliquots were withdrawn for GC analysis.
- The remainder of the sample was archived at 4 C.

Many of the impinger samples contained several milliliters of a non-miscible green liquid which was believed to have resulted from aqueous HCl generated during the combustion of the halogen-containing herbicide. Severe corrosion of some of the stainless steel trace lines was observed by ship personnel and the resultant metal salts might account for the green color of this liquid. These samples proved to be quite corrosive to the vial caps and septa, and the GC injection syringes. Several syringes were destroyed as a result of corrosion of the plunger in the needle barrel.

Also severe contamination of the detector was observed after several injections which might be expected from the injection of highly concentrated halogen-containing samples. This required thermal and solvent cleaning before any further analyses could be performed.

Chromosorb, water and wipe samples were collected at different stations within the ship in an effort to monitor its environment for Orange Herbicide contamination. These samples were prepared and analyzed using a procedure similar to that described for the land-based chromosorb and water samples. In addition, a wipe sample recovery study was conducted using standard solutions of the butyl esters of 2,4-D and 2,4,5-T in the following manner:

- Filter paper discs (11.0 and 15.0 cm) were pre-extracted by soaking in hexane overnight and then soaked an additional hour in fresh hexane and air dried.
- These filter discs were then impregnated with measured amounts of butyl ester standards and allowed to dry.
- Each disc was then placed in a Soxhlet extractor and extracted for 2 hours (50 cycles) using 100 ml hexane.
- The extract was then diluted to 100 ml and analyzed by GC.

The results of these recovery studies are given in Table III-27, and show average recovery as ranging from 154 percent at low concentrations to 108 percent at high concentrations. Some interfering compounds were present in these samples, probably originating from the filter paper discs. However, as evident from Table III-27, these interferences presented a serious problem only at very low levels since many of the wipe samples analyzed contained considerably in excess of 10 μg , further refinement of this procedure was not considered to be warranted.

At the completion of the dedrum and loading operation, the refueling vehicles were rinsed to remove all waste material associated with the disposal operation. Wipe samples were taken from the inside of each refueling vehicle and analyzed as described above. Also, during the incineration of the dunnage material, high volume impingers were operated and the filter discs were analyzed as described for the wipe samples.

3.2.6 Spill Prevention and Countermeasure Plan

Personnel involved with the project on Johnston Island were briefed on spill prevention, countermeasures, and personnel safety (see below) on July 23, 1977. The following equipment was inspected and pre-positioned in the event of use:

- (A) 10,000 and 50,000 gallon bladders at dock.
- (B) Submersible pump with hoses in Building 303, adjacent to dock. This building was always open for easy entry.
- (C) One pallet in the dedrumming area containing:
 - (1) One electric pump (10 GPM) with 25 ft hose.
 - (2) One portable electric generator for electrical power.
 - (3) 25-30 Sand bags.
 - (4) 3 Shovels.
 - (5) 3 Squeegees.
 - (6) 2 Bags of absorbent material.
 - (7) 2 Rolls of plastic (100 ft x 20 ft each).
 - (8) 2 Instant foam kits.
- (D) One PMU-27 in the dedrumming facility next to the above pallet.

As at Gulfport, the dock pumps were positioned inside a sandbagged area lined with plastic ground cloth in order to "pool" any spilled herbicide.

3.2.7 Safety Plan

(1) All personnel working inside the dedruming facility were supplied with coveralls, rubber gloves, splash aprons, rubber boots, face shields, and respirators. Use of this protective equipment was mandatory throughout the entire operation (Plate 13).

(2) The change room was located on the ground floor of Building 250. Workmen were to shower and change into clean clothing at this location before leaving to enter the mess hall or other buildings on the island. The contaminated coveralls were laundered daily.

(3) Smoking was prohibited inside of or near the dedrumming site. Breaks were to be taken at one of the two rest areas provided, either at the Fox Plant 200 yards southwest of the facility or in the area of the clerk's offices nearby to the northeast. Gatorade and fresh fruits were provided for refreshment.

(4) Because Herbicide Orange has an oily texture and splashing onto the smooth, concrete floor of the facility was unavoidable, a cleaning solvent was utilized so that spills could be immediately washed into the drainage gutter.

(5) In order to provide adequate ventilation for the dedrumming facility, the walls remained rolled opened, thus taking advantage of the island's near constant 15 MPH trade winds.

(6) The access road between the dedrumming operations area and wharf was graded and adequately marked to insure safe passage of the R-5 refuelers.

(7) During the loading and unloading of the R-5 refuelers a ground wire was attached between the truck and pump. A fire truck was also stationed on the wharf throughout operations.

(8) Key personnel of the Air Force, Holmes and Narver, TRW, and Battelle were equipped with two-way radios for the purpose of immediate notification in the event of accidents, spills, or procedural deviations.

4. ENVIRONMENTAL IMPACTS OF LAND-BASED OPERATIONS

4.1 HO Impacts on Natural Environment of Johnston Island

4.1.1 Land

The only land impacts associated with the disposal area were the commitment land for storage of the crushed drums, and an area of slightly contaminated soil around the dedrumming facility and the drum crusher.

The dedrumming activities made the land previously used as a drumyard available for other uses. However, the land is contaminated with HO, not due to the disposal operation. The Air Force is monitoring the soil contamination (see Section 6.6).

4.1.2 Air

A total of 156 chromosorb tube air samples were drawn before, during, and after the operations at Johnston Atoll. Figures 17, 18, and 19 present the locations of the fixed samplers. The concentration data for all samples are presented in the Level III report. It is seen from these data that the maximum concentrations observed at any station were 40.3 and 22.5 $\mu\text{g}/\text{m}^3$, for the 2,4-D and 2,4,5-T isomers, respectively, several orders of magnitude below the OSHA* TWA's of 10,000 $\mu\text{g}/\text{m}^3$.

A summary table of all observed air concentrations is presented as Table 6. These data are discussed further below.

4.1.2.1 Weather Station (CM)

This site was established as a background station, located as far as possible upwind of all of the HO activities. Yet low 2,4-D and 2,4,5-T concentrations (averaging 0.24 and 0.05 $\mu\text{g}/\text{m}^3$, respectively) were

* The OSHA-ACGIH TWA values are allowable exposures for an 8 hour time weighted average. The TWA values are for 2,4-D and 2,4,5-T acids, and are explicitly stated for either as 10 mg/m^3 . There are no ambient air quality standards for the esters of 2,4-D or 2,4,5-T.

TABLE 6. SUMMARY OF ALL CONCENTRATIONS AT AMBIENT AIR MONITORING SITES (Ug/m³)

Site	Interval	No. of Samples	2,4,5-T Mean	2,4,5-T Stand. Dev.	2,4-D Mean	2,4-D Stand. Dev.	* Percent Below Quantitative Detection Limit	
							2,4,5-T	2,4-D
Weather station (CM)	Pre-operational	3	0	0	0	0	100	100
	First load	11	0	0	0.25	0.39	100	64
	Interim	3	0	0	0	0	100	100
	Second load	11	0.10	0.34	0.23	0.77	91	91
	Post-operational	4	0	0	0	0	100	100
Wharf station (CW)	Pre-operational	3	0	0	0	0	100	100
	First load	11	0	0	0.29	0.42	100	64
	Interim	1	0	0	0	0	100	100
	Second load	7	0	0	0	0	100	100
	Post-operational	4	0	0	0	0	100	100
Downwind station (CD)	Pre-operational	3	0.08	0.13	0.49	0.85	67	67
	First load	15	2.11	1.07	4.60	2.27	0	0
	Interim	2	2.49	0.73	5.91	1.92	0	0
	Second load	11	4.50	2.01	10.74	3.96	0	0
	Post-operational	5	4.55	1.86	10.39	4.52	0	0
CS (Southwest corner of facility)	Pre-operational	1	0.57	0	1.60	0	0	0
	First load	3	8.12	1.05	14.84	1.77	0	0
	Interim	0	--	--	--	--	--	--
	Second load	1	7.35	0	18.78	0	0	0
	Post-operational	4	2.61	0.88	7.80	2.10	0	0
CN (Northwest corner of facility)	Pre-operational	1	0	0	0	0	100	100
	First load	3	4.58	3.24	9.99	7.30	0	0
	Interim	0	--	--	--	--	--	--
	Second load	1	2.27	0	6.60	0	0	0
	Post-operational	5	2.85	0.80	7.13	1.57	0	0
CP (Center of eastern wall of facility)	Pre-operational	1	0.75	0	1.87	0	0	0
	First load	3	0	0	1.07	1.37	100	33
	Interim	0	--	--	--	--	--	--
	Second load	0	--	--	--	--	--	--
	Post-operational	0	--	--	--	--	--	--

* 0 was used for non-detectable in averaging concentrations.

found during the two dedrumming periods. The possibility of these concentrations being due to lab contamination is discounted because of the correlation of observations to dedrumming activities. Had lab contamination existed, it would.

Contamination is virtually ruled out by the complete absence of measurable concentrations during the interim and the pre- and postoperation intervals. Furthermore, the rainwater collected at the weather station was contaminated slightly with 2,4-D and 2,4,5-T, further substantiating the measured air concentrations.

The most logical explanation of the observed concentrations, given the constancy of the wind direction, is that of upper air recirculation. While no data were taken on upper air winds, cloud observations occasionally indicated the possibility.

Furthermore, the atoll area is a heat island, and does have micro-scale impacts on weather. Perhaps the heat island effect is responsible for recirculation. At any rate, the observed concentrations were exceedingly low (averaging 20.5 and 3.8 parts per trillion), and no adverse impacts were observed.

4.1.2.2 Wharf

The wharf site (Plate 14) was situated to measure any 2,4-D and 2,4,5-T air concentrations resulting from ship loading which could impinge on the island. The site was located west and as far north as possible on the wharf, as the wind direction was from the east and south. Frequently, the R-5's were parked close to and upwind of the sampler. Furthermore, the R-5's had to pass upwind of the samplers to travel to and from the ship loading point. For these reasons, it was expected that the wharf sampler might measure HO concentrations.

In fact, nearly all of the samples taken at the wharf during dedrumming activities showed trace, but non-quantifiable (below about $0.8 \mu\text{g}/\text{m}^3$, but dependent on sample volume) quantities. Several of the samples for the first dedrumming were quantifiable, yielding average concentrations for the first dedrumming period of 0.29 and $0.42 \mu\text{g}/\text{m}^3$ for 2,4-D and 2,4,5-T, respectively. The peak 2,4-D concentration was $1.09 \mu\text{g}/\text{m}^3$, comparing favorably to the OSHA TWA of $10,000 \mu\text{g}/\text{m}^3$.

The tomato plants located ~ 30 meters west of the site did not suffer HO damage, which would be expected at long term exposures to greater than 10 parts per trillion.

4.1.2.3 Downwind Station

This station, being partially downwind of the drums, was expected to have preoperational concentrations of HO. Furthermore, being directly downwind of the dedrumming facility, the site could be expected to react to dedrumming activities. In fact, both phenomena occurred.

Figure 27 was prepared to help visualize the causes of the observed concentrations. In addition to the plotted concentrations, the trend lines for the two dedrumming periods (least squares fit) are attached.

The initial concentrations were trace amounts. On the 26th of July, measurable concentrations were found: during that day dedrumming activities were demonstrated to the dedrumming staff.

From the 27th July to the 4th August, concentrations at the downwind site continued to climb. A noticeable drop occurred on the night of the 31st July following the dedrumming activities pause on the 30th July.

On these days, as in the second dedrumming period, concentrations during the day were noticeably higher than at night. Several conditions could have accounted for this, as noted below:

2,4-D

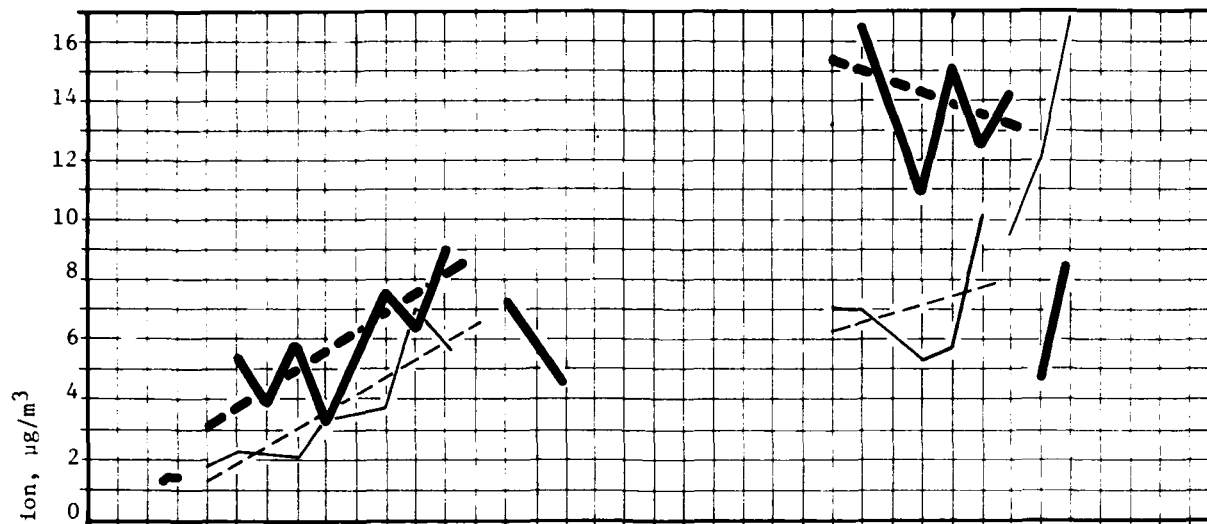

2,4,5-T

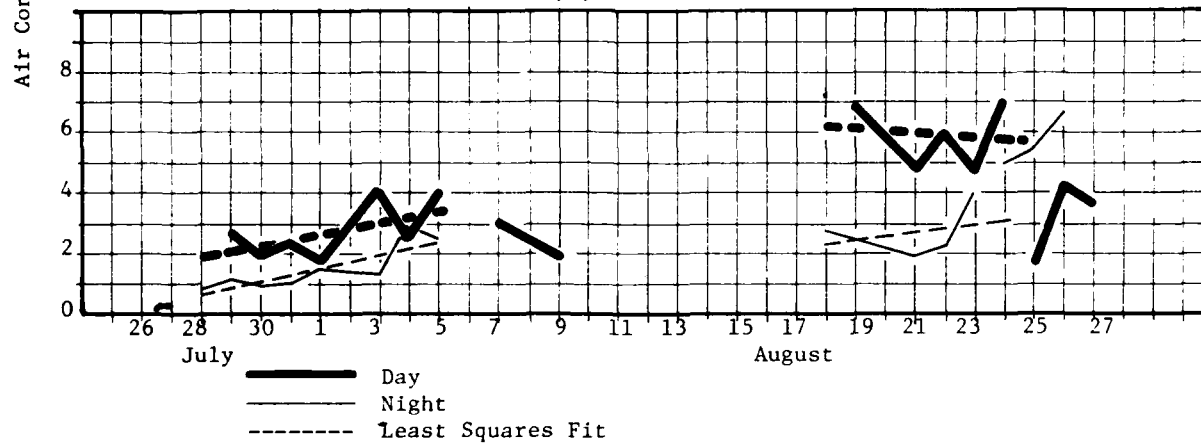

FIGURE 27. CONCENTRATIONS MEASURED AT DOWNWIND STATION

- (a) The dispersion capabilities of the air. However, there was no quantifiable difference in wind speeds between morning and night, the most probable cause in dispersion differences.
- (b) Differences in operating personnel. There were observable differences in the job performance of the dedrumming staff between day and night shifts. However, when the trend line is considered, the carry-over of contaminants between shifts would obscure shift differences.
- (c) Insolation. Incoming solar radiation (and conversely, nighttime earth radiation) caused the land surface to suffer temperature extremes in excess of the ambient air temperature.

Reference (40) shows that the evaporation rates are approximately related to the logarithm of the temperature, and that the rate may double or even triple between 60 F and 80 F. This factor is sufficient to explain the differences between observed day and night concentrations.

The increasing concentrations are interesting. The most likely explanation of these is that, in removing barrels for dedrumming, the ground underneath the barrels, which in many cases had absorbed H₀, was freshly exposed to the elements. The ever increasing area thus allowed more and more evaporation to take place, increasing observed concentrations.

If this explanation were correct, it would be expected that concentrations would decrease when dedrumming activities ceased. This is in fact observed in the first days after completion of the first dedrumming.

Concentrations during the second dedrumming period were noticeably higher than the first, but no general trend statement can be made with statistical confidence. Again, daytime concentrations were higher than nighttime concentrations.

During the post-operational phase, the start times for the night sample moved from 1900 to 1700 to 1600. Whereas the day time sample reflects the expected drop in concentrations, the nighttime sample actually increases. This would be consistent with the previously expressed belief that solar insolation/air temperatures are the predominant effect in the evaporation rate of the H₀.

Further observations in the postoperative period were invalidated by the discovery of interfering contaminants on the chromosorb tubes used. Table 7 illustrates the mean values of 2,4-D and 2,4,5-T concentrations during intervals of interest at the downwind station.

TABLE 7. CONCENTRATION AVERAGES AT DOWNWIND STATION

Interval	Concentration, $\mu\text{g}/\text{m}^3$		
	2,4-D	2,4,5-T	No. Samples
Pre-operational (day)	0.49	0.08	3
First load (day)	5.5	2.6	7
First load (night)	3.4	1.3	8
First load (combined)	4.6	2.1	15
Interim (day)	5.9	2.5	2
Second load (day)	14.1	5.3	5
Second load (night)	5.8	2.0	6
Second load (combined)	10.7	4.5	11
Post-operational (day)	6.6	2.8	2
Post-operational (mixed)	12.9	5.7	3
Post-operational (combined)	10.4	4.6	5

4.1.2.4 Dedrum Facility

Fixed monitors were located on the perimeter of the dedrum facility (Plate 14) to measure air concentrations at the facility boundaries. Site CP was essentially on the upwind side of the building: concentrations there being low during preoperations and first load, measurements at the site were discontinued.

Concentrations on the downwind corners of the building were also monitored. Table 8 presents their composited measurements.

TABLE 8. CONCENTRATION AVERAGES AT DEDRUM FACILITY

Interval/Measurement, $\mu\text{g}/\text{m}^3$	2,4-D	2,4,5-T	No. Samples
Pre-operational	0.8	0.3	2
First load	12.4	6.4	6
Second load	12.7	4.8	2
Post-operational	7.4	2.7	9

These concentrations demonstrate the expected pattern of high values during dedrumming and lesser values before and after. There was no demonstrated chronological trend in the post-operational measurements. However, daytime concentrations during loading (14.9 and $6.7 \mu\text{g}/\text{m}^3$ for 2,4-D and 2,4,5-T) were higher than nighttime concentrations (10.0 and $5.3 \mu\text{g}/\text{m}^3$, respectively) as was experienced at the downwind site. All values were well below OSHA TWA of $10,000 \mu\text{g}/\text{m}^3$.

4.1.2.5 Tomato Plant Bioassay

The tomato plant bioassay was developed to provide a real-time monitoring system for detecting the presence of HO in the air of Johnston Island. As stated earlier, the sensitivity of tomato plants to HO is on the order of a few parts per trillion and at this or higher concentrations a response is generally seen within a matter of a few hours.

Tomato plants were placed at the 14 biomonitoring stations on Sunday, July 24, and observations were made for the next three days to establish a baseline with respect to tomato plant injury. The dedrumming operation began on Wednesday, July 27, and was completed on August 23. However, there was an interruption in the dedrumming operation between August 5, and August 17 while the M/V Vulcanus was performing the second burn.

Near the end of the study, three days prior to the completion of the dedrumming operation, six additional tomato plant stations were established in an effort to more closely delineate the area of highest herbicide concentration. Five of the six stations were located downwind of the dedrumming facility while the remaining station was located about 20 feet upwind of the facility (Figures 18 and 24). Four of the five additional downwind stations (D-5 through D-8) were located on a transect about 100 feet from the dedrumming facility. The fifth downwind station was located between stations D-2 and D-3.

A rating system was devised to evaluate plant damage. Photographs showing the actual damage are presented in Plates 15 through 18.

The results of the tomato plant bioassay are shown in Table 9. The 3 days of preoperational observations indicated that concentrations of HO sufficient to cause severe injury to tomato plants existed in the vicinity of stations D-2 and D-3. These two stations were located about 500 feet downwind of the dedrumming facility (Figure 24). No injury was observed in the two remaining downwind stations or the 10 upwind stations.

Tomato plant observations which were made during the period July 28 through August 24 indicated that relatively high concentrations of the herbicide existed not only in the vicinity of stations D-2 and D-3 but also on occasion at stations D-1 and D-4. Severe injury was observed at stations D-2 and D-3 consistently except for three days. Herbicide injury was not observed in any of the 10 upwind stations during this period except for the two instances of slight injury observed on August 15 and 16 at station U-1 with unknown cause.

The degree of tomato plant injury observed during the 3-day post-operational period was similar to that observed prior to the start of the disposal operation. Severe injury was observed at stations D-2 and D-3. A lesser degree of injury occurred at D-1 while injury was absent at station D-4.

The degree of tomato plant injury observed at the six additional stations was consistent with that observed at the original stations. Severe injury occurred at the five downwind stations as well as the one upwind station.

The results of the tomato plant bioassay indicate that during the dedrumming operation concentrations of HO above the sensitivity of tomato plants did not occur upwind of the dedrumming/storage facility on Johnston Island. However, significant concentrations of the Herbicide did occur directly downwind of this facility and on occasion extended laterally to the two outlying tomato plant stations. It is interesting to note that significant concentrations of HO occurred in this area prior to the start of the disposal operation.

4.1.2.6 TCDD

The benzene impinger samples were sent to the Air Force for analysis by another contractor. As of this writing, a total of 20 samples from all locations had been analyzed. No TCDD was found in any sample. Minimum detectable concentrations ranged from 6.64 to 20.34 nanograms per cubic meter.

4.1.3 Water

The water environment acts as a transport medium for pollutants. Water quality measures environmental effects that may or may not have impacts associated with them. Whether a given level of a pollutant results in an impact depends on the subsequent biological response. Insofar as response measured in static bioassay testing may not be representative of environmental conditions, assignments of impacts via water concentrations are subject to error.

Data obtained during the operational and postoperational phases of the assessment are presented for each of the six water sampling sites and compared to baseline levels to determine if any statistically significant changes occurred. The data are further compared against applicable water quality criteria and/or standards. Water data summaries are shown in Tables 10, 11, and 12. Figures 20, 21, 22, and 23 define the water sampling locations.

4.1.3.1 Dedrum Area Offshore (Site WD)

Samples taken offshore of the dedrum area before, during, and after Operation Pacer HO showed no 2,4-D and traces (0.1-0.2 ppb) of 2,4,5-T in two of three operational or postoperational samples. Baseline samples taken by the Air Force showed quantifiable or trace levels in over 53 percent of the samples taken in this area between 1973 and 1977. Trace levels of 2,4,5-T were also found in the baseline sample taken by BCL on July 24.

It is therefore concluded that HO dedrum and transfer operations did not have adverse effects on the water environment offshore from the drum storage yard. Measurable concentrations of herbicide due to contaminated soils and interchange of shallow groundwater with offshore water will continue to produce occasional instances of HO contamination. The trace levels observed by BCL did not exceed established water quality criteria of 0.3-5 ppm and are considered negligible.

TABLE 10. WATER DATA SUMMARY
OPERATIONAL

Location	No. Samples	Maximum in PPB		Minimum in PPB		Positive Average in PPB		Percent Positive		Percent Trace		Percent N.D.	
		D	T	D	T	D	T	D	T	D	T	D	T
WS saltwater intake	15	2.11	1.32	<.1	<.1	1.05	.60	29	36	29	50	43	14
WF wharf	17	4698.1	3418.5	<.1	<.1	791.3	496.4	38	44	25	31	38	25
WO wastewater outfall	7	<.1	Trace	<.1	<.1	--	--	0	0	0	43	100	57
WD downwind dedrum	2	<.1	<.1	<.1	<.1	--	--	0	0	0	0	100	100
PI&P2 potable water	16	<.1	Trace	<.1	<.1	--	--	0	0	0	80	100	20
SE1&SE2 sewage	9	65.63	72.15	8.93	11.77	32.08	32.42	100	100	0	0	0	0
RW rainwater	1	<.1	Trace	<.1	<.1	--	--	0	0	0	100	100	0

TABLE 11. WATER DATA SUMMARY
INTERIM

Location	No. Samples	Maximum in PPB		Minimum in PPB		Positive Average in PPB		Percent Positive		Percent Trace		Percent N.D.	
		D	T	D	T	D	T	D	T	D	T	D	T
WS saltwater intake	3	Trace	Trace	<.1	<.1	--	--	0	0	33	66	66	33
WF wharf	3	.38	.36	<.1	Trace	.38	.32	33	66	33	33	33	0
WO wastewater outfall	0	--	--	--	--	--	--	--	--	--	--	--	--
WD downwind dedrum	0	--	--	--	--	--	--	--	--	--	--	--	--
Pl&P2 potable water	3	<.1	Trace	<.1	<.1	--	--	0	0	0	33	100	66
SE1&SE2 sewage	9	20.35	21.76	12.26	13.59	16.30	17.67	100	100	0	0	0	0
RW rainwater	1	<.1	<.1	<.1	<.1	--	--	0	0	0	0	100	100

121

TABLE 12. WATER DATA SUMMARY
POST OPERATIONAL

Location	No. Samples Taken	Maximum in PPB		Minimum in PPB		Positive Average in PPB		Percent Positive		Percent Trace		Percent N.D.	
		D	T	D	T	D	T	D	T	D	T	D	T
WS saltwater intake	3	<0.1	T	<0.1	<0.1	0	0	0	0	0	33	100	67
WF wharf	3	<0.1	T	<0.1	<0.1	0	0	0	0	0	33	100	67
WD dedrum offshore	1	<0.1	T	<0.1	T	--	--	0	0	0	100	100	0
WO wastewater outfall	1	<0.1	<0.1	<0.1	<0.1	--	--	0	0	0	0	100	100
Pl&P2 potable water	3	<0.1	<0.1	<0.1	<0.1	0	0	0	0	0	0	100	100
SE1&SE2 sewage	2	3.88	2.83	1.42	0.89	2.65	1.86	100	100	0	0	0	0
RW rainwater	0	--	--	--	--	--	--	--	--	--	--	--	--

122

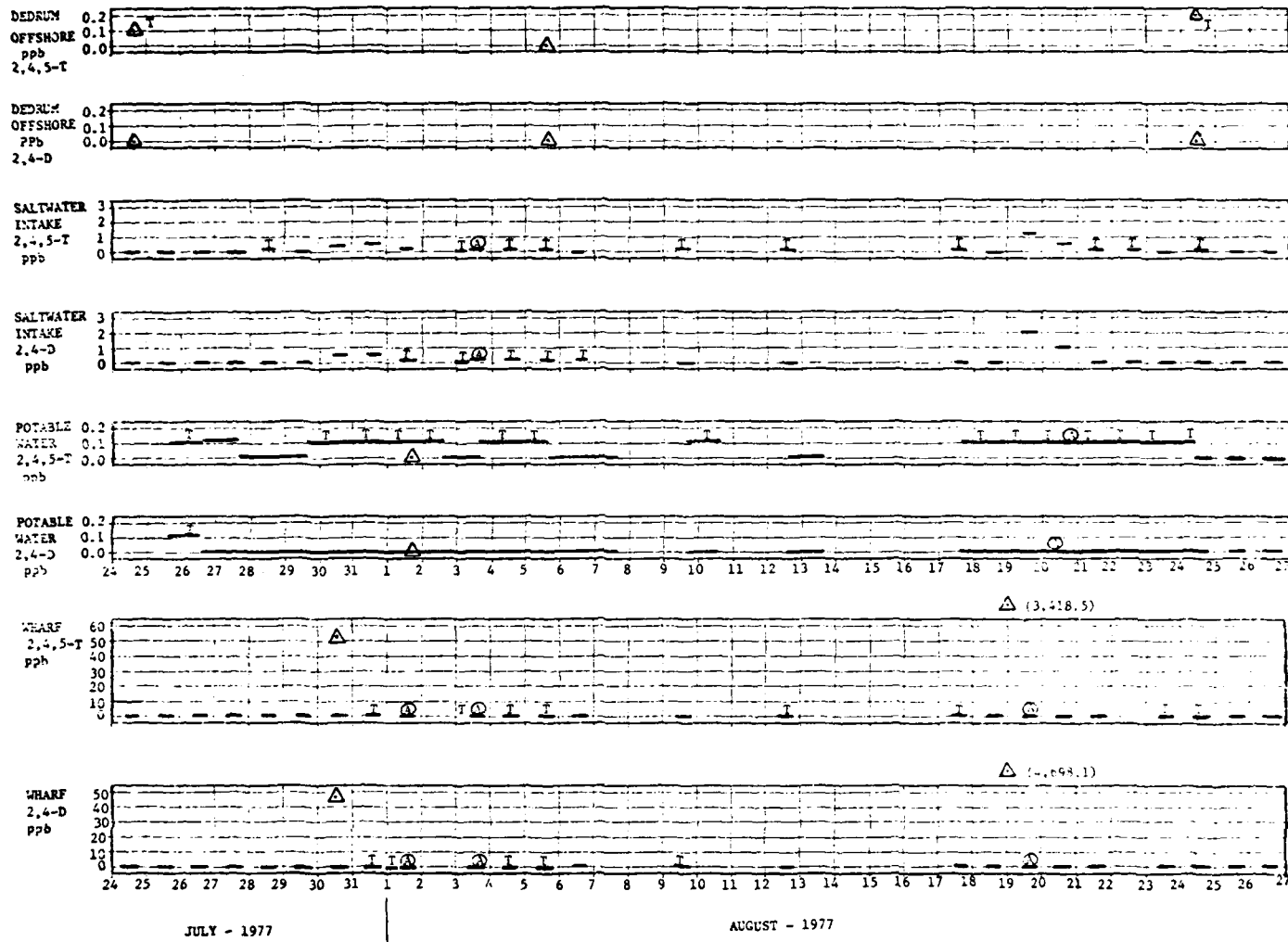

FIGURE 28. CHRONOLOGICAL PROFILE OF WATER CONCENTRATIONS CONTRASTED WITH THE DEDRUMMING ACTIVITIES

124

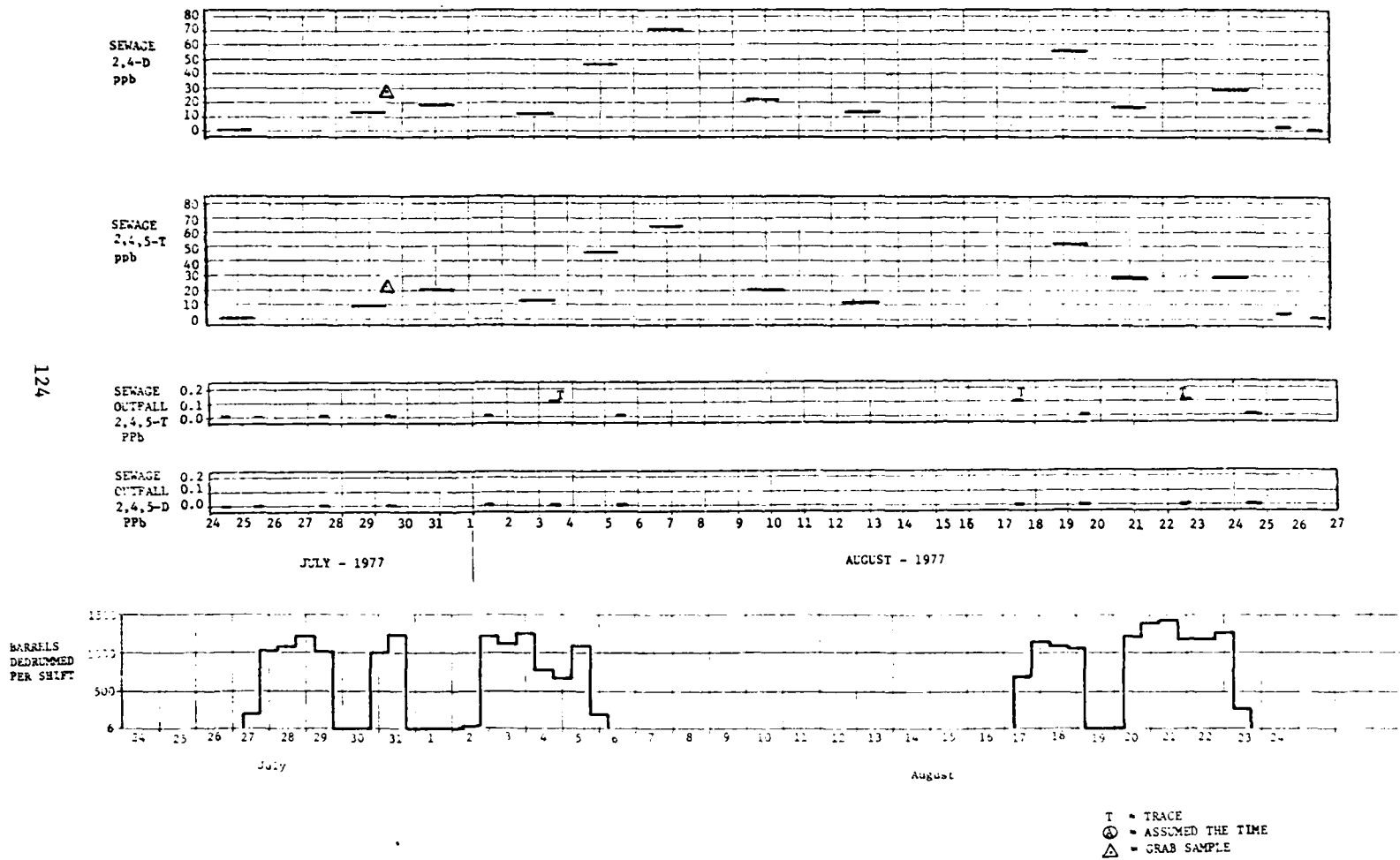

FIGURE 28. (Continued)

4.1.3.2 Wharf (Site WF)

A total of 17 operational, three interim, and three postoperational samples were analyzed and showed positive averages for 2,4-D of 791.3 ppb, 0.38 ppb, and <0.1 ppb for the above periods, respectively. Corresponding results for 2,4,5-T were 496.4 ppb, 0.32 ppb, and a trace. The highest values observed were related to the two 24-hour deballasting periods during which bilge water contaminated with Orange Herbicide was pumped from the M/T Vulcanus into the lagoon water.

The first of these events occurred on July 31. At 1100 hours, a patch of orange-hued water was observed along the port side of the ship just astern of the deballast pump discharge. A sample of this water was taken from about one meter depth contained 47.57 ppb of 2,4-D and 54.14 ppb of 2,4,5-T. By 1400 hours the area affected by the deballast discharge had increased to include the entire port side of the ship and about 5 meters forward of the bow and 5 meters aft of the stern. At 1800 hours the plume was noticeably less distinct and presumably had sunk and/or dispersed. Since the concentrations were at the low end of the toxicity range and did not persist for more than 8 hours, it is reasonable to conclude that no adverse impacts occurred. Furthermore, the relatively small area involved would not preclude fish from avoiding the area altogether for this short period. No distress effects were noted in any fish or other aquatic life and concentrations in the composited wharf sample taken over a larger area were 0.45 ppb 2,4-D and 0.41 ppb 2,4,5-T well below published toxic concentrations of 0.3-5 ppm. No biological specimens were collected.

A similar situation existed during the second deballast period on the 19th of August. A sample taken of the water about 10 feet (3 meters) astern of the discharge at 1000 hours showed 4698.1 ppb of 2,4-D and 3418.5 ppb of 2,4,5-T. At this time, the plume extended approximately 20 feet (6.1 meters) in both directions between the ship's hull and the wharf. The total volume of water discharged on this date was 1500 m³ (396,000 gallons; 1.5×10^6 l).⁽³⁸⁾ A "worst case" scenario would be that the concentrations as measured in the lagoon were invariant during this

time period. A conservative dilution factor of 10 was estimated in which case 155 lb (70.7 kg) of 2,4-D and 113 lb (51 kg) of 2,4,5-T were released to the marine environment. Put in perspective, this means that, at 10.7 lb per gallon, approximately 25 gallons of pure herbicide was released. This corresponds to about 1/2 drum as an absolute maximum.

In both instances, the plume edges were sharp and distinct, and the plume was confined to near the ship, in spite of wharf currents. The rapid disappearance of the plume is attributed to the fact that HO, heavier than water, and immiscible in water, sinks. It is expected that the discharged HO sank to the bottom of the ship channel and then spread out. Concentrations observed at the saltwater intake support this belief. These concentrations demonstrated that the HO rapidly dispersed to insignificant concentrations.

The resulting concentrations were above the suggested aquatic life criteria. However, in view of the fact that the area of impact was limited and the exposure time relatively short, it is believed that the adverse impacts, if any, were minor. No visible signs of distress were noted in fish swimming near the wharf. The concentrations in the composite wharf sample for August 19 were 0.33 ppb 2,4-D and 0.25 ppb 2,4,5-T, and on August 20 were 1.02 and 0.88 ppb, well below the suggested quality criteria of 0.3-5 ppm. Values of 0.38 ppb 2,4-D and 0.36 ppb 2,4,5-T noted on August 6 were probably due to wash down of the decks following final sampling of the ship's tank just prior to departure. These concentrations posed no danger to the aquatic life.

The median concentration for all operational samples taken at the wharf was \leq 0.2 ppb.

Measurable concentrations of Orange Herbicide have been found at this location on three occasions in the past by the Air Force.⁽¹⁶⁾ The maximum concentrations were 0.54 ppb 2,4-D and 0.29 ppb 2,4,5-T and the positive average concentrations were 0.31 ppb and 0.22 ppb. The median concentration for 52 samples was \leq 0.2 ppb.

Samples taken by BCL during the baseline period showed no detectable levels of HO.

It is concluded that concentrations of herbicide significantly exceeded baseline concentrations on three occasions during the assessment. On one of these occasions the concentrations exceeded the upper aquatic life criterion of 5 ppm by at least 60 percent. Acute impacts were not directly observed.

4.1.3.3 Saltwater Intake (Site WS)

As mentioned previously (Section 2.1.3.2), the local circulation during certain tidal movements allows the water mass to move from the vicinity of the main wharf to the intake for the island's water system. At a speed of one knot, a parcel of water at the wharf could be easily transported the short distance to (480 meters) to the intake in a short period of time.

Baseline samples taken by BCL showed no detectable Orange Herbicide. Baseline samples taken by the Air Force between 1973 and 1977 had quantifiable or trace levels of 2,4-D six times and of 2,4,5-T 10 times. The maximum concentrations of 2,4-D and 2,4,5-T were 2.31 and 0.65 ppb, respectively.

Fifteen operational samples taken by BCL showed maximum concentrations of 2.11 ppb 2,4-D and 1.32 ppb 2,4,5-T. Twenty-nine percent of the samples were in excess of 0.2 ppb 2,4-D and 36 percent were above 0.2 ppb for 2,4,5-T. The value of 0.2 ppb is the limit of quantitation of the analytical method. No samples were in violation of currently accepted drinking water standards of 100 ppb 2,4-D even when applied to the intake side of the system and were never greater than 50 percent of the more stringent no-effect level for 2,4-D (4.4 ppb). The maximum concentration of 1.32 ppb 2,4,5-T is an even lower percentage of the no-effect level of 35 ppb.

The chronological profile of concentrations of herbicide at the various sites is contrasted in Figure 28 with the number of barrels dedrummed per shift during the operation period. Quantifiable levels of Orange Herbicide observed during the assessment period are well correlated with activities at the wharf leading to the conclusion that the M/V Vulcanus was the source of the contamination (see previous discussion in Section 4.1.3.2 above). All concentrations were well below the suggested aquatic life criteria.

It is concluded that concentrations of Orange Herbicide observed by BCL at this site were above background on several occasions during the period July 27 to August 23. There were no impacts on either the human or aquatic population from concentrations after the operation were below quantitation levels.

4.1.3.4 Potable Water (Site P1 [Composite]
or P2 [Grab])

The potable water system on Johnston Island consists of the salt-water intake system, the pumphouse, the distillation plant, the short-term storage tanks and chlorination house, the long-term storage reservoirs, and the distribution system.

The desalination plant operates approximately four days per week. Freshwater is produced at a rate of 5,700 gallons (21,575 liters) per hour. After lime-soda softening, the water is pumped to two storage tanks of 30,000 gallons (113,550 liters) total capacity.

As an additional measure to protect the island drinking water supply, the desalination plant was not operated during or for 24 hours after the second deballasting period at the recommendation of Battelle scientists. During the first deballasting operation, the plant operated for two hours at the end of the deballasting period.

Sixteen samples were obtained by BCL from the temporary storage tanks during the operational period. Concentrations of 2,4-D were never above the detection level of 0.1 ppb while 20 percent of the samples showed trace levels of 2,4,5-T. None of the 2,4,5-T concentrations was above 0.2 ppb. The most stringent water quality standard applicable is the Safe Drinking Water Act for which the maximum levels of 2,4-D are 100 ppb.⁽¹³⁾ Therefore, the concentrations of 2,4-D never exceeded 0.1 percent of this value and those for 2,4,5-T were at or below 0.2

percent of the maximum level of 100 ppb. Long-term allowable concentrations of 4.4 and 35 ppb for 2,4-D and 2,4,5-T, respectively, were not exceeded for even a single sample in the potable water system. The allowable concentration for TCDD in water (for a one percent total body exposure from water) is 3.5×10^{-5} ug/l.⁽³⁷⁾ Even if the TCDD content of the HO in the water was 47 mg/kg, the maximum found in the entire herbicide stock, the maximum concentration in the drinking water supply predicted from the concentration of 2,4-D and 2,4,5-T is at least two orders of magnitude lower than the allowable life time daily intake. The concentration does not allow for the probable further dilution in the long-term storage reservoirs. The one potable water sample analysed for TCDD was non-detectable (minimal detected concentration of 3.61 ng/l).

Data obtained by Battelle are consistent with those generated by the Air Force. The Air Force baseline monitoring detected trace concentrations of 2,4-D in eight samples and trace concentrations of 2,4,5-T in 11 samples. A total of 75 samples were analyzed by the Air Force.

The conclusion regarding the potable water system is that no hazard was present to the inhabitants of the island from this source as ng/l a result of Pacer HO operation.

4.1.3.5 Sewage System (Site SE1 [Composite] or SE2 [Grab])

The sewage system on the island utilizes a series of lift stations to move the wastewater and to minimize dead spots. The volume of sewage was estimated as 75,000 gallons (283,875 liters) per day plus or minus 20 percent.⁽²²⁾

A total of thirteen samples was analyzed during the operational, interim, and postoperational periods. During the dedrumming and transfer operation, the maximum 24-hour average concentration of 2,4-D was 65.63 ppb and the maximum 2,4,5-T concentration was 72.15 ppb. After the operation the concentrations decreased rapidly to near background levels.

A plot of concentrations versus time shows four peaks for each component (Figure 29). Since the discharge of HO to the sewage system should be related to the amount of contaminated laundry, the peak concentration periods should and do correspond to periods of maximum dedrumming activity.

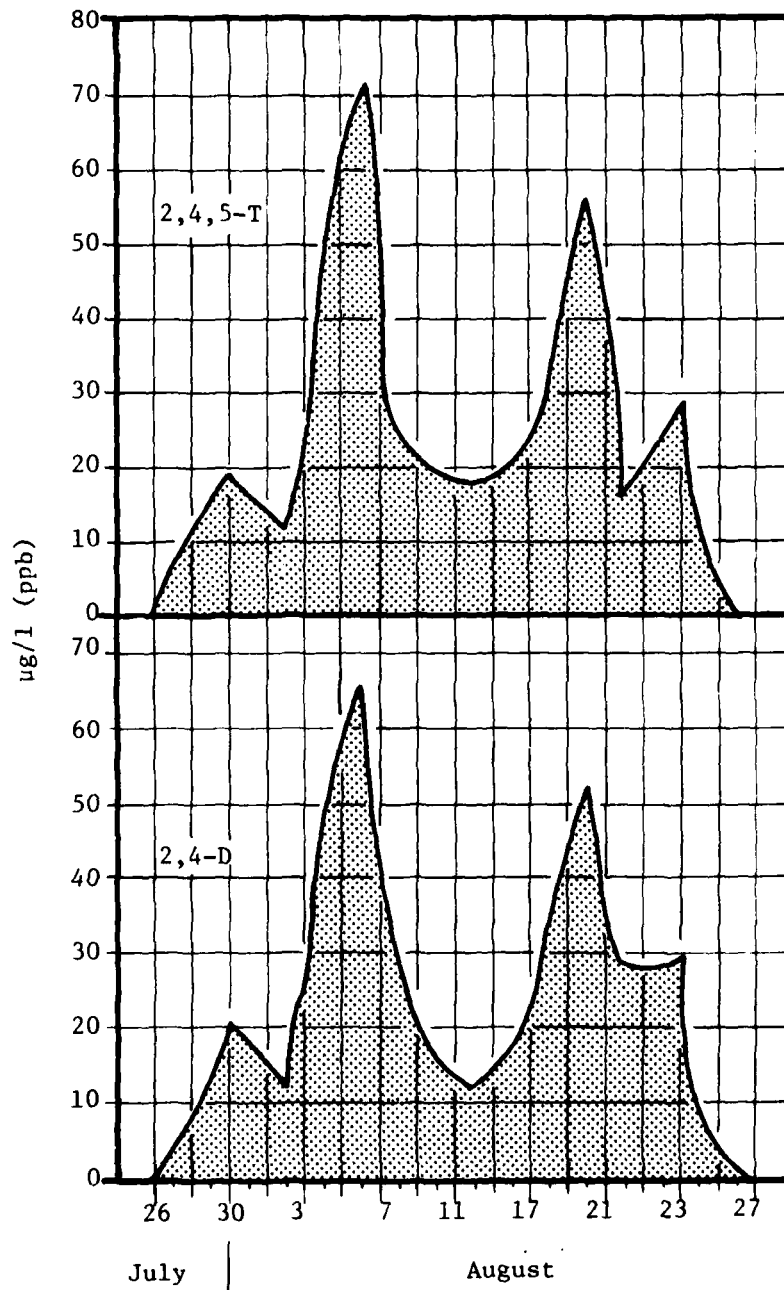

FIGURE 29. SEWAGE SYSTEM DISCHARGES OF 2,4-D AND 2,4,5-T TO THE OFFSHORE AREA SOUTH OF JOHNSTON ISLAND

One grab sample taken at noon on July 29, was analyzed and exhibited 2,4-D concentrations about 10 percent higher than the corresponding 24-hour average. Similarly, the grab sample showed 43 percent higher 2,4,5-T levels than the composite. July 29 was in the peak dedrumming activity period for the first loading operation.

The total mass of Orange Herbicide discharged to the marine environment from the wastewater system can be determined from Figure 29 and the estimate of sewage production. The total mass of 2,4-D released was approximately 0.46 lb (0.21 kg) and the total of 2,4,5-T released was 0.48 lb (0.22 kg). The sum of the two components on a volume basis represents less than 0.1 gallons of pure herbicide.

4.1.3.6 Wastewater Outfall (Site WO)

The pollution field which develops in a receiving water body can be modeled if certain velocity and flow components are known. The area and configuration of the field are functions of the

- Rate of discharge
- Diameter, direction, and submergence of the outfall pipe
- The velocity of receiving water currents.

The dilution effected at the top of a wastewater plume can be determined from the differences in density between the waste and the receiving water, the rate of discharge and the orifice diameter.

At Johnston Island, the sewage outfall consists of a simple, 10 inch (0.25 meter) open-ended, prestressed concrete pipe discharging at 25.6 feet (7.68 meters) from the surface. To calculate the rate of discharge, Q , it was assumed that all sewage flow occurred during the 14 daylight hours. At an estimated 75,000 gpd, the hourly pumpage was 5,367 gallons. Based on observation, the daytime pumping cycle was 5 minutes on, 15 minutes off or 1785 gallons per cycle for an estimated 360 gpm (0.797 cfs) discharge.

The dilution ratio $S = Q_o/Q$. Here Q_o is the volume flow rate of discharge after dilution with the receiving water.

The densimetric Froude number, $F = Q/0.25 \pi d^2 (g'd)^{1/2}$, is used to determine the dilution factor where,

d = Diameter of outfall pipe and $g' = g(\rho_s - \rho/\rho)$ is the apparent acceleration of orifice flow due to differences in density between the wastewater discharge and the receiving water. ρ_s , was taken as 1.025 g/cc for seawater at 26 C while ρ was taken as 0.9944 for freshwater at 34 C, (18) the mean temperature measured at Site SE.

The warmer, less dense freshwater plume should rise through the more dense saline receiving water. The dilution ratio was obtained from Reference 41 where F is plotted as a function of y_0/d and where:

y_0 = depth above the top of the outlet
and d has its former meaning.

It is of interest to examine the relative areas of influence of the sewage and the herbicide. The sewage, having a very low dissolved oxygen content, creates an area in which fish and other higher life forms cannot exist. If it can be shown that this extends to or beyond the similar extent of the toxic herbicide concentrations, then it can reasonably be concluded that the discharge of herbicide has had no incremental impact.

To increase the dissolved oxygen in the sewage (0.9 mg O_2/ℓ) to 5.0 mg/l by a simple mixing with receiving water and ignoring as a first approximation the oxygen demand rate and, oxygen transfer a dilution factor of at least 5.5 is required. A dilution factor for herbicide of about 4 is required assuming conservatively that the maximum peak concentrations reached during any 24-hour period were 50 percent greater than the highest average HO concentrations observed by BCL (0.130 ppm) and that the no-effect level is 50 percent of the lowest 48-hour TL_m (0.100 ppm).

The required dilution for dissolved oxygen at the head of the rising plume is achieved about 5.5 meters below the surface while the Herbicide concentration of 50 ppb is achieved more than 6 meters below the surface. A dilution factor of 30.7 at the surface was calculated so that neither pollutant affects the surface layers of water.

The impact area in the horizontal plane can be calculated in the presence of a steady velocity component, U , in the receiving

water by determining the distance, x , at which the pollutant is dispersed by lateral diffusion to a concentration, c_x , from an initial concentration, c_0 . Four assumptions are required to model the behavior of a conservative pollutant:

- The turbulent diffusion law is applicable
- The eddy diffusivity or turbulent transport coefficient, ϵ , is a function of (Z/Z_0) where Z is the plume width at a distance, x , from the discharge and Z_0 is the width of the discharge at the orifice
- The value of Z/Z_0 is a function of x but not z , and,
- Vertical mixing in the y direction and longitudinal mixing in the x direction is minimal.

Solutions to the resulting differential equations are plotted in Reference 41 as a function of $\beta x/Z_0$ and the dilution factor C_0/C_x , where $\beta = 12\epsilon_0/UZ_0$. Since it is desired to know x , the graphical solutions can be used in reverse solving for x given the required dilution factor. In the analysis ϵ/ϵ_0 is assumed equal to $(Z/Z_0)^{4/3}$, after Brooks. (39)

Two situations were identified for Johnston Island. For Case I (easterly flow), the receiving water current is essentially parallel to the discharge direction and has a speed of 2.5 ft/sec (0.78 m/sec). The calculated value of x is then 774 ft (240 meters) for dissolved oxygen and 539 ft (167 meters) for Orange Herbicide. The area in the xy plane at or near the concentration c_x is approximately a trapezoid whose height is equal to x , whose base width is equal to Z_0 and whose top width equals Z where $Z = Z_0 (1 + 2/3\beta x/Z_0)^{3/2}$. For dissolved oxygen, the impact area is 2,334 ft² (259.3 m²) and for herbicide it is 1170 ft² (130.1 m²).

For Case II (westerly flow) the ambient current is nearly perpendicular to the discharge. As a first approximation, it is assumed that the velocity component perpendicular to the flow does not affect the dilution factor. The parallel velocity component is about 16 percent of the total (about 10°) or 0.4 ft/sec. The calculated value of x is then 124 ft (38.5 m) for dissolved oxygen and 86.5 ft (26.8 meters) for herbicide. The impact areas are 373.5 ft² (41.5 m²) and 1,875 ft² (20.8 m²), respectively.

In both cases, it is seen that the effects of low dissolved oxygen in the sewage are more serious than those from Orange Herbicide. Furthermore, the intermittent nature of the discharge (5 minutes of every 20) prevents a steady-state concentration from being achieved for very long, if at all.

None of the samples taken by BCL showed more than a trace of herbicide, attesting to the rapid dissipation of the herbicide in the receiving water body. It is concluded that the effects of this discharge were negligible.

4.1.3.7 TCDD

Water samples were sent by BCL to the Air Force for TCDD analysis by another contractor. As of this writing, a total of 11 samples from all sites had been analyzed. No TCDD was found in any sample. Minimum detectable limits ranged from 3.6 to 8.0 nanograms per liter.

4.1.4 Biota

The environmental impact of the H0 land-based disposal operations upon the biotic portion of the natural environment of Johnston Atoll was evaluated with particular emphasis upon the vegetation of Johnston Island and the bird population of Sand Island.

4.1.4.1 Vegetation

The vegetation of Johnston Island as observed at the start of the operation can best be described as sparse, primarily because of the poor soil and climatic conditions found there. Only in areas where residents fertilize and water regularly was the vegetation in a healthy, rapidly growing state. The prominent species in the open areas of Johnston Island (or more specifically the man-made portion), were Fimbristylis cymosa, Lepturus repens and Pluchea carolinensis. The first two species

were also prominent in the area immediately adjacent to the HO storage yard and dedrumming facility, occurring both upwind and downwind of this area. The vegetation occurring downwind consisted of only three species, Lepturus repens, Fimbristylis cymosa and Conyza bonariensis which occurred only in areas not disturbed by vehicular traffic (Plate 19).

Orange Herbicide is a 50:50 mixture of two phenoxy herbicides, 2,4-D and 2,4,5-T which are chemicals widely used to kill dicotyledonous weed species. Therefore, broadleaf vegetation was expected to be most susceptible to impact from the HO disposal operations. Because of their greater sensitivity to these two phenoxy herbicides, any dicotyledonous species in the area adjacent to the dedrumming facility, or perhaps adjacent to the areas where transport and transfer operations occurred, would be most susceptible to herbicide damage. Accordingly, four areas were chosen as the primary sites where vegetation would be examined on a weekly basis for signs of herbicide damage. These sites were (1) the dedrumming area, (2) along the roadway between the dedrumming facility and the main wharf, (3) the swimming pool and (4) the U.S. weather station. The major plants and especially the dicotyledonous plants, in these four areas were examined for symptoms of epinastic growth. A list of these species appear in Table 13.

No signs of epinastic growth were noted during the preoperational vegetation survey made on July 27. There were several Casuarina equisetifolia trees along the roadway adjacent to and upwind from the dedrumming facility which did not appear healthy, having fewer "needles" in comparison with other trees of the same species. There were, however, several trees of this species at the opposite end of the island in the area of the baseball field which were also very thin.

The vegetation surveys which were conducted during the dedrumming operation revealed only one instance of herbicide injury. In this instance one Conyza bonariensis plant (Plate 20) from a total of about 10 located downwind of the dedrumming area showed the classic symptoms of epinastic growth. However, it is not known whether this HO injury was a result of the land-based HO disposal operations or whether it occurred prior to the start of the operation. In any event, this injury observed on one plant of one species is not a significant impact of the land-based HO disposal operation on the vegetation of Johnston Island.

TABLE 13. PLANT SPECIES OBSERVED ON JOHNSTON ATOLL

<u>Calatropis</u> <u>gigantera</u>	
<u>Elusine</u> <u>indica</u>	Goose Grass
<u>Euphorbia</u> <u>hirta</u>	Spurge
<u>Fimbristylis</u> <u>cymosa</u>	
<u>Euphorbia</u> <u>prostrata</u>	Spurge
<u>Tridox</u> <u>procumbens</u>	
<u>Portulaca</u> <u>oleracea</u>	Purslane
<u>Pluchea</u> <u>carolinensis</u>	
<u>Musa</u> <u>sapientum</u>	
<u>Casaurina</u> <u>equisitifolia</u>	Ironwood
<u>Heliotropium</u> <u>ovalifolium</u>	
<u>Cyperus</u> <u>rotundus</u>	Purple Nutsedge
<u>Coccoloba</u> <u>uvifera</u>	Sea Grape
<u>Ipomoea</u> <u>pes-caprae</u>	Beach Morning Glory
<u>Cocos</u> <u>nucifera</u>	Coconut Palm
<u>Sesuvium</u> <u>portulacastrum</u>	
<u>Scaevola</u> <u>taccada</u>	
<u>Hibiscus</u> <u>rosa</u>	
<u>Cynodon</u> <u>dactylon</u>	Bermuda Grass
<u>Lepturus</u> <u>repens</u>	Bunch Grass
<u>Solanum</u> <u>melogena</u>	Eggplant
<u>Solanum</u> <u>lycopersicum</u>	Tomato
<u>Capsicum</u> <u>frutescens</u>	Pepper
<u>Plumeria</u> <u>rubra</u>	
<u>Conocarpus</u> <u>erecta</u>	
<u>Cenchrus</u> <u>echinatus</u>	Sandbur
<u>Nerium</u> <u>oleander</u>	Oleander

The postoperational survey conducted on August 27, revealed no additional instances of epinastic growth. The vegetation of Johnston Island as well as that of the other three islands appeared not to be affected by the land-based HO disposal operations.

4.1.4.2 Birds

Except for man, birds and particularly sea birds, are ecologically the most important species on the four islands of Johnston Atoll. The original (eastern portion) of Sand Island is of major importance for its breeding population of Sooty Terns and of significant importance for breeding populations of Red-footed Boobies, Brown Noddies, Wedge-tailed Shearwaters and Great Frigatebirds. It is also significant as a wintering area for shorebirds, particularly the American Golden Plover and Ruddy Turnstone.

The sea bird population of Sand Island as observed at the start of the operation was found to be quite similar to previous descriptions with respect to the species observed, the nesting areas of each species and the stage in the breeding cycle of each species which was observed. ⁽²⁾ No attempt was made to monitor the numbers of each species present on Sand Island. Instead the weekly inspections were aimed at detecting abnormalities within behavior, distribution and mortality which might be indicative of an adverse impact of the HO disposal operations upon the sea bird population of Sand Island.

The preoperational bird survey of Sand Island conducted on July 26, revealed the bird population to be healthy except for a few individuals of several species which had sustained wing injuries as a result of striking guywires. There were numerous dead birds which were observed in various stages of decay. Dead birds in less advanced stages of decay were examined and broken wings and subsequent starvation was believed to be the major cause of death. A further indication of the general good health of the population was the fact that many very young chicks were observed, notably those of the Brown Noddy.

During the initial survey, and subsequent ones a total of 11 species was observed on Johnston Atoll (Table 14). Of these 11 species, seven comprised the breeding population of Sand Island. The distribution of six species on the original portion of Sand Island is shown in Figure 30. Brown Noddy, the most dominant of the six species, nested over most of the island particularly along the perimeter of the island. Many Brown Noddies could be seen either sitting on eggs or with very young chicks. Sooty Tern the second most dominant species, nested in a rather confined area southeast of the Loran antenna. Wedge-tailed Shearwater nested in burrows along both sides of the road leading to the antenna. Frigatebirds were limited to the southern shore and the southwest islet. Brown boobies were found on the hillside south and east of the antenna. Red-footed Boobies were found nesting on the Tournefortia bush northeast of the antenna. They could also be seen on the guywires northeast and southeast of the antenna. A seventh species of sea bird, Red-tailed tropicbird, was found nesting under low vegetation on the man-made portion of Sand Island. Several chicks of this species were seen at various stages of maturity.

During subsequent bird surveys conducted on August 1, 8, 15 and 22, while the H0 disposal operation was proceeding or the postoperational bird survey of August 27, no abnormalities in behavior, distribution or incidence of dead birds were seen in the sea bird population of Sand Island or the avifaunal population of the other three islands of the Atoll.

4.2 Human Environment

4.2.1 Industrial Hygiene

In addition to the air monitoring program established inside the dedrumming facility, a comprehensive operations report including all accidents and injuries regardless of severity was compiled daily for each shift. In view of these reports, general observations of operational procedures, and concentrations of herbicide detected in the air of the working environment, the disposal program in effect on Johnston Island was reasonably safe. Problems associated with disposal operations were of a minor nature. Following is a summary of the industrial hygiene monitoring activities.

TABLE 14. BIRD SPECIES OBSERVED ON JOHNSTON ATOLL

<u>Scientific Name</u>	<u>Common Name</u>
<u>Anous stolidus</u>	Brown Noddy
<u>Sterna fuscata</u>	Sooty Tern
<u>Gygis alba</u>	White Tern
<u>Arenaria interpres</u>	Ruddy Turnstone
<u>Pluvialis dominica</u>	American Golden Plover
<u>Fregata minor</u>	Great Frigatebird
<u>Sula sula</u>	Red-footed Booby
<u>Sula leucogaster</u>	Brown Booby
<u>Phaethon rubricauda</u>	Red-tailed Tropicbird
<u>Phaethon lepturus</u>	White-tailed Tropicbird
<u>Puffinus pacificus</u>	Wedge-tailed Shearwater

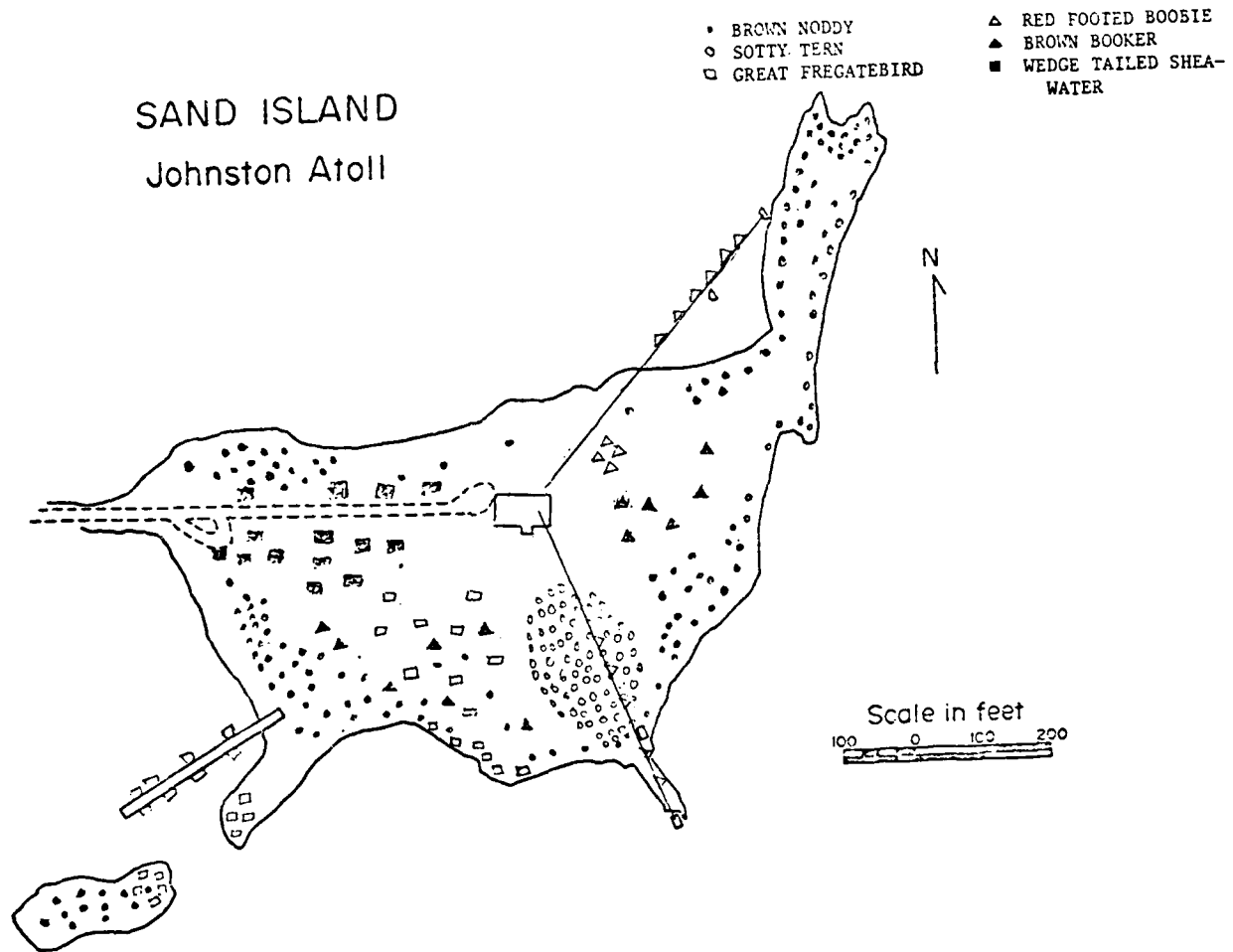

FIGURE 30. THE DISTRIBUTION OF SIX SEABIRD SPECIES ON THE ORIGINAL PORTION OF SAND ISLAND, JOHNSTON ATOLL, 1977

4.2.1.1 Industrial Hygiene Air Monitoring

The sampling of personnel breathing zones inside the dedrumming facility provided an accurate means of investigating individual exposures (see Section 3.2.3.1.). A total of nine areas inside the facility were differentiated in the personnel sampling code in order to determine the effects of different working assignments on herbicide exposure. These areas included the high (opening) and low (draining) positions on either side of the barrel rack for the four corner stations inside the facility, and also the pump operator.

Figure 19 presents the locations within the facility for personnel monitoring and their alphameric designations. Summary results for these locations are presented in Table 15. It is generally not possible to differentiate among the results, except that these breathing zone exposures are generally higher than at the fixed monitors at the edge of the facility.

This may be due to the mobility of personnel from one working position to another during a shift. Thus, monitored concentrations were representative of individual exposure, and not position exposure.

In exception to this, the pump operator usually stayed to the eastern (upwind) end of the facility. The five samples taken at this position show little difference from what was recorded for other personnel. The operator's close proximity to the herbicide sump beneath the pump may account for this.

The results of the personnel samples taken inside the dedrumming facility indicate levels of Orange Herbicide far below the Threshold Limit Value (TLV) of 10 milligrams per cubic meter established by the American Conference of Governmental Industrial Hygienists. Concentrations ranged from 2.71 micrograms per cubic meter to 62.81 micrograms per cubic meter, with a mean of 30.66 and standard deviation of 13.71.* Levels were slightly higher during the second loading of the ship as compared to the first. This may be due to increased contamination of protective equipment near the breathing zone (splash aprons, face shields, and respirators) as well as

* A statistical examination could not demonstrate with any confidence that any one location was different than the others. Therefore, the locations were grouped for averaging.

TABLE 15. SUMMARY TABLE OF AIR CONCENTRATIONS-
PERSONNEL SAMPLERS

Site	Interval	No. of Samples	2,4,5-T Mean	2,4,5-T Stand. Dev.	2,4-D Mean	2,4-D Stand. Dev.	* Percent Below Quantitative Detection Limit	
							2,4,5-T	2,4-D
FP (Pump operator)	First load	5	6.32	3.61	14.36	8.18	0	0
	Second load	0	--	--	--	--	--	--
PX Outside rack	First load	2	8.48	0.20	17.40	2.34	0	0
	Second load	7	12.80	6.48	22.86	10.94	0	0
PV Inside rack	First load	2	7.86	0.83	16.17	0.95	0	0
	Second load	2	9.45	0.89	16.38	0.02	0	0
PU Inside rack	First load	5	8.64	3.14	17.86	6.90	0	0
	Second load	5	15.37	5.28	25.71	8.83	0	0
PT Outside rack	First load	5	7.30	4.43	15.55	8.48	0	0
	Second load	3	14.01	8.44	24.65	14.94	0	0
PY Outside rack	First load	0	--	--	--	--	--	--
	Second load	1	6.76	0	13.24	0	0	0
PZ Inside rack	First load	2	13.30	0.42	25.35	0.92	0	0
	Second load	0	--	--	--	--	--	--
PQ Inside rack	First load	1	9.90	0	19.40	0	0	0
	Second load	0	--	--	--	--	--	--
PR Outside rack	First load	1	16.10	0	30.80	0	0	0
	Second load	2	13.39	2.79	22.87	2.96	0	0

* All samples (either trace or non-detect) that were below the quantitative detection limit were taken to be zero for the calculations above.
(All concentrations are in micrograms per cubic meter).

the dedrumming area in general. It is interesting to note that in all of the personnel samples the 2,4-D component exceeded the 2,4,5-T component by a ratio of about two to one. The increased volatility of the lower molecular weight 2,4-D accounts for this.

TCDD analyses from the benzene impinger at the southwest corner of the dedrumming facility were conducted by another contractor. No TCDD was detected in any of the samples analyzed. Minimum detectable concentrations ranged from 6.6 to 23.4 nanograms per cubic meter.

4.2.1.2 Accidents or Injuries

Very few accidents or injuries occurred as a result of the operations on Johnston Island. The following is a list of reported occurrences, all of them being minor in nature:

- Dust in eye of worker near drum crusher
- Herbicide in eye--three occurrences
- Nail puncture wound
- Workman slipped inside facility--two occurrences
- Groin injury from handle of floor brush
- Finger pinched between two drums.

In addition to the above list, ailments not necessarily related to operational activities included a workman with back pain (reported to dispensary during off-duty hours) and another with a cold with elevated temperature.

The problem of dust emanating from the crusher was resolved by the issuance of face shields to workers in that area. The cases of herbicide in the eye were immediately treated and affected workers were able to return to work. In some cases a pressure buildup inside the drum caused a spray to be released as the barrel was being opened from the top, a position frequently just below the workers breathing zone. Slippery floors within the dedrumming facility continued to be a problem despite the use of a cleaning solvent.

4.2.1.3 Miscellaneous

Several miscellaneous activities having potential implications for the industrial hygiene monitoring included the following:

- The heavy forklift and refueler traffic in the dedrumming area posed no ambient dust problem. The island's crushed coral composition accounts for this.
- The fact that the dedrumming facility was left open to prevailing trade winds allowed exposures of the herbicide to workmen to be minimized. This ventilation system also provided an excellent means of cooling the workmen, who were at the same time shaded from the intense afternoon sunshine.
- The effectiveness of the respirators was questioned by many of the workers. The replacement of filter cartridges in some cases failed to prevent herbicide odors from being experienced. The major problem was an improper and often uncomfortable fit around the face. Although the wearing of face masks in the dedrum facility were mandatory throughout the operations, violations of this policy were frequently noted.
- Some personnel were observed carrying smoking materials into the dedrumming facility. This practice can be dangerous because of the excellent absorbing tendencies of tobacco. Some workers were seen smoking only a few feet outside the facility in the area of the R-5 refuelers. The incident was immediately reported and the crews advised, whereupon the practice ceased.
- The impact of the disposal operation on regular island personnel caused no problems of significance. Housing and mess hall personnel were asked to work longer hours to accommodate those project personnel working on the island temporarily. The area from the wharf to the dedrumming area bounded by the sea to the north and the taxiway (R-5 access road) to the south was also placed off-limits to all personnel not directly involved with the project.

4.3 Non-HO Impacts

4.3.1 Temperature and Dissolved Oxygen

Non-HO water quality parameters monitored during the project included temperature and dissolved oxygen. Tables 16 and 17 are statistical summaries of these data. For each of the five locations monitored on a regular basis, the mean, standard deviation, and number of samples are given. No statistically significant differences between the baseline and operational or postoperational periods were noted.

Other non-HO impacts can only be described subjectively. These include increases in turbidity and discharges of oil and grease.

Turbidity plumes associated with the ship's deballasting operation were noted during both loading periods. These were composed primarily of water with suspended rust particles and dirt from the bilge. The compensation point for photosynthesis was certainly reduced by more than 10 percent. However, the area affected was between the hull of the ship and the wharf and was shaded by the ship. It is doubtful that this area is of high ecological value due to the extensive alteration of the substrate for construction and dredging in previous years. The turbidity created by the deballasting activities created no observable impact on the fish population observed swimming in the edges of the plume.

Small diesel fuel slicks or sheens were noted in the deballast discharge and in the exhaust from the landing craft used to obtain water samples. These were small enough and/or were spread over a large enough area to not cause the dissolved oxygen to fall below 5.0 mg/l or to have caused toxic effects. The latter comment is based solely on observational evidence and on the high probability of rapid evaporation of the aromatic fractions which are the most toxic.

4.3.2 Operational Impacts

The most significant non-HO impact associated with the project is that of incremental air transportation, and its associated fuel consumption and effluents. It is estimated that the operation itself required about

TABLE 16. STATISTICAL SUMMARY OF NON-HO WATER DATA

Location		Baseline		Operational Interim				Post-Operational	
		Temp.	D.O.	Temp.	D.O.	Temp.	D.O.	Temp.	D.O.
Wharf	\bar{x}	26.8	7.3	27.2	6.8	26.6	6.8	27.6	6.9
	s	1.8	0.4	1.0	0.4	1.7	0.4	0.6	0.2
	n	23.	24	79	83	24	24	18	18
Saltwater Intake	\bar{x}	26.1	7.7	26.9	7.0	26.6	7.1	27.3	7.1
	s	0.6	0.3	0.9	0.4	1.5	0.4	0.6	0.2
	n	24	24	89	89	24	24	18	18
Potable Water (Composite) only	\bar{x}	32.0	6.0	33.7	5.5	33.8	5.9	33.0	5.1
	D	1.7	0.3	1.1	0.4	2.0	1.1	1.0	0.2
	n	3	3	16	16	3	3	3	3
Sewage (Composite) only	\bar{x}	32.5	1.1	33.9	0.9	32.8	1.1	33.8	0.8
	s	2.1	0.2	1.1	0.4	1.3	1.1	0.8	0.4
	n	2	2	16	16	6	6	3	3
Waste Outfall	\bar{x}	26.4	6.9	27.3	6.6	--	--	27.5	6.7
	s	0.5	0.4	1.6	0.5	--	--	0.7	0.2
	n	6	6	13	13	0	0	2	2

Temp. in °C and D.O. in mg/l.

TABLE 17. PERCENT DISSOLVED OXYGEN SATURATION FOR MEAN TEMPERATURE

	Baseline	Operational	Interim	Post-Operational
Wharf ^(a)	106	99	99	101
Saltwater intake ^(a)	108	101	103	103
Potable water	81	76	82	70
Sewage	15	13	15	11
Waste outfall ^(a)	99	96	--	99

(a) Assumed chloride concentration of 15 ppt.

100 round trips to Johnston Island, and several pallet loads of air freight, all carried on scheduled air carriers. In addition, a special military flight was sent from Johnston Island to Wright-Patterson to carry samples for TCDD analysis.

4.3.3 Land-Based Incineration of Wood Dunnage

After the Battelle land based environmental monitoring program had concluded, U.S. EPA and U.S. ERDA agreed to permit the burning of wood dunnage on Johnston Island. This dunnage had been contaminated by leaking Orange Herbicide drums. Visual inspection of the wood indicated that less than a third of the wood was contaminated with the H0 and was in a dry kindling state. It was estimated by the Holmes and Narver engineers that the dunnage totalled 300 cubic yards.

Air Force scientists and engineers on the island designed a temporary, but substantial, incinerator to dispose of the dunnage, plus lab aprons, gloves, tissues and a drum of solvents used to clean glassware (Plate 22). This incinerator was designed to collect the 10-15 knot trade winds common and constant on the extreme northwestern tip of the island. The winds were constricted and made more turbulent by funneling over baffling blocks that were placed into the air flow under the hearth or primary chambers of the incinerator. A steel plate was placed over this charging chamber to intensify the combustion temperatures and to increase the retention time in the chamber as the exhaust gases traversed the glowing steel plate into stack boxes in the rear of the incinerator. Twin stacks were designed to permit sufficient air flow rates and to enhance the draw and to reduce the potential of a snuffing or a temporary flame out during a charging operation. The effective height of the exhaust plume before dispersing in the trade winds was designed for approximately 20 feet of vertical rise before horizontal displacement and dispersion began.

The incinerator was located in an ideal, tip of the island at a downwind location. A meteorological station was located nearby to the incinerator. This facility was used to record wind speed and direction

data. Battelle's analytical laboratory staff reported that the fire during the first 20 minutes permitted some gray particulate matter to emit. After the initial ignition the plume was reported to diminish to a light gray-white exhaust stream as the combustion temperature increased (Plate 23).

Due to the reported twisting and sagging of the steel incinerator roof plates, it is estimated that the temperatures were as high as 2500 F. The fire was continually batch loaded to maintain the temperature in the block and steel incinerator chamber.

The Air Force scientists placed high volume air particulate samplers in the near geographic area of the incinerator and the results are shown in Table 18. Hi-volume samplers ran for 3 hrs at indicated flow (nominal) rates.

TABLE 18. AIR FORCE HI-VOLUME SAMPLER RESULTS OF HO DUNNAGE BURN, SEPTEMBER 10, 1977

Sample Code No.	Location	2,4-D ng/m ³	2,4,5-T ng/m ³	Sampled Air m ³
SDW 09577	Outside Analytical Laboratory Bldg. 6	11.6*	11.3*	214
SDW 09577	100 yards downwind on beach terrace	8.5*	11.1*	178
SDW 09577	100 yards downwind on beach terrace	87.3	174.6	280

*These are within the range of normal background values for unextracted filter paper used with the hi-volume samplers.

The detection limit for 2,4-D and 2,4,5-T was 0.1 µg/sample. As can be seen by the data the concentrations of 2,4-D and 2,4,5-T associated with particulates are extremely low and such loadings should not have adversely impacted the seas west of Johnston Island.

The ash value suggests that the burn was successful in combusting the HO in the wood dunnage.

4.3.4 Social and Economic Impact

It was anticipated that the influx of the disposal staff might cause some dislocations with the island staff, due to competition for limited recreational facilities. This was not observed.

5. RELATIONSHIP BETWEEN LOCAL SHORT TERM USES
OF JOHNSTON ISLAND TO LONG TERM IMPACTS

Had the US Air Force been unable to implement the at-sea incineration disposal action, other disposal methods and/or recontainerizing of the stored HO would have been necessary. Such alternative actions would have been implemented as a matter of Air Force environmental protection policy. The following discussion delineates the long term environmental impacts resulting from completion of the HO disposal operations.

5.1 Air

The removal of HO resulted in air emissions and, thus, detectable air concentrations of 2,4-D and 2,4,5-T at several sites. The most predominantly affected area was that of the drum storage yard where local concentrations were as high as 30-40 ug/m³. In addition, smaller concentrations were measured at the wharf site, at the meteorological station, and in the change room. Furthermore, the tomato plants delineated a plume of HO vapors downwind of the drum storage yard. All of these concentrations, except downwind of the drum storage yard, were transient in nature with significant decreases observed when dedrumming operations ceased. The concentrations downwind of the barrel yard are expected to decrease with time as the HO contaminated soil weathers.

5.2 Water

Orange Herbicide dedrumming and transfer operations resulted in measurable short term concentrations of 2,4-D and 2,4,5-T at the wharf,

saltwater intake, and in the sewage effluent. The highest concentrations were associated with the deballasting of the M/V Vulcanus and on at least one occasion resulted in herbicide concentrations in excess of recommended aquatic life criteria. All of the observed concentrations were transient. The thermal destruction of the herbicide stocks created conditions for the eventual return of the water environment to its prior state.

5.3 Land

Very little land in addition to the storage area was used for disposal purposes. Rather, approximately 120,000 square meters of land were evacuated of drums and, after reclamation, will be available for other uses.

A small part of the drumyard was used for storage of the crushed drums. The crushed drums have been removed from the island for recycling.

5.4 Biota

No adverse impacts on the biota of Johnston Atoll were noted as a result of the disposal operations. It is possible that, had the disposal operation not been completed, an accident of some kind may have caused the release of hazardous quantities of herbicide from the drum storage yard into the ecosystem of the Atoll.

5.5 Summary

The short term use of Johnston Island made use of existing facilities and equipment, and the largest impact was that of an accelerated release of HO into the Atoll environment. No consequences of that release, which was minimal, were observable or expected.

This impact must be compared to the alternative of no action. Had the at-sea or an alternative disposal operation not been conducted, the drums containing the HO could have continued to leak into the Atoll environment. Battelle estimates that about 6250 lbs of HO were released into the environment (mostly through volatilization) during the dedrumming activities. In comparison, drum leakage was causing as much as 49,000 lbs of HO to escape to the environmental each year.

6. MEASURES TO MITIGATE ENVIRONMENTAL IMPACTS

Since the whole thrust of project Pacer HO was to eliminate the stocks of HO in an environmentally safe manner, this section is somewhat redundant. Basically, the efforts to mitigate adverse environmental impacts of the land based operation occurred in several areas.

6.1 Drum Yard

The dedrumming crew was alerted to notice the existence of leaking drums. Fresh leakers were pulled out and dedrummed immediately. Where fresh spillage was noted, it was sorbed and surface soil was scraped and sealed.

6.2 Dedrumming Facility

The floors of the facility were frequently mopped with a solvent to prevent a buildup of HO on the concrete floor, and subsequent tracking into the barrel yard.

6.3 Change Building

The use of boots at the site and the use of the showers in the change facility prevented the spread of the HO over the island by the dedrumming crew. All the buses and the cleanup facility used by the dedrumming crew were decontaminated after the project.

6.4 HO Transfer

From the dedrumming facility, the HO was transferred into R-5 refuelers, transported to the ship, and pumped into the ship. At both transfer points, zero volume connectors and catchment basins avoided

any spillage of HO. The pump at the dockside was located with a plastic lined sump constructed of sandbags, in case of catastrophic pump failure. The equipment was kept at the wharf in case of fires. The refueler pumps were bypassed to avoid contamination and deterioration of pump seals. Finally, the road used by the R-5's, the wharf, and the drum yard were closed to non-Pacer HO project personnel.

6.5 Cleanup

At the end of the project, all of the equipment, starting at the dedrumming facility, was flushed with diesel fuel, which was then loaded on the M/V Vulcanus. Thus, the island was left nearly clean of HO.

6.6 Site Reclamation

A monitoring program has been instituted by the Air Force to track the degradation of HO residue in the coral soil of the drumyard. Through time, it is anticipated that evapo-transpiration, weathering, and microbial action will work to reduce HO levels to biologically and ecologically safe levels. This program will monitor soil concentration until such levels are reached.

This monitoring program is in response to the leakage of drums over the years, and not to the minimal soil contamination which occurred as a result of Pacer HO.

7. UNAVOIDABLE ADVERSE ENVIRONMENTAL DEFECTS

The operations at Johnston Island were remarkable in that no acute impacts of H₂O releases from operations were noted, nor were concentrations high enough to produce observable ecological stresses. This section is presented to discuss those features of the operations which produced unavoidable effects on the air or water of Johnston Island.

7.1 Air

By far the largest release of H₂O occurred to the atmosphere. This was due to the large surface area of exposed H₂O, both within the dedrumming facility and in leak areas in the barrel yards. Battelle has estimated the total quantity released to the atmosphere to be around 6,000 lbs. Since much of this was from fresh exposure of old leakage and from crushing drums, the release was unavoidable.

7.2 Water

Approximately four-hundred and thirty grams of H₂O were discharged through the sewage system to the open ocean as an unavoidable consequence of the need to wash work clothing.

7.3 Land

The operations to remove H₂O from Johnston Island produced almost no spillage to land areas. Only the soil immediately surrounding the crusher and dedrum facilities were slightly and unavoidably contaminated.

8. SUMMARY AND CONCLUSIONS

8.1 General Summary

The disposal operations of dedrumming, hauling, and transferring the Orange Herbicide to the M/V Vulcanus had negligible impact upon the local marine and surface terrestrial environment of Johnston Island. This observation is specific to the herbicide disposal operations of July 27 through August 24, 1977.

8.2 Weather Observations

Weather conditions were such that the wind was consistently from the east at significant velocities (10 to 20 knots). With the dedrumming activities located on the west and north corner of the island, and the ship on the north side, the prevailing air currents carried released herbicide rapidly away from the atoll without exposing the biota on Johnston Island or on the three other islands of the atoll, which lie to the east.

8.3 Ambient Air Observations

In order to determine the impact of dedrumming and transfer operations on the air environment, four monitoring areas were chosen for sampling. These were the meteorology building (located 2 miles upwind for use as a background station), the wharf (300 feet downwind of the loading area), the dedrum facility (to determine occupational exposures), and as an absorbing medium were located at each site for the detection of TCDD. Chromosorb samples were also taken at each site for immediate analysis for 2,4-D and 2,4,5-T. The benzene samples were analyzed at Wright State University. No TCDD was detected in any analyzed samples. The chromosorb samples taken over the duration of dedrumming and transfer operations yielded the following observations:

- Concentrations in samples taken at the upwind meteorology building ranged from levels below detection to trace amounts (less than 1 microgram per cubic meter).
- There was little difference between data recorded at the meteorology building and that at the wharf. The impact on air due to the loading procedure at the wharf was negligible.
- Total herbicide* concentrations detected 310 feet downwind of the dedrum site ranged from 3 to 23 micrograms per cubic meter. Concentrations inside the dedrum facility were only slightly higher, from 7 to 27 micrograms per cubic meter. These concentrations produced negligible impacts.

8.4 Water Quality Observations

Six water sampling locations were utilized for environmental impact assessment throughout the operation. Four of these sampling sites were located immediately offshore of significant land-based activities. The location and analytical results of these sites are briefly summarized here. Levels of herbicide in water samples were generally at or below detectable limits. Of those samples analyzed for TCDD, none were found to contain any TCDD or trace of TCDD.

8.4.1 Saltwater Intake

The water in the vicinity of the intake for the desalination plant was monitored on a daily basis. The level of herbicide ranged from below detection limits (.1 ppb) to 3.43 ppb*. Over 60 percent of the samples analyzed had concentrations below the quantification limit of the analytical method 0.2 ppb. The measured concentrations, including the maximum observed concentration, were well below the applicable standards for human consumption or aquatic life propagation.

8.4.2 Potable Water

Samples taken before the operation showed no detectable concentrations. During the operation, herbicide concentrations* were found at

* Concentration is reported as sum of 2,4-D and 2,4,5-T.

or below trace levels (below 0.2 ppb) in 100 percent of the samples. Measured concentrations were insignificant in comparison with current drinking water standards of 100 ppb.

8.4.3 Sewage Outfall

Water samples were taken on alternating days in proximity to the sewage outfall, which is approximately 550 feet offshore. Only trace levels of either 2,4-D or 2,4,5-T (less than 0.1 to 0.2 ppb) were detected in the samples analyzed. This was of no significance to the aquatic life because the area of adverse impact due to the sewage itself was larger than that of the herbicide.

8.4.4 Raw Sewage

The sewage samples, contaminated from the washing of work clothes showed concentrations of herbicide of from 20.7 ppb to 137.8 ppb*. A total of 0.94 lbs of herbicide was released into the sewage system. The effects of this release, if any, were mitigated by the intermittent nature of the discharge and by the dispersing effect of the currents.

8.4.5 Dedrum

Water samples were taken offshore and downwind of the dedrum facility four times during the operation. One sample contained trace levels of 2,4,5-T while all other samples analyzed had no detectable levels. These concentrations were insignificant.

8.4.6 Wharf

Water samples were taken on a daily basis in the vicinity of the wharf, which included special grab samples during the two deballasting periods

* Concentration reported as sum of 2,4-D and 2,4,5-T.

from the M/V Vulcanus. The water in the immediate vicinity (10 feet) of the deballast discharge contained levels of herbicide* that ranged from below detection to 8,116.7 ppb. The concentrations of HO in the composited water samples at the wharf in the days following the deballasting substantiated an effective dilution process. The concentrations of herbicide dropped from 8,116.7 to 1.90 to 0.75 ppb in the 2 days following the second deballast period. Including the deballasting periods, the concentrations of both 2,4-D and 2,4,5-T stayed below 0.2 ppb (trace) in over 50 percent of the samples taken. Although some concentrations exceeded the upper water quality criterion of 5 ppm by a significant margin, the concentrations were transient and no acute toxic symptoms were noted.

8.5 Biological Observations

8.5.1 Tomato Plant Bioassay

Three days of preoperational observations indicated that concentrations of Orange Herbicide sufficient to cause injury to tomato plants (Lycopersicon esculentum), a species sensitive to herbicide at the low parts per trillion level, only at two of 14 stations. These two stations were approximately 500 feet from the dedrumming site and directly downwind. During the operation, these two stations experienced the most frequent and most severe injury. Occasional damage was experienced at two peripherally located downwind stations.

8.5.2 Vegetation Survey

During this study, no significant physical or morphological changes were noted in any indigenous plant species on Johnston Island which could be attributed to the effects of Orange Herbicide.

* Concentration reported as sum of 2,4-D and 2,4,5-T.

8.5.3 Bird Survey

Observations were made of the bird population on Sand Island both before and during the operation. These observations indicated that there were no effects upon the bird population which could be attributed to the Orange Herbicide disposal operations.

8.6 Industrial Hygiene Observations

The analytical results on air samples for Orange Herbicide (2,4-D and 2,4,5-T) show that personnel exposures were two to three orders of magnitude below the TLV for the acid (10 mg/cubic meter).

The Holmes and Narver, Inc. log of injuries is in agreement with the Air Force record on potentially significant injuries as follows:

- HO in eye - 2
- Cut finger - picket knife - 1
- Slip while cleaning dedrum area - 2
- Finger caught between empty drums - 1
- Walked into brush handle (groin) - 1.

There was one dermatitis case diagnosed as nonoccupational.

Literature Cited

- (1) Amerson, A. B., Jr. 1973. Ecological Baseline Survey of Johnston Atoll, Central Pacific Ocean, Smithsonian Institution, Washington, D.C., (USAF Contract F-44620-67-C-0063).
- (2) Amerson, A. B., Jr. and P. C. Shelton 1975. The Natural History of Johnston Atoll, Central Pacific Ocean, Smithsonian Institution, Washington, D.C.
- (3) Emery, K. O. 1955. Transportation of Rocks by Driftwood, J. Sedimentary Petrology, 25:51.
- (4) Kroenke, L. W. and G. P. Wollard. 1965. Gravelly Investigations on the Leeward Islands of the Hawaiian Ridge and Johnston Island, Pacific Science 19:361-366.
- (5) Christiansen, H. E., et al. 1976 Registry of Toxic Effects of Chemical Substances, Public Health Service, U.S. DHEW.
- (6) Thorp, T. E. 1960. Johnston Island, A Library Brochure, prepared for the Pacific Missile Range, Dept. Geog., Univ. Calif., Riverside.
- (7) Navy Hydrographic Office. 1959. Johnston Island and Reef. H.O. Chart 5356, U.S. Navy, Washington, F.C.
- (8) Wennekins, M. P. 1969. Johnston Island Regional Oceanography, Section 6, Office of Naval Research, San Francisco, CA.
- (9) Kopenski, R. P. and M. P. Wennekins. 1966. Circulation Patterns (near) Johnston Atoll, Winter-Summer, 1965. Office of Naval Research, Spec. Publication 93:1-240.
- (10) Cummings, C., Maj. USAF. 1977. Personal communication to B. Vigon, Battelle Columbus Laboratories.
- (11) Seckel, G. R. 1962. Atlas of the Oceanographic Climate of the Hawaiian Islands Region. Fishery Bulletin 193:371.
- (12) U.S. Department of Commerce, Environmental Data Service. 1972. Local Climatological Data, Annual Summary with Comparative Data, Johnston Island, Pacific, National Climatic Center, Asheville, N.C.
- (13) Environmental Protection Agency. 1976. Quality Criteria for Water, Washington, D. C. 20460
- (14) Environmental Protection Agency. 1975. Water Programs, National Interim Primary Drinking Water Regulations, Federal Register, Part IV, December 24, Vol. 40, No. 248.

- (15) Safe Drinking Water Act. 1973. Public Law 93-523; 88 Stat. 1660 93rd Congress, 2nd Session.
- (16) Department of the Air Force. 1974. Final Environmental Statement on the Disposition of Orange Herbicide by Incineration.
- (17) McKee, J. E. and H. W. Wolf. 1963. Water Quality Criteria, 2nd Edition, The Resources Agency of California, State Water Quality Control Board, Publication No. 3-A.
- (18) The Chemical Rubber Co. 1968-69. Handbook of Chemistry and Physics, 49th Edition, Cleveland, Ohio 44128.
- (19) Hoak, R. D. 1957. The Causes of Tastes and Odors in Drinking Water, Proc. 11th Ind. Waste Conf. Purdue Univ. Engr. 41:229.
- (20) Buttschell, R. H., A. A. Rosen, F. M. Middleton and Ettinger, M. B. 1959. Chlorine Derivatives of Phenol Causing Taste and Odor, J.A.W.W.A., 51:205.
- (21) Aly, O. M. and S. D. Faust. 1964. Studies on the Fate of 2,4-D and Ester Derivatives in Natural Surface Waters, J. Agric. Food Chem., 12:541.
- (22) Meissner, G. 1977. Personal communication to B. Vigon, Battelle Columbus Laboratories.
- (23) Chan, A.S.Y. and Ken Terry (1975) Analysis of Pesticides by Chemical Derivatization, I. A New Procedure for the Formation of 2-Chlorethyl Esters of Ten Herbicidal Acids, J. Assoc. Off. Anal. Chem., 58(6):1294.
- (24) Dupuy, A. E., T. J. Forehand, and H. Tai (1975), Determination of 2,4-Dichlorophenoxyacetic Acid in Wheat Grain, J. Agric. Food Chem., 23(4):827.
- (25) Meagher, W. R. (1966) Determination of 2,4-Dichlorophenoxyacetic Acid and 2-(2,4,5-Trichlorophenoxy)propionic Acid in Citrus by Electron Capture Gas Chromatography, J. Agric. Food Chem., 14:374.
- (26) McCone, C. E. and R. J. Hance (1972) Determination of Residues of 2,4,5-Trichlorophenoxyacetic Acid in Soil by Gas Chromatography of the n-Butyl Esters, 69:204.
- (27) Woodham, D. W., et al., (1971) An Improved Gas Chromatographic Method for the Analysis of 2,4-D Free Acid in Soil, 19(1):186.
- (28) Yip, G. and S. G. Howard (1971), Improved Method for the Determination of Chlorophenoxy Acid Residues in Total Diet Samples, J. Assoc. Off. Anal. Chem., 54:966.
- (29) Yip, G. (1971), Diazomethane Methylation of a Mixture of Chlorophenoxy Acids and Dinitrophenols, J. Assoc. Off. Anal. Chem., 54:970.

- (30) Yip, G. (1962), Herbicide and Plant Growth Regulators, *J. Assoc. Off. Anal. Chem.*, 45:367.
- (31) Yip, G. (1964), Determination of Herbicides in Oils, *J. Assoc. Off. Anal. Chem.*, 47:1116.
- (32) Schultz, D. P. 1973. Dynamics of a Salt of 2,4-Dichlorophenoxyacetic Acid in Fish, Water, and Hydrosol, *J. Agr. Food Chemistry*, 21:186.
- (33) Saunders, H. O. 1971. Toxicities of Some Herbicides to Six Species of Freshwater Crustaceans, *J. Water Poll. Control Fed.*, 42:1544.
- (34) Hughes and Davis. 1963. In Department of the Air Force. 1974. Final Environmental Statement on the Disposition of Orange Herbicide by Incineration.
- (35) Butler. 1965. In Department of the Air Force. 1974. Final Environmental Statement on the Disposition of Orange Herbicide by Incineration.
- (36) Lawrence. 1966. In Department of the Air Force. 1974. Final Environmental Statement on the Disposition of Orange Herbicide by Incineration.
- (37) National Academy of Sciences. 1977. Drinking Water and Health, Recommendations, Promulgated by the Environmental Protection Agency, *Federal Register*, Vol. 42, No. 132, July 11.
- (38) Heinz. (M/V Vulcanus Chief Engr.) 1977. Personal Communication to D. Brown, Battelle Columbus Laboratories.
- (39) Brooks, N. H. 1959. Diffusion of Sewage in An Ocean Current, In Proc. of the Int's. Conf. on Waste Disposal in the Marine Environment, Pergamon Press, New York.
- (40) Johnson, M. C., et al., 1974. Methodology for Chemical Hazard Prediction, Technical Paper No. 10, Dept. of Defense Explosives Board, Washington, D.C.
- (41) Fair, G. M., J. C. Geyer, and D. A. Okun. 1968. Water and Wastewater Engineering, Vol. 2, Water Purification and Wastewater Treatment and Disposal, John Wiley and Sons, Inc., New York.
- (42) Hann, R. W., Jr. and Jensen, P. A. 1974. Water Quality Characteristics of Hazardous Materials. Environmental Engineering Division, Civil Engineering Department, Texas A&M University.
- (43) National Academy of Sciences. 1977. Drinking Water and Health. Safe Drinking Water Committee, Advisory Center on Toxicology, Assembly of Life Sciences, National Research Council, Washington, D. C. pgs. 489-509.



PLATE 2. VIEW OF EMPTY DRUMYARD
SHOWING OBSERVATION WELL



PLATE 1. AERIAL VIEW OF JOHNSTON ISLAND,
SHOWING INCOMPLETE REEF

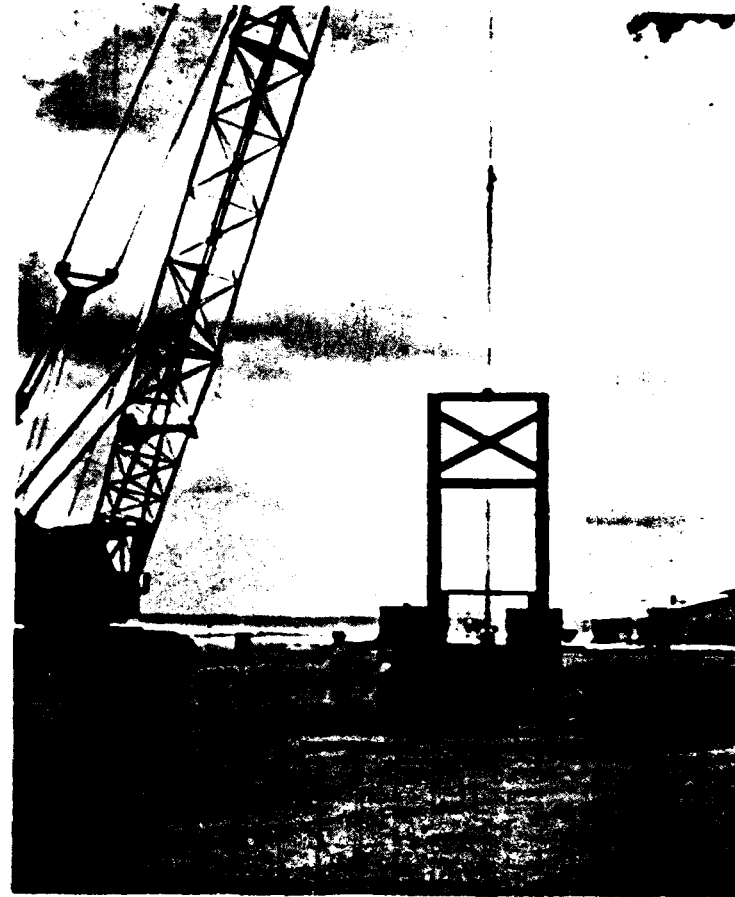
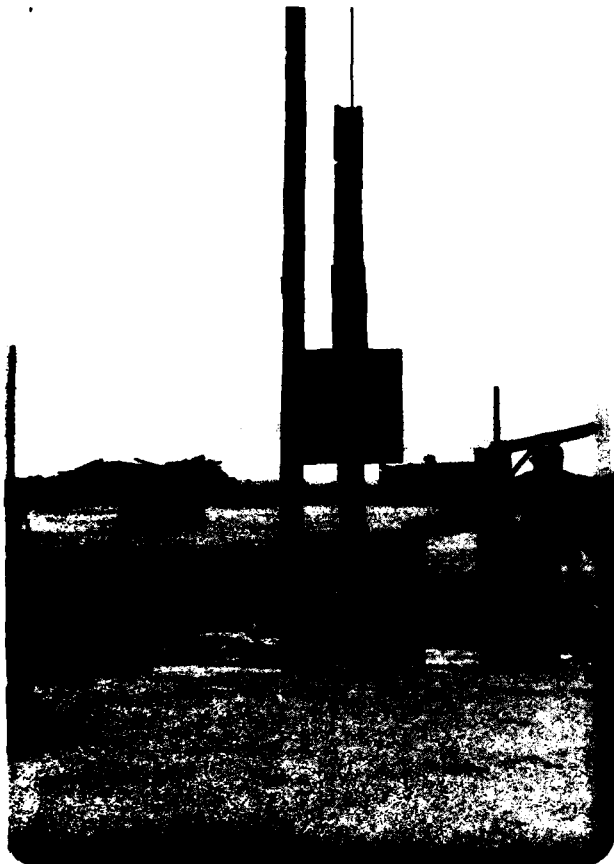

PLATE 3. TWO VIEWS OF DRUM CRUSHER. LEFT HAND VIEW SHOWS STANDING WATER IMMEDIATELY AFTER SHOWER, AND STAIN FROM RESIDUAL DIESEL FUEL EXPELLED FROM DRUMS



PLATE 4. R-5 REFUELER. NOTICE NO IDENTIFICATION ON TANK



PLATE 5. DIKED AREA. SPILLS OF SEVERAL HUNDRED GALLONS COULD BE CONTAINED WITHIN THE PLASTIC LINED AREA

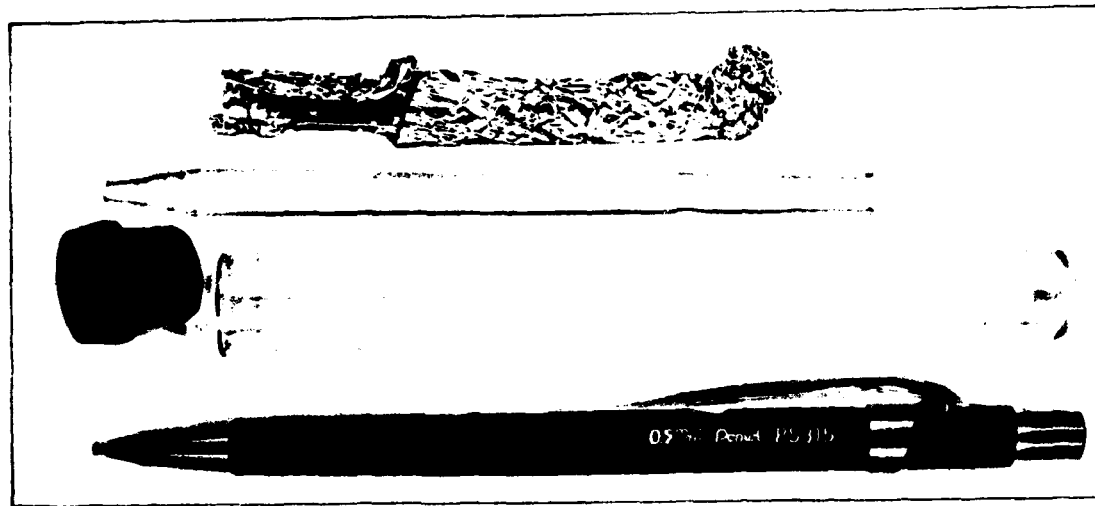

PLATE 6. CHROMOSORB TUBE, ALUMINUM FOIL WRAP, AND STORAGE TUBE.
PENCIL ADDED FOR SCALE. CHROMOSORB MATERIAL IN LEFT
1/3 OF TUBE

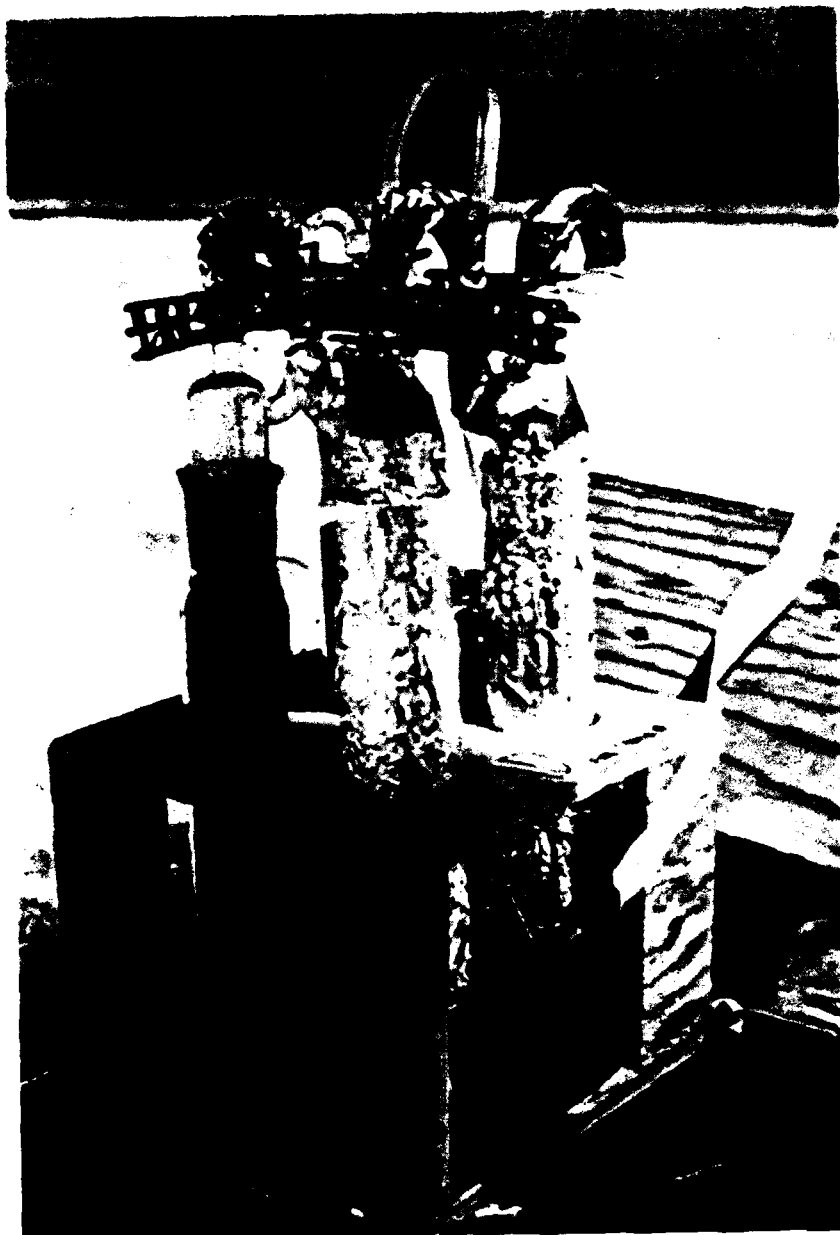

PLATE 7. BENZENE IMPINGER SETUP. BENZENE FLASKS ARE WRAPPED IN ALUMINUM FOIL TO PREVENT PHOTO-DECOMPOSITION OF TRAPPED SPECIES



PLATE 8. WATER SAMPLING LOCATION OFF SHIP BOW. ANOTHER SITE WAS LOCATED APPROXIMATELY 10 METERS OFF THE BOW

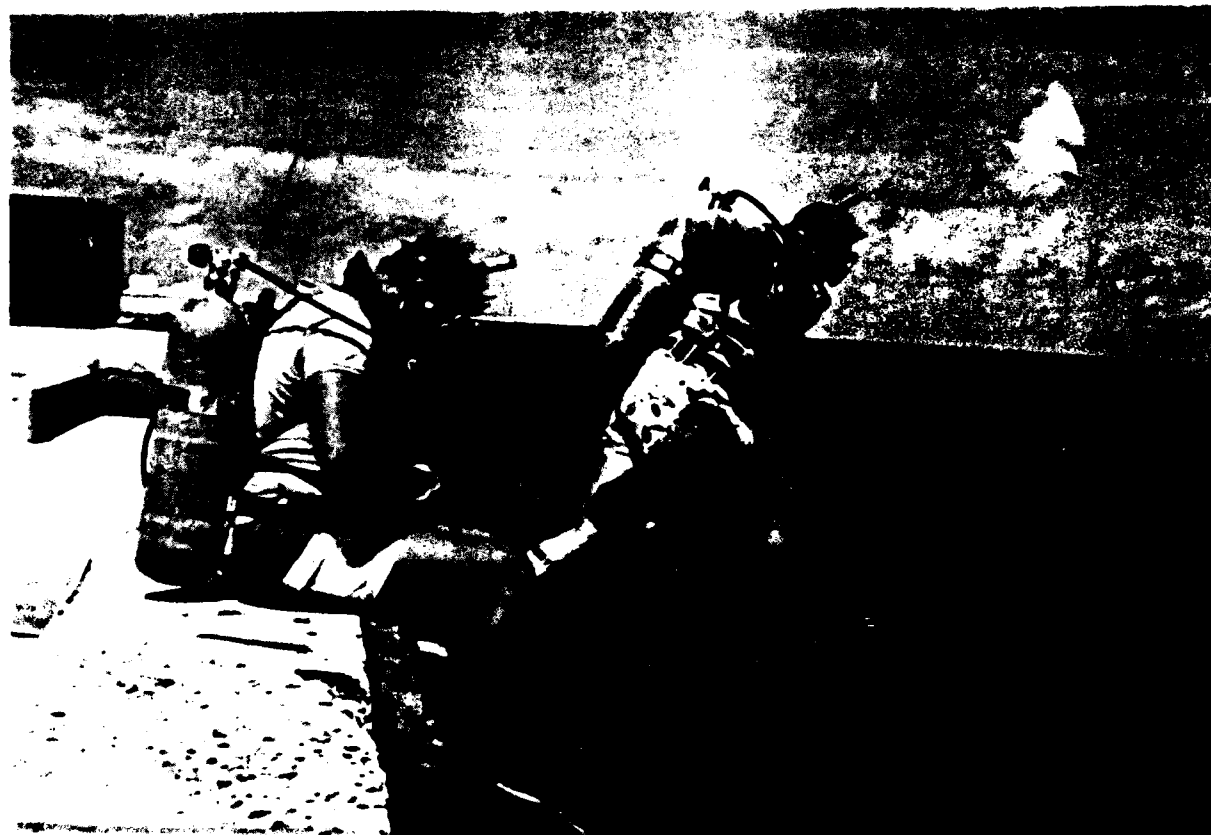
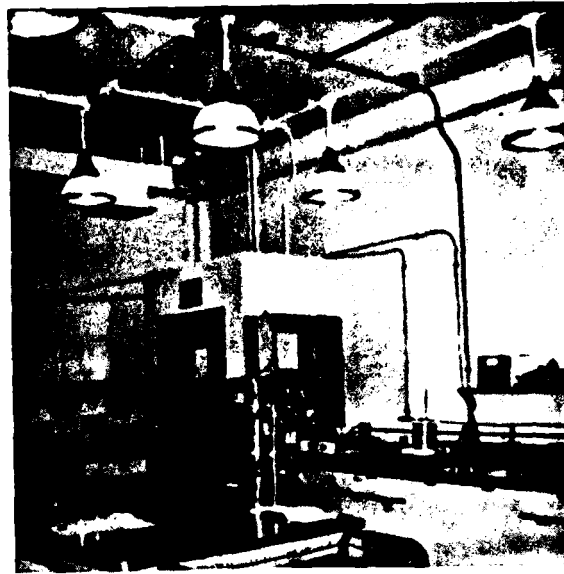

PLATE 9. SEDIMENT SAMPLING. SCUBA GEAR REQUIRED BECAUSE OF DEPTH. OBSERVATION OF DIVERS LED TO UNDERSTANDING OF SURFACE CURRENTS



PLATES 10, 11, 12. WATER AND CHROMOSORB
PREPARATION LABORATORY



PLATE 13. SAFETY EQUIPMENT. TAKEN IN DEDRUM FACILITY, SHOWING RESPIRATOR, FACE SHIELD, GLOVES AND APRON

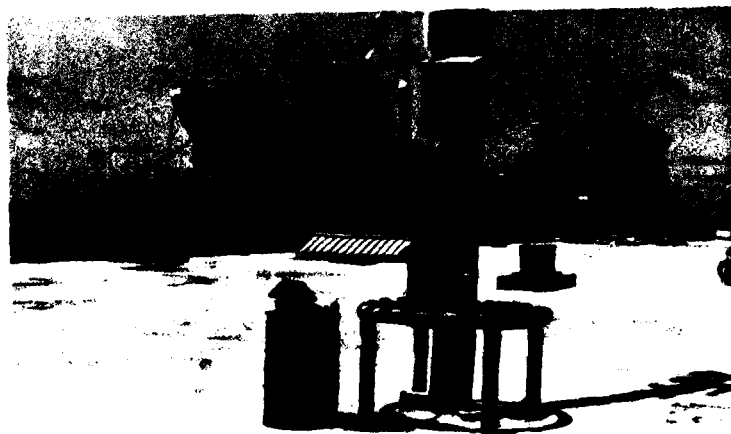

PLATE 14. WHARF AIR SAMPLE SITE. WIND DIRECTION, QUARTERING BOW, EVIDENT FROM FLAGS

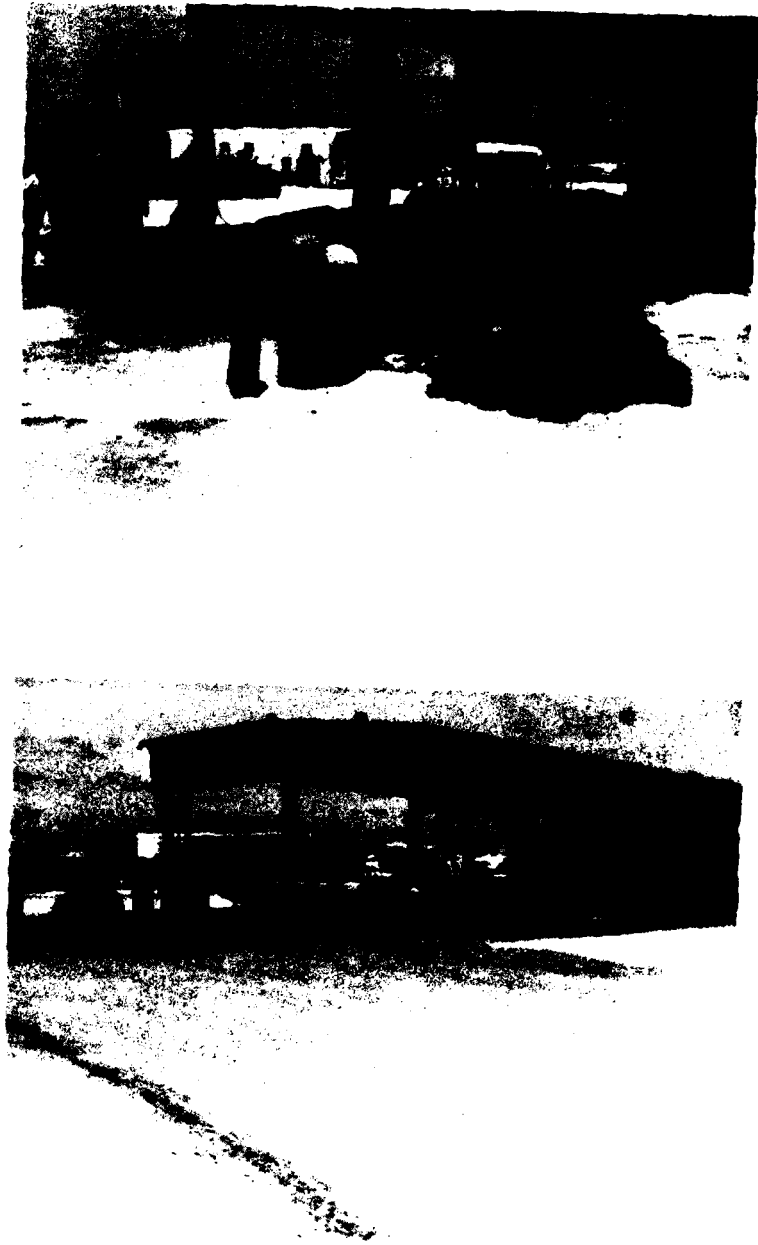

PLATE 15. AIR MONITORING SITE AT DEDRUM. TWO VIEWS SHOWING
EQUIPMENT ON BARREL. LOWER VIEW SHOWS SECOND
SITE AT FAR CORNER, ON BARREL



PLATE 16. NORMAL TOMATO PLANT

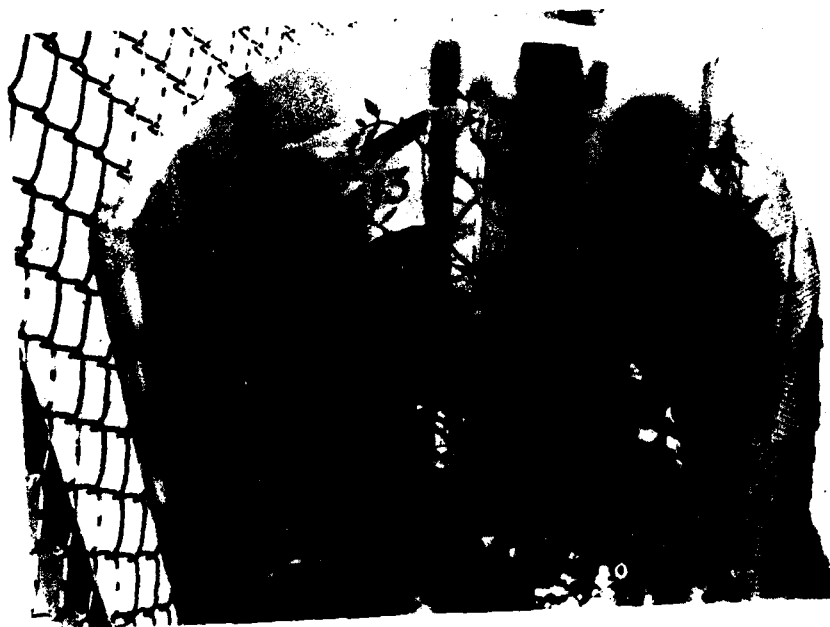

PLATE 17. TOMATO PLANTS WITH LEVEL 2
INJURY (TIP CURLING)



PLATE 18. TOMATO PLANT WITH LEVEL 3
INJURY (STEM CURLING)



PLATE 19. TOMATO PLANT WITH LEVEL 4
INJURY (SEVERE CURLING)



PLATE 20. NATIVE FLORA DOWNWIND OF DRUMMYARD.
TOMATO PLANT LOCATION IN BACKGROUND



PLATE 21. EPINASTIC GROWTH IN NATIVE FLORA (OBSERVED
PRIOR TO PACER HO PROJECT)



PLATE 22. INCINERATOR FOR WOOD DUNNAGE

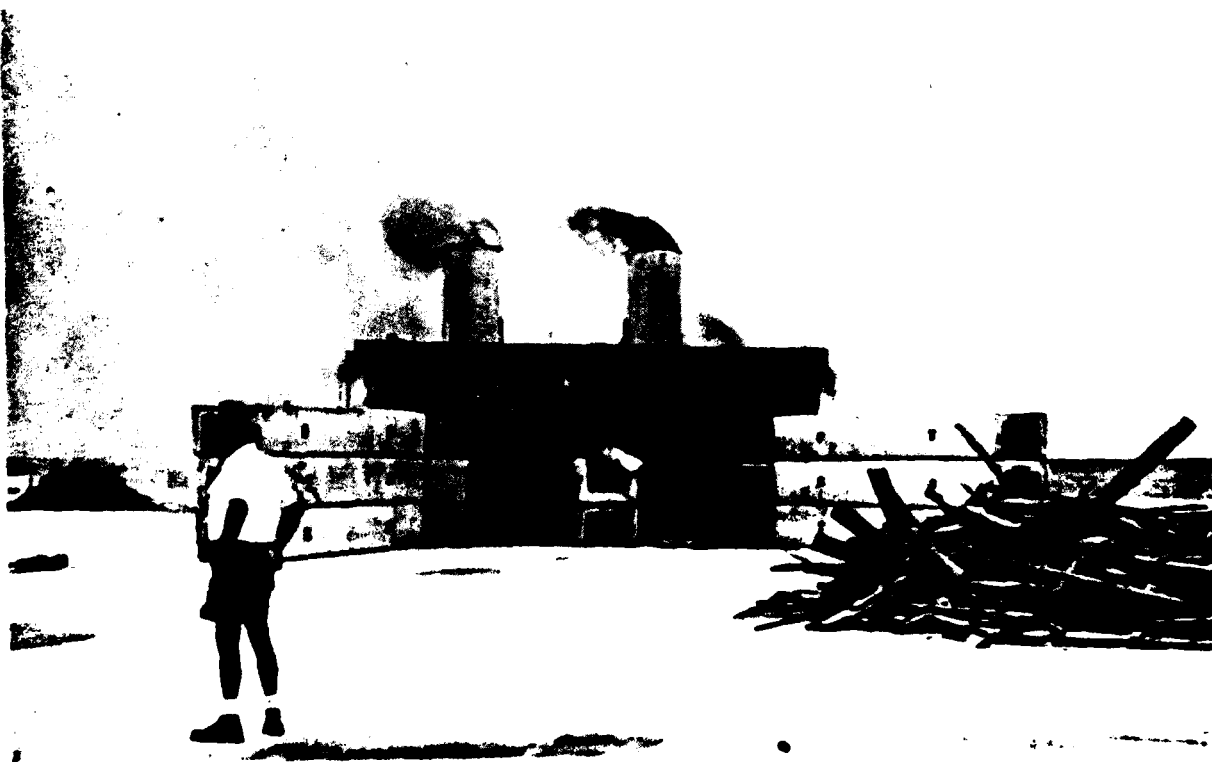

PLATE 23. TYPICAL OPERATION OF INCINERATOR

USAF CEEDO TR-78-38

FINAL REPORT

on

LAND BASED ENVIRONMENTAL MONITORING
AT JOHNSTON ATOLL - DISPOSAL
OF HERBICIDE ORANGE

to

U.S. AIR FORCE OCCUPATIONAL AND
ENVIRONMENTAL HEALTH LABORATORY

September, 1978

PART III

by

Thomas, T.J., Brown, D.P., Harrington, J.,
Stanford, T., Taft, L., and Vigon, B.W.
U.S. Air Force Project Officer: James W. Tremblay, Maj., USAF

BATTELLE
Columbus Laboratories
505 King Avenue
Columbus, Ohio 43201

TABLE OF CONTENTS

	<u>Page</u>
1. INTRODUCTION	1
2. AIR	1
3. METEOROLOGY	13
4. WATER	20
5. BIOTA	20
6. ANALYSIS	20

LIST OF TABLES

1. Air Samples During The Preoperational Period	2
2. Air Samples During First Load.	3-6
3. Air Samples During Interim	7
4. Air Samples During Second Load	8
5. Air Samples During Postoperations.	11,12
6. Water Samples Offshore (WD).	21
7. Water Samples Wastewater Outfall (WO).	22,23
8. Water Samples Saltwater Intake (WS).	24-26
9. Wharf (WF)	31-37
10. Sediments (S).	38
11. Potable Water (PL or P2)	39-41
12. Sewage (SE).	42-44
13. Orange Herbicide Concentrations in Water At Various Locations Around Johnston Island (1973-1977)(a)	45
14. Tide At Johnston Island, July, 1977.	46
Tide At Johnston Island, August, 1977.	47
15. Vascular Plants Known From Johnston Atoll.	48-56
16. Insects Recorded from Johnston Atoll: Adapted from Chilson (1953)	57-59
17. Birds From Johnston Atoll	60,61
18. Status of Birds on Johnston Atoll.	62,63
19. Distribution and Status Of Mammals At Johnston Atoll.	64
20. Distribution Of Benthic Marine Algae At Johnston Atoll.	65-67
21. Cnidaria (Coelenterata) From Johnston Atoll	68
22. Distribution And Abundance OF Mollusca From Johnston Atoll	69-71

LIST OF TABLES (con't)

23.	Annelida From Johnston Atoll	72
24.	Marine Arthropoda From Johnston Atoll	73-75
25.	Inshore Fishes Recorded From Johnston Atoll.	76-85
26.	Recovery Studies for Water Samples	91
27.	Recovery Studies on Wipe Sample Analytical Procedure	92
28.	Equipment Listing, Project Pacer HO Johnston Island Effort . .	93-103
29.	Bulk Chemicals Listing, Project Pacer HO Johnston Island Effort.	104-105
30.	Analytical Data For Chromosorb (Air) Samples	105-113
31.	Analytical Data For Water Samples.	113-118
32.	Analytical Data For Drum Rinse Samples	118-126
33.	Analytical Data For Ship Wipe Samples.	127-130
34.	Analytical Data for Ship's Impinger, Probe, and Line Rinse Samples	130-132
35.	Analytical Data For Ship's Chromosorb (Air) Samples.	132-134
36.	Analytical Data For Ship's Tank Rinse Samples.	135
37.	Analytical Data For Ship's Water Samples	136
38.	Analytical Data For Dunnage Burn Samples	137

LIST OF FIGURES

1.	Weather Observations at NOAA Station, 1977	14-19
2.	Breeding Cycles of Seabirds at Johnston Atoll.	86
3.	Monthly Cumulative Bird Populations, Johnston Atoll	87
4.	Monthly Mean Shorebird Populations for Johnston Atoll.	88
5.	Areas Used by Sooty Terns and Wedge-Tailed Shearwaters on Sand Island, Johnston Atoll, 1965	89
6.	Nesting Areas of Ground Nesting Birds (Except Sooty Terns) On The Original Portion of Sand Island, Johnston Atoll, 1963	90
7.	Nesting Areas of Birds Which Normally Nest in Low Vegetation on the Original Portion Of Sand Island, Johnston Atoll, 1963. .	90

DETAILED ENVIRONMENTAL ANALYSIS OF
PROJECT PACER HO

1. INTRODUCTION

This report is part III of a 3-part report on the environmental consequences of a project conducted on Johnston Island, labeled Project Pacer HO, designed to remove and incinerate the stocks of Herbicide Orange stored on Johnston Island since 1972. The three parts to the report are as follows:

- Part I Executive Summary
- Part II Detailed Environmental Analysis
- Part III Supporting Raw Data

The Part III report is concerned only with the reporting of raw data and substantiating evidence collected at the site. No interpretation of results is provided within this report. The report is organized as follows:

1. Introduction
2. Air Monitoring Data
3. Water Monitoring Data
4. Biota Data
5. Analysis

Detailed data in each area are provided below.

2. AIR

Air samples were collected and analyzed by Battelle for the period July 24, 1977 through August 26, 1977. Both Chromosorb tubes and benzene impinger samples were collected, with the intention being for the analysis of 2,4-D and 2,4,5-T concentrations by Battelle Laboratory of the Chromosorb samples and the analysis of the benzene samples by another laboratory for 2,3,7,8-tetra-chlorodibenzo-p-dioxin (TCDD). Tables 1 through 5 present all of the air samples

TABLE 1. AIR SAMPLES DURING THE PREOPERATIONAL PERIOD

Sample Number (Code)	Time on (Min)	Flow (Lit/Min)	Volume Sampled (Liters)	Concentration of 2,4-D ($\mu\text{g}/\text{m}^3$)	Concentration of 2,4,5-T ($\mu\text{g}/\text{m}^3$)
AM24Y709W	265	1.0	265		
CM24Y709J	355	0.50	117.5	ND	ND
AW24Y709W	265	1.0	265		
CW24Y709J	355	0.50	117.5	ND	ND
AD24Y709W	230	1.0	230		
CD24Y709J	330	0.50	165	Trace	Trace
AB24Y709W	270	1.0	270		
AM25Y709W	275	1.0	275		
CM25Y709J	285	0.50	142.5	ND	ND
AW25Y709W	265	1.0	265		
CW25Y709J	310	0.50	155	ND	Trace
CC25Y709J	310	0.50	155	ND	ND
AB25Y709W	260	1.0	260		
AD25Y709W	265	1.0	265		
CD25Y709J	260	0.50	130	Trace	Trace
AM26Y709W	250	1.0	250		
CM26Y709J	325	0.50	162.5	ND	Trace
AW26Y709W	320	1.0	320		
CW26Y709J	320	0.50	160	ND	ND
AD26Y709W	240	1.0	240		
CD26Y709J	240	0.50	120	0.23	1.48
AB26Y709W	235	1.0	235		
CN26Y709J	185	0.50	92.5	Trace	Trace
CS26Y709J	185	0.50	92.5	0.57	1.60
CP26Y709J	185	0.50	92.5	0.75	1.87
CP27Y707J	500	0.50	250		
CS27Y707J	488	0.50	244		
CN27Y707J	479	0.50	239.5		
CD27Y708J	482	0.50	241		
CW27Y708J	483	0.50	241.5		
AW27Y708W	166	1.0	166		
CM27Y708J	465	0.50	232.5		
AM27Y708W	250	1.0	250		
AM27Y719W	300	1.0	300		

TABLE 2. AIR SAMPLES DURING FIRST LOAD

Sample Number (Code)	Time on (Min)	Flow (Lit/Min)	Volume Sampled (Liters)	Concentration of 2,4-D ($\mu\text{g}/\text{m}^3$)	Concentration of 2,4,5-T ($\mu\text{g}/\text{m}^3$)
CM27Y719J	480	0.50	240	--	Trace
AW27Y719W	295	1.0	295		
CW27Y719J	470	0.50	235	--	Trace
AD27Y719W	325	1.0	325		
CD27Y719J	590	0.50	295	0.82	1.92
AB27Y719W	310	1.0	310		
CS27Y719J	580	0.50	290	6.92	12.80
CN27Y719J	580	0.50	290	2.26	4.79
CP27Y719J	570	0.50	285	Trace	0.50
CM28Y707J	231	0.50	115.5	--	Trace
AM28Y707W	222	1.0	222		
CW28Y708J	234	0.50	117	--	Trace
AW28Y708W	182	1.0	182		
CD28Y709J	288	0.50	144	2.78	5.42
AD28Y709W	274	1.0	274		
CS28Y709J	255	0.50	127.5	8.60	16.00
AB28Y709W	248	1.0	248		
CN28Y710J	252	0.50	126	8.28	18.33
CP28Y710J	247	0.50	123.5	--	--
AM28Y719W	295	1.0	295		
CM28Y719J	435	0.50	217.5	--	Trace
AW28Y719W	285	1.0	285		
CW28Y719J	425	0.50	212.5	--	Trace
AD28Y719W	300	1.0	300		
CD28Y719J	525	0.50	262.5	1.17	2.36
AB28Y719W	305	1.0	305		
CN28Y719J	510	0.50	255	3.19	6.84
CS28Y719J	510	0.50	255	8.84	15.72
CP28Y719J	510	0.50	255	--	2.58
PP29Y707J	268	0.50	134	4.18	9.23
PV29Y707J	265	0.50	132.5	8.44	16.84
PX29Y707J	263	0.50	131.5	8.62	15.74
AB29Y707W	278	1.0	278		

TABLE 2. (Continued)

Sample Number (Code)	Time on (Min)	Flow (Lit/Min)	Volume Sampled (Liters)	Concentration of 2,4-D (µg/m ³)	Concentration of 2,4,5-T (µg/m ³)
CD29Y707J	235	0.50	117.5	1.98	2.89
AD29Y707W	230	1.0	230		
CW29Y708J	298	0.50	149	Trace	Trace
AW29Y708W	282	1.0	282		
CM29Y708J	287	0.50	143.5	--	--
AM29Y708W	283	1.0	283		
AD29Y722W	240	1.0	240		
CD29Y722J	240	0.50	120	0.91	2.18
AD30Y708W	304	1.0	304		
CD30Y708J	301	0.50	150.5	2.39	5.89
AD30Y719W	280	1.0	280		
CD30Y719J	585	0.50	292.5	1.02	2.14
AB30Y719W	275	1.0	275		
PP30Y719J	225	0.50	112.5	2.43	6.11
PT30Y719J	240	0.50	120	0.57	2.14
PU30Y719J	240	0.50	120	11.77	26.03
AW31Y701W	280	1.0	280		
CW31Y701J	280	0.50	140	ND	0.73
AM31Y701W	285	1.0	285		
CM31Y701J	285	0.50	142.5	ND	0.39
AW31Y708W	232	1.0	232		
CW31Y708J	230	0.50	115	ND	0.67
AM31Y708W	269	1.0	269		
CM31Y708J	267	0.5	133.5	ND	0.67
AB31Y707W	291	1.0	291		
PP31Y707J	259	0.50	129.5	5.09	11.81
PT31Y707J	247	0.50	123.5	12.33	23.29
PU31Y707J	250	0.50	125	3.79	7.64
AD31Y707W	252	1.0	252		
CD31Y707J	251	0.50	125.5	1.71	3.24
AD31Y719W	290	1.0	290		
CD31Y719J	290	0.50	145	1.48	3.37
CD02T709J	262	0.50	131	4.14	7.58

TABLE 2. (Continued)

Sample Number (Code)	Time on (Min)	Flow (Lit/Min)	Volume Sampled (Liters)	Concentration of 2,4-D ($\mu\text{g}/\text{m}^3$)	Concentration of 2,4,5-T ($\mu\text{g}/\text{m}^3$)
ADO2T709J	187	1.0	187		
ADO2T719W	285	1.0	285		
CDO2T719J	285	0.50	142.5	1.33	3.79
ABO2T719W	275	1.0	275		
PP02T719J	230	0.50	115	11.48	26.78
PT02T719J	210	0.50	105	9.71	20.57
PU02T719J	210	0.50	105	11.05	22.00
AMO3T701W	290	1.0	290		
CMO3T701J	290	0.50	145	ND	0.62
AWO3T701W	290	1.0	290		
CW03T701J	290	0.50	145	ND	0.69
PP03T707J	245	0.50	122.5	8.41	17.88
PU03T707J	239	0.50	119.5	8.20	16.90
PT03T707J	233	0.50	116.5	6.01	12.53
CDO3T707J	241	0.50	120.5	2.57	6.31
ADO3T707W	199	1.0	199		
ABO3T707W	256	1.0	256		
CW03T708J	294	0.50	147	ND	1.09
AWO3T708W	290	1.0	290		
AMO3T708W	289	1.0	289		
CMO3T708J	286	0.50	143	ND	1.12
				ND	ND
ADO3T719W	265	1.0	265		
CDO3T719J	265	0.50	132.5	2.87	7.02
ABO3T719W	265	1.0	265		
PZ03T719J	200	0.50	100	13.00	24.70
PQ03T719J	200	0.50	100	9.90	19.40
AMO4T701W	270	1.0	270		
CMO4T701J	270	0.50	135	ND	Trace
AWO4T701W	270	1.0	270		
CW04T701J	270	0.50	135	ND	Trace
PX04T707J	211	0.50	105.5	8.34	19.05
PV04T707J	209	0.50	104.5	7.27	15.50
ABO4T707W	253	1.0	253		

TABLE 2. (Continued)

Sample Number (Code)	Time on (Min)	Flow (Lit/Min)	Volume Sampled (Liters)	Concentration of 2,4-D ($\mu\text{g}/\text{m}^3$)	Concentration of 2,4,5-T ($\mu\text{g}/\text{m}^3$)
AD04T707W	241	1.0	241		
CD04T707J	241	1.0	120.5	3.98	9.05
AW04T708W	278	1.0	278		
CW04T708J	276	0.50	138	ND	Trace
AM04T708W	195	1.0	195		
CM04T708J	272	0.50	136	ND	Trace
AD04T719W	255	1.0	255		
CD04T719J	255	0.50	127.5	2.51	5.80
AB04T719W	255	1.0	255		
PZ04T719J	200	0.50	100	13.60	26.00
PR04T719J	200	0.50	100	16.10	30.80
AW05T701W	260	1.0	260		
CW05T701J	260	0.50	130	ND	Trace
AM05T701W	265	1.0	265		
CM05T701J	265	0.50	132.5	ND	Trace
AB05T707W	252	1.0	252		
PU05T707J	227	0.50	113.5	8.37	16.74
PT05T707J	226	0.50	113	7.88	19.20
CD05T707J	230	0.50	115	ND	ND
AD05T707W	230	1.0	230		
CW05T708J	289	0.50	144.5	Trace	Trace
AW05T708W	287	1.0	287		
CM05T708J	286	0.50	143	5.03	8.46
AM05T708W	283	1.0	283		

TABLE 3. AIR SAMPLES DURING INTERIM

Sample Number (Code)	Time on (Min)	Flow (Lit/Min)	Volume Sampled (Liters)	Concentration of 2,4-D ($\mu\text{g}/\text{m}^3$)	Concentration of 2,4,5-T ($\mu\text{g}/\text{m}^3$)
AD06T708W	253	1.0	253		
CD06T708J	253	0.50	126.5	3.00	7.27
AM06T708W	258	1.0	258		
CM06T708J	258	0.50	129	ND	ND
AD08T708W	264	1.0	264		
CD08T708J	264	0.50	132	1.97	4.55
AM08T708J	271	1.0	271		
CM08T708J	271	0.50	135.5	ND	ND
AM11T708W	259	1.0	259		
CM11T708J	259	0.50	129.5	ND	ND
AW11T708W	253	1.0	253		
CW11T708J	253	0.50	126.5	ND	ND
				ND	ND

TABLE 4. AIR SAMPLES DURING SECOND LOAD

Sample Number (Code)	Time on (Min)	Flow (Lit/Min)	Volume Sampled (Liters)	Concentration of 2,4-D ($\mu\text{g}/\text{m}^3$)	Concentration of 2,4,5-T ($\mu\text{g}/\text{m}^3$)
PT17T713J	184	0.50	92	16.63	27.83
PUI7T713J	188	0.50	94	17.77	30.11
AB17T713W	205	1.0	205		
AD17T713W	195	1.0	195		
CD17T713J	195	0.50	97.5	7.08	13.23
AM17T713W	210	1.0	210		
CM17T713J	210	0.43	90	ND	ND
AD17T719W	225	1.0	225		
CD17T719J	285	0.50	142.5	2.74	7.09
AB17T719W	225	1.0	225		
PT17T719J	195	0.50	97.5	20.82	37.74
PX17T719J	195	0.50	97.5	9.44	16.10
AM17T720W	230	1.0	230		
CM17T720J	230	0.50	115	ND	ND
AM18T707W	240	1.0	240		
CM18T707J	240	0.50	120	ND	ND
CD18T707J	475	0.50	237.5	6.95	16.51
PUI8T707J	180	0.50	90	15.89	25.56
PX18T707J	171	0.50	85.5	22.22	35.91
AB18T707W	200	1.0	200		
AD18T719W	280	1.0	280		
CD18T719J	280	0.50	140	2.43	7.00
AB18T719W	260	1.0	260		
PX18T719J	225	0.50	112.5	6.49	12.62
PV18T719J	220	0.50	110	8.82	16.36
AM18T720W	315	1.0	315		
CM18T720J	315	0.50	157.5	ND	ND
AB20T707W	300	1.0	300		
PX20T707J	229	0.50	114.5	10.92	17.73
PV20T707J	238	0.50	119.0	10.08	16.39
AD20T707W	300	1.0	300		
CD20T707J	302	0.50	151	4.77	10.99
AM20T708W	317	1.0	317		
CM20T708J	323	0.50	161.5	ND	Trace

TABLE 4. (Continued)

Sample Number (Code)	Time on (Min)	Flow (Lit/Min)	Volume Sampled (Liters)	Concentration of 2,4-D ($\mu\text{g}/\text{m}^3$)	Concentration of 2,4,5-T ($\mu\text{g}/\text{m}^3$)
AW20T708W	336	1.0	336		
CW20T708J	336	0.50	168	ND	Trace
AD20T719W	285	1.0	285		
CD20T719J	285	0.50	142.5	1.89	5.33
AB20T719W	290	1.0	290		
PU20T719J	190	0.50	95	22.53	38.00
PR20T719J	205	0.50	102.5	11.41	20.78
AM20T720W	315	1.0	315		
CM20T720J	315	0.50	157.5	1.14	2.54
AW20T720W	270	1.0	270		
CW20T720J	330	0.50	165	Trace ND	Trace ND
AB21T707W	301	1.0	301		
AM21T707W	300	1.0	300		
AW21T707W	300	1.0	300		
AD21T707W	300	1.0	300		
CM21T707J	329	0.50	164.5	ND	ND
PU21T707J	218	0.50	109	9.08	15.96
PX21T707J	159	0.50	79.5	12.70	22.77
CD21T707J	300	0.50	150	5.87	15.27
CW21T707J	300	0.50	150	ND	Trace
AD21T719W	280	1.0	280		
CD21T719J	280	0.50	140	2.21	5.79
AB21T719W	280	1.0	280		
PT21T719J	210	0.50	105	4.57	8.38
PY21T719J	210	0.50	105	6.76	13.24
AW21T720W	295	1.0	295		
CW21T720J	295	0.50	147.5	ND	ND
AM21T720W	295	1.0	295		
CM21T720J	295	0.50	147.5	ND	ND
AB22T707W	300	1.0	300		
AD22T707W	300	1.0	300		

TABLE 4. (Continued)

Sample Number (Code)	Time on (Min)	Flow (Lit/Min)	Volume Sampled (Liters)	Concentration of 2,4-D ($\mu\text{g}/\text{m}^3$)	Concentration of 2,4,5-T ($\mu\text{g}/\text{m}^3$)
AW22T707W	300	1.0	300		
AM22T707W	303	1.0	303		
CD22T707J	300	0.50	150	4.67	12.53
CM22T707J	303	0.50	151.5	ND	Trace
CW22T707J	300	0.50	150	ND	Trace
PU22T707J	237	0.50	118.5	11.56	18.90
PX22T707J	216	0.50	108	21.20	40.28
AD22T719W	280	1.0	280		
CD22T719J	280	0.50	140	3.93	10.14
AB22T719W	280	1.0	280		
PX22T719J	190	0.50	95	6.63	14.63
PR22T719J	250	0.50	125	15.36	24.96
AW22T720W	285	1.0	285		
CW22T720J	285	0.50	142.5	Trace	Trace
AM22T720W	280	1.0	280		
CM22T720J	280	0.50	140	Trace	Trace
AB23T707W	98	1.0	98		
AD23T707W	307	1.0	307		
AW23T707W	300	1.0	300		
AM23T707W	300	1.0	300		
CS23T707J	98	0.50	49	7.35	18.78
CN23T707J	97	0.50	48.5	2.27	6.60
CD23T707J	307	0.50	153.5	6.91	14.27
CW23T708J	300	0.50	150	ND	Trace
CM23T708J	246	0.50	123	ND	Trace

TABLE 5. AIR SAMPLES DURING POSTOPERATIONS

Sample Number (Code)	Time on (Min)	Flow (Lit/Min)	Volume Sampled (Liters)	Concentration of 2,4-D ($\mu\text{g}/\text{m}^3$)	Concentration of 2,4,5-T ($\mu\text{g}/\text{m}^3$)
AB23T717W	305	1.0	305		
CS23T717J	305	0.50	152.5	2.96	8.26
CN23T717J	305	0.50	152.5	3.41	8.13
AD23T717W	300	1.0	300		
CD23T717J	300	0.50	150	4.93	9.53
AW23T717W	285	1.0	285		
CW23T717J	285	0.50	142.5	ND	Trace
AM23T717W	290	1.0	290		
CM23T717J	290	0.50	145	Trace	Trace
AB24T707W	300	1.0	300		
AD24T707W	300	1.0	300		
AW24T707W	131	1.0	131		
AM24T707W	300	1.0	300		
CS24T707J	300	0.50	150	1.33	5.00
CN24T707J	300	0.50	150	3.33	8.53
CD24T707J	300	0.50	150	1.60	4.80
CW24T707J	313	0.50	156.5	ND	Trace
CM24T707J	300	0.50	150	ND	Trace
AB24T716W	300	1.0	300		
CS24T716J	300	0.50	150	3.33	10.07
CN24T716J	300	0.50	150	3.27	7.40
AD24T716W	300	1.0	300		
CD24T716J	300	0.50	150	5.40	12.20
AW24T716W	295	1.0	295		
CW24T716J	295	0.50	147.5	Trace	Trace
AM24T716W	295	1.0	295		
CM24T716J	295	0.50	147.5	ND	Trace
AB25T707W	307	1.0	307		
AD25T707W	303	1.0	303		
AW25T707W	300	1.0	300		
AM25T707W	297	1.0	297		
CS25T707J	307	0.50	153.5	2.80	7.88
CN25T707J	305	0.50	152.5	2.75	7.08

TABLE 5. (Continued)

Sample Number (Code)	Time on (Min)	Flow (Lit/Min)	Volume Sampled (Liters)	Concentration of 2,4-D ($\mu\text{g}/\text{m}^3$)	Concentration of 2,4,5-T ($\mu\text{g}/\text{m}^3$)
CD25T707J	303	0.50	151.5	4.22	8.51
CW25T707J	300	0.50	150	ND	ND
CM25T707J	297	0.50	148.5	ND	ND
AB25T716W	300	1.0	300		
CS25T716J	300	0.50	150	* 3.20	14.20
CN25T716J	300	0.50	150	* 3.60	13.13
AD25T716W	300	1.0	300		
CD25T716J	300	0.50	150	6.60	16.93
AW25T716W	300	1.0	300		
CW25T716J	300	0.50	150	* ND	4.47
CM25T716J	300	0.50	150	* ND	2.93
AB26T707W	294	1.0	294		
AD26T707W	292	1.0	292		
AW26T707W	288	1.0	288		
AM26T711W	300	1.0	300		
CS26T707J	294	0.50	147	* 1.43	8.10
CN26T707J	293	0.50	146.5	1.50	4.51
CD26T707J	292	0.50	146	* 3.56	23.63
CW26T709J	300	0.50	150	* ND	3.53
CM26T707J	338	0.50	169	* ND	9.88
AW26T716W	305	1.0	305		
CW26T716J	305	0.50	152.5	* ND	3.34
AM26T716W	300	1.0	300		
CM26T716J	300	0.50	150	* ND	4.13

taken, and the results to date, for the preoperational, first load, interim, second load, and postoperational periods.

The code provided for sample identification is straight forward, as discussed below:

First Two Digits

AM	Benzine Impinger at Meteorology Building
AB	Benzine Impinger at Dedrum Downwind Corner
AW	Benzine Impinger at Clock Site
AD	Benzine Impinger Downwind of Dedrum Site
CM	Chromosorb Tube at Meteorology Building
CW	Chromosorb Tube at Dock Site
CC	Chromosorb Tube in Clothing Change Building
CD	Chromosorb Tube Downwind of Dedrum Activities
CN	Chromosorb Tube at Northwest Corner of Dedrum
CS	Chromosorb Tube at Southwest Corner of Dedrum
CP	Chromosorb Tube at East Wall of Dedrum
PP	Personal Sampler on Pump Operator
PR	Personal Sampler on Spray Operator
PX	Personal Sampler on Spray Operator
PY	Personal Sampler on Spray Operator
PU	Personal Sampler on Drum Puncturers
PV	Personal Sampler on Drum Puncturers
PQ	Personal Sampler on Drum Puncturers
PZ	Personal Sampler on Drum Puncturers

Third & Fourth Digits: Day of Month

Fifth Digit: Y July
T August

Sixth & Seventh Digits: Sample Start Time, 24-Hour Local

Eighth Digit: Person Taking Sample

3. METEOROLOGY

The meteorological conditions observed during the project are summarized in Figure 1.

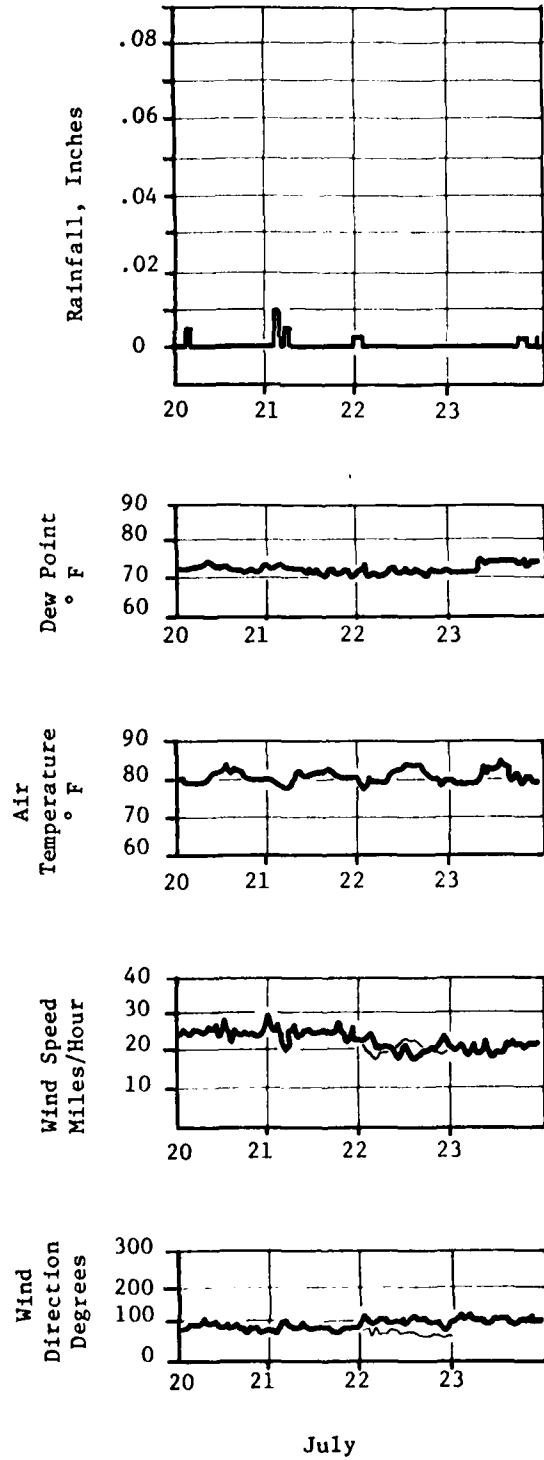

FIGURE 1. WEATHER OBSERVATIONS AT NOAA STATION, 1977

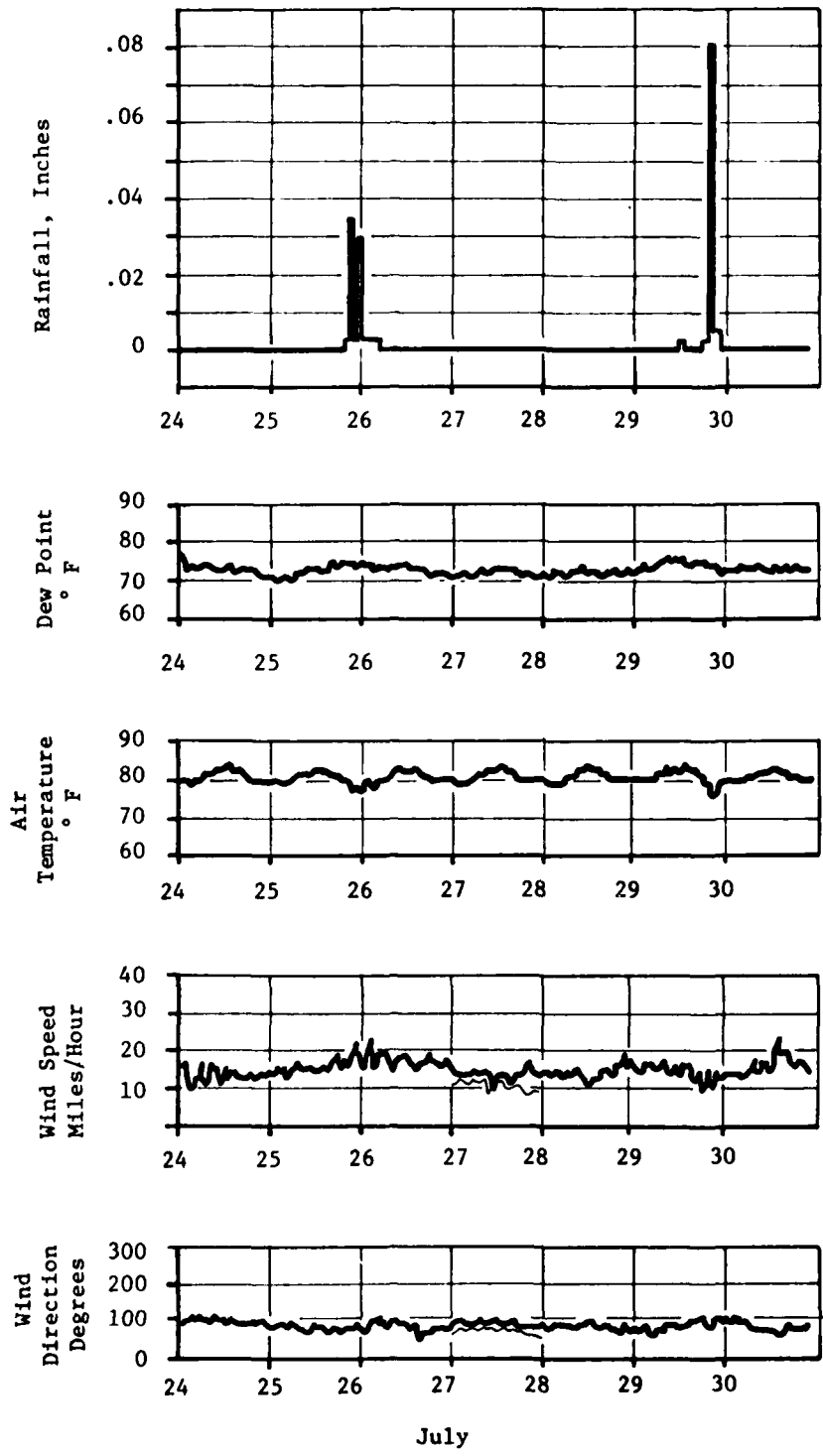

FIGURE 1. (Continued)

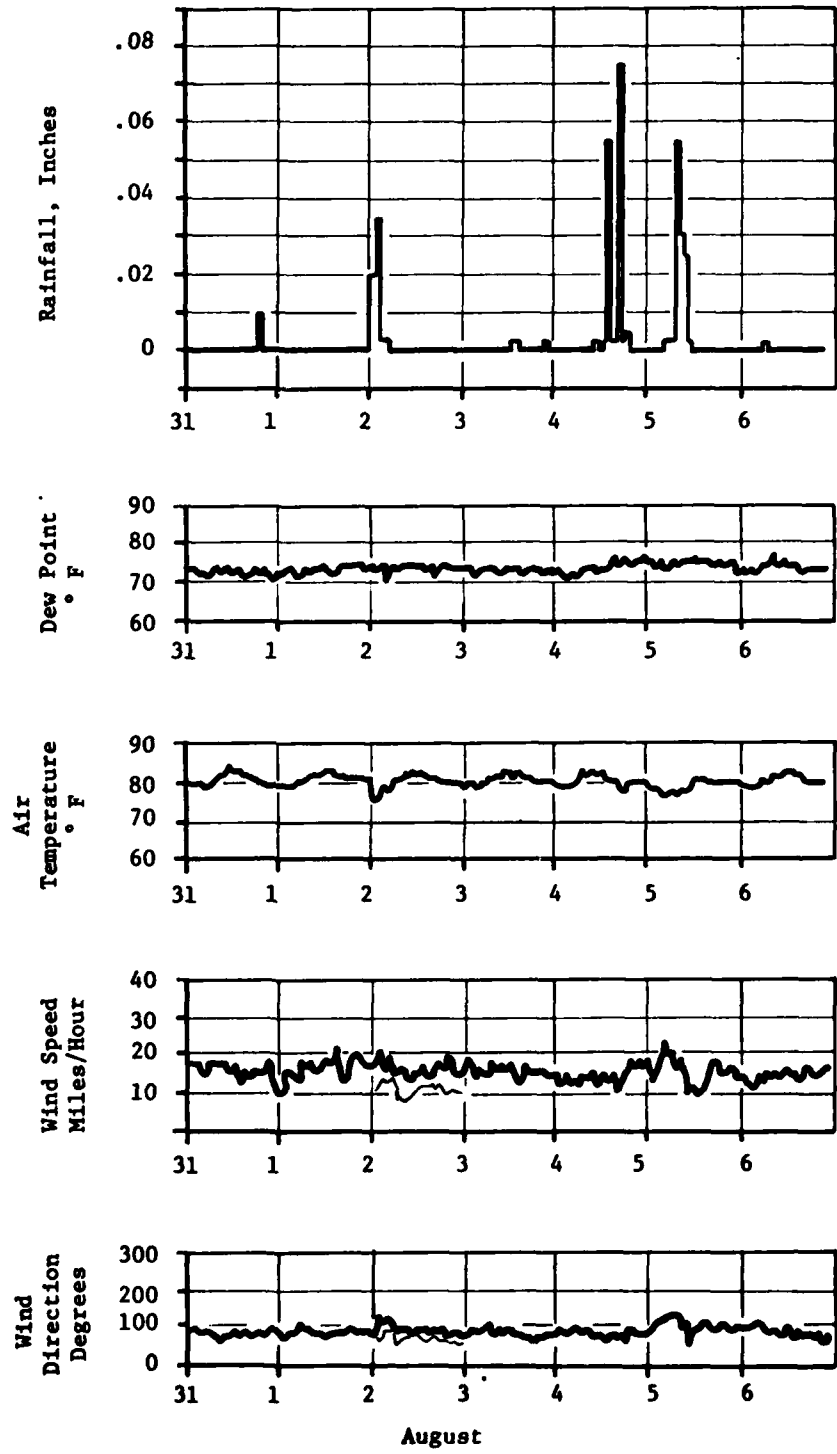

FIGURE 1. (Continued)

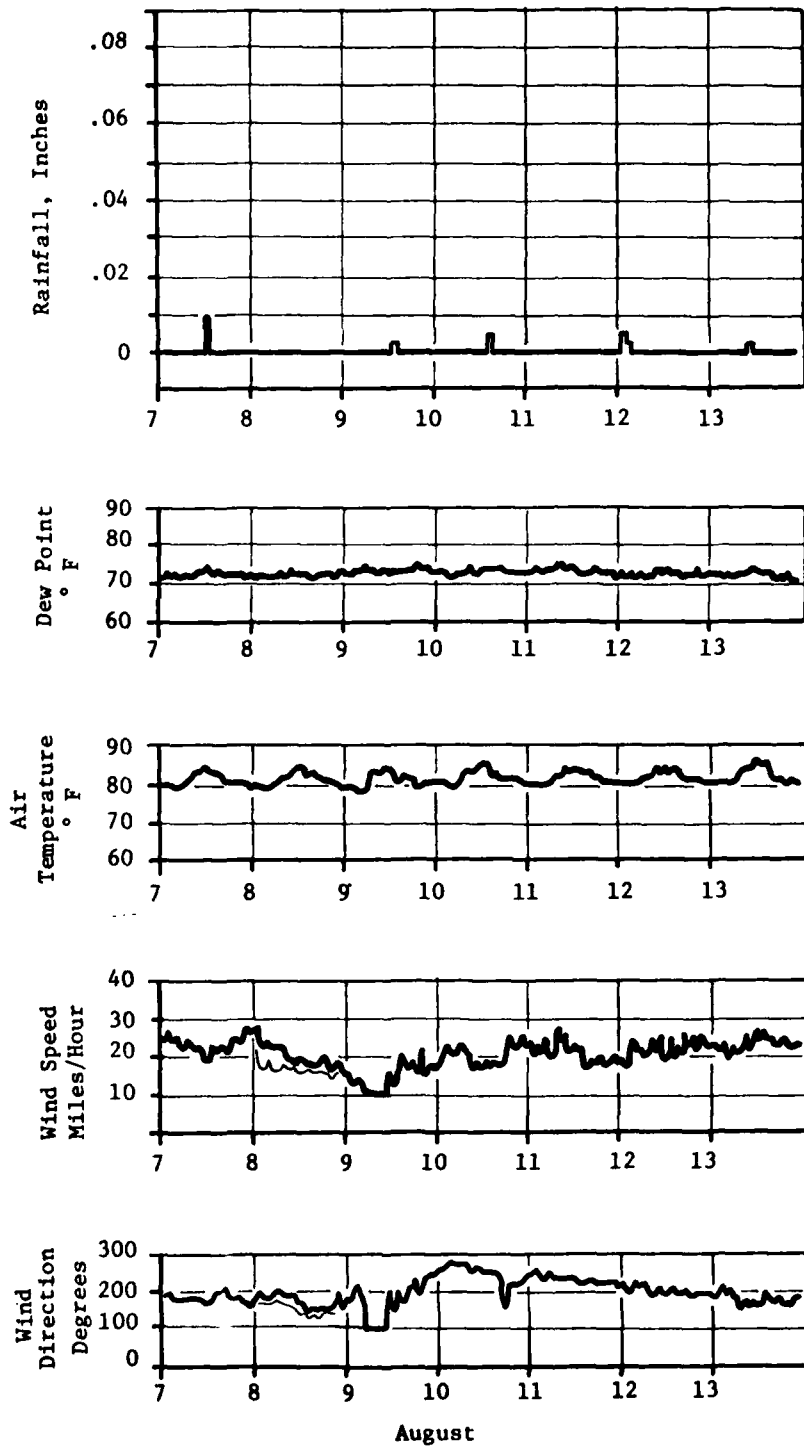

FIGURE 1. (Continued)

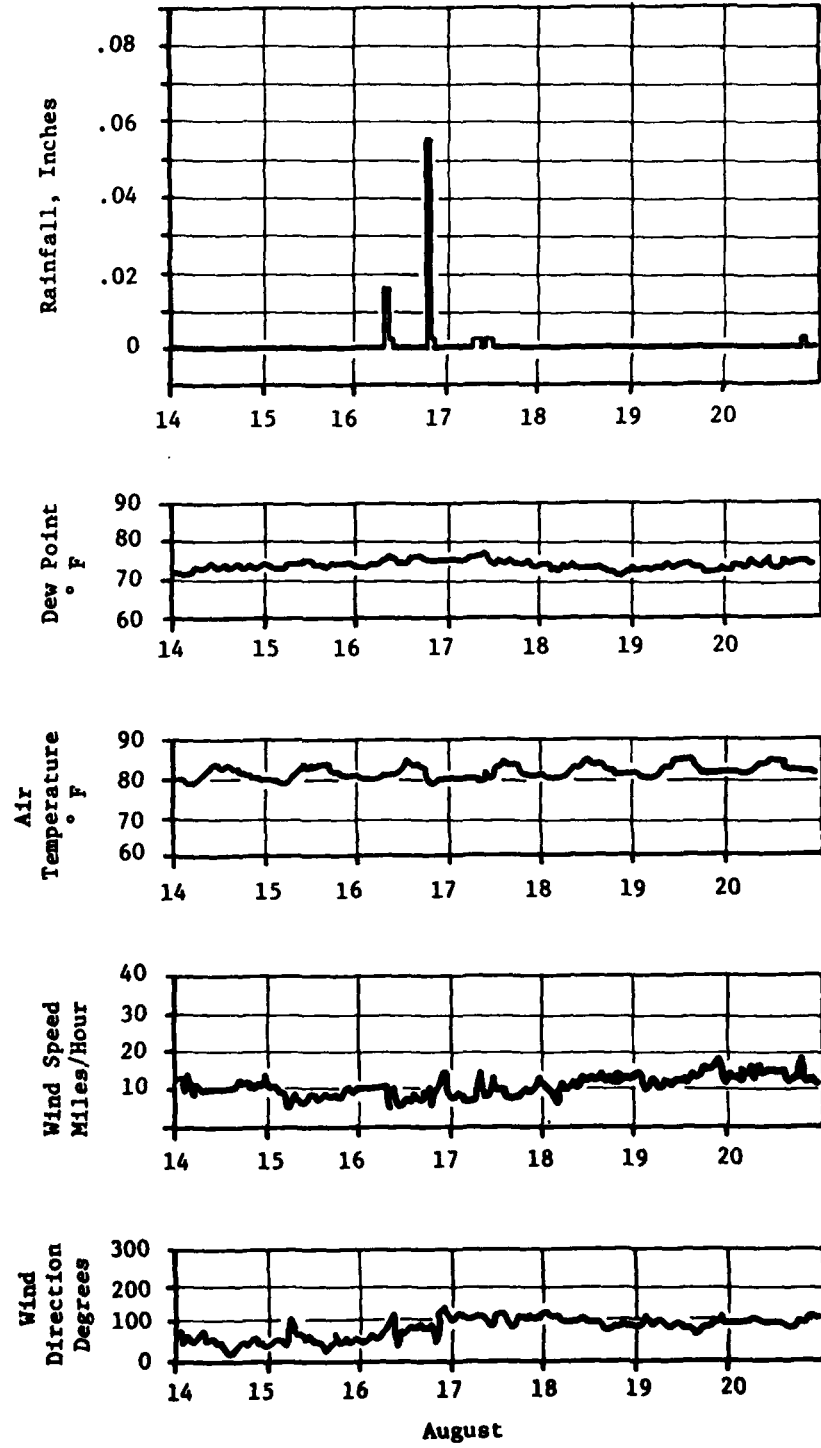

FIGURE 1. (Continued)

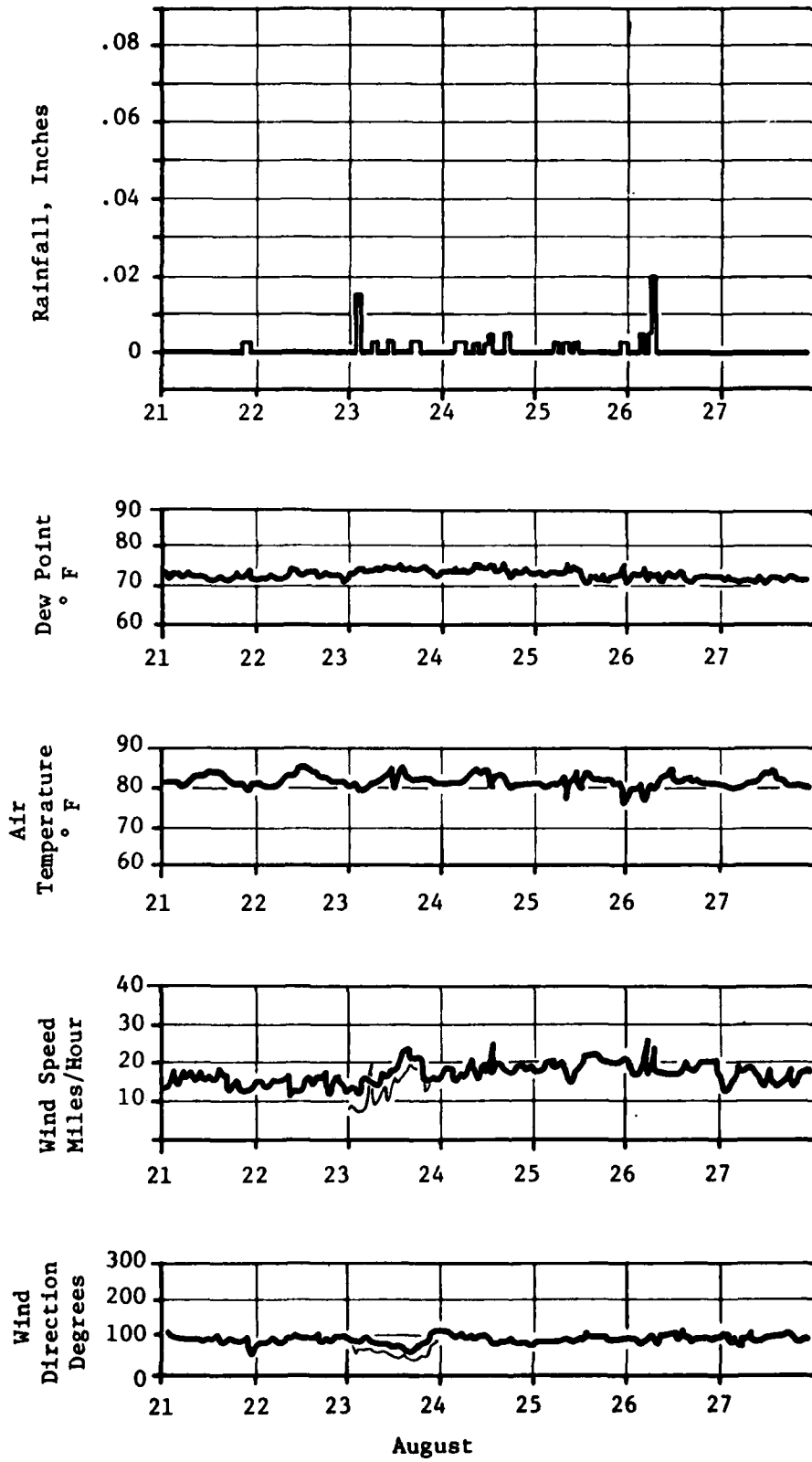

FIGURE 1. (Continued)

4. WATER

Water, sewage, and sediment samples were taken by Battelle before, during, and after operations. Many of the collected samples were analyzed by Battelle on the island for 2,4-D and 2,4,5-T. The remainder were shipped to various laboratories for different analyses and archiving.

Tables 6 through 12 are the detailed results of monitoring of offshore, the waste outfall, the saltwater intake, the wharf, sediments, drinking water, and raw sewage.

Table 13 presents the historical H₀ concentrations of Johnston Island, while Table 14 details the tides during July and August, 1977.

5. BIOTA

An extensive survey has been made by the Smithsonian Institute on the flora and fauna of Johnston Atoll. Their published results are replicated below, in Tables 15 through 25 and Figures 2 through 7.

6. ANALYSIS

The analytical efforts on Johnston Island included recovery studies for water and wipe samples. These are presented in Tables 26 and 27, respectively.

The equipment used on Johnston Island constituted an extensive list. Battelle has identified both the quantities supplied and quantities needed in Table 28. The chemicals used are documented in Table 29.

Actual lab results for each sample are presented following Table 29.

TABLE 6. WATER SAMPLES OFFSHORE (WD)

	Date	Time	Depth & Time	DO, ppm	Temp., °C	Comments	Methyl Esters 2,4-D ppb	Methyl Esters 2,4,5-T ppb	Detection Limit, (units)
Grab Baseline Dedrum Area	7-24	1500	5 meters 1430	7.4	26	Single Sample Trace \leq 0.2 ppb	ND	Trace	0.1 ppb
Grab Operational Dedrum Facility	8-5	1400	2 meters 1345 8 meters	5.9	29	Single Sample	ND	ND	0.1 ppb
Grab Operational Dedrum	8-22	0800	--	--	--	Single Sample	ND	Trace	0.1 ppb
Grab Post Operational	8-24	0800	--	--	--	Single Sample	ND	Trace	0.1 ppb

TABLE 7. WATER SAMPLES WASTEWATER OUTFALL (WO)

	Date	Time	Depth & Time	DO, ppm	Temp., °C	Comments	Methyl Esters 2,4-D ppb	Methyl esters 2,4,5-T ppb	Detection Limit, (units)
Grab Baseline	7-24	0900	7 meters 930	6.2	26.5	Definite sewage odor	ND	ND	0.1 ppb
			7 meters 940						
			7 meters 1340	7.2	26.0	Composited			
			7 meters 1345						
Grab Baseline	7-25	0900	4 meters 910	7.1	26	Composited	ND	ND	0.1 ppb
			4 meters 1240	7.1	26				
Grab Baseline	7-27	0900 1400	6 meters 840	6.8	27	Composited	ND	ND	0.1 ppb
			6 meters 1325	7.2	27				
Grab Baseline	7-29	0900	5 meters 850	--	--	Could smell the sewage in our samples. D.O. meter is still giving improper readings. Composited	ND	ND	0.1 ppb
			7 meters 1350	6.8	27				
Grab Operational	8-1	0900 1400	8 meters 830	6.2	26.5	Composited	ND	ND	0.1 ppb
			8 meters 1315	6.4	28				
Grab Operational	8-3	0900 1800	8 meters 830	7.0	22.5	Water usually clear Composited	ND	Trace	0.1 ppb
			8 meters 1320	6.6	28				
Grab Operational	8-5	0900 1400	8 meters 825	6.5	27.0	Composited	ND	ND	0.1 ppb
			8 meters 1335	5.8	29.0				

	Date	Time	Depth & Time	DO, ppm	Temp., °C	Comments	Methyl Esters 2,4-D ppb	Methyl esters 2,4,5-T ppb	Detection Limit, (units)
Grab	8-17	0800	7 meters 945	7.1	27	Composited	ND	Trace	0.1 ppb
Operational		1400	6 meters 1330	7.3	28				
Grab	8-19	0800	7 meters 830	6.2	28	Composited	ND	ND	0.1 ppb
Operational		1400	7 meters 1332	6.8	28				
Grab	8-22	0800	6 meters 845	5.8	28	Composited	ND	Trace	0.1 ppb
Operational		1400	6 meters 1345	7.3	28				
Grab Post	8-24	0800	7 meters 835	6.8	27	Composited	ND	ND	0.1 ppb
Operational		1400	7 meters 1330	6.5	28				

TABLE 8. WATER SAMPLES SALTWATER INTAKE (WS)

	Date	Time	Depth & Time	DO, ppm	Temp., °C	Comments	Methyl Esters 2,4-D ppb	Methyl Esters 2,4,5-T ppb	Detection Limit, (units)
Grab Baseline	7-24	0800	2 meters 830	7.4	26	Composited	ND	ND	0.1 ppb
			7 meters 850	7.4	26				
	1400	8 meters 1305	7.6	25.5					
		6 meters 1310	8.0	25.5					
	1800	6 meters 1800	7.8	26.0					
		6 meters 1805	7.8	26.0					
Grab Baseline	7-25	0800	6 meters 830	7.8	25	Composited	ND	ND	0.1 ppb
			6 meters 835	7.8	26				
	1400	6 meters 1210	7.9	26					
		6 meters 1215	7.7	26					
	1800	6 meters 1800	7.6	26					
		6 meters 1805	7.6	26.5					
Grab Baseline	7-26	0800	5 meters 815	7.4	25.5	Composited	ND	ND	0.1 ppb
			5 meters 820	7.2	26				
	1400	6 meters 1305	7.3	26.0					
		6 meters 1310	7.2	27.0					
	1800	6 meters 1805	8.0	27.0					
		6 meters 1810	7.6	27.0					
Grab Baseline	7-27	0800	6 meters 810	7.9	26	Composited	ND	ND	0.1 ppb
			5 meters 815	7.7	25				
	1400	6 meters 1305	7.5	27					
		6 meters 1310	7.7	27					
	1800	5 meters 1805	8.4	27					
		5 meters 1810	7.9	26					

TABLE 8. (Continued)

	Date	Time	Depth & Time	DO, ppm	Temp., °C	Comments	Methyl Esters 2,4-D ppb	Methyl Esters 2,4,5-T ppb	Detection Limit, (units)
Grab Operational	7-28	0800	6 meters 810	6.7	26	Composited	ND	Trace	0.1 ppb
			5 meters 815	6.6	26.0				
			5 meters 1305	6.4	27				
			5 meters 1310	6.7	27				
			5 meters 1805	6.8	27.0				
		5 meters 1810	6.7	27.5					
Grab Operational	7-29	0800	5 meters 820	7.1	27	D.O. meter is not operating properly, getting extremely high temperature readings for the second sample (e.g., 40 C). Will let it dry out for 10 min. Composited	ND	ND	0.1 ppb
			5 meters 830	--	--				
			6 meters 1305	7.7	27				
			5 meters 1310	7.6	26.0				
			6 meters 1805	7.5	27				
		5 meters 1810	7.5	27					
Grab Operational	7-30	0800	6 meters 805	7.8	26	Composited	0.53	0.37	0.1 ppb
			6 meters 810	7.4	26.5				
			5 meters 1320	6.8	27.0				
			6 meters 1325	6.8	25.5				
			6 meters 1810	6.8	26.0				
		5 meters 1815	7.1	27.0					
Grab Operational	7-31	0800	6 meters 805	6.6	25.5	Composited	0.515	0.52	0.1 ppb
			5 meters 810	6.8	26.0				
			6 meters 1305	7.2	27				
			5 meters 1310	6.9	26.5				
			6 meters 1805	7.4	26				
		5 meters 1810	7.2	26					

TABLE 8. (Continued)

	Date	Time	Depth & Time	DO, ppm	Temp., °C	Comments	Methyl Esters 2,4-D ppb	Methyl Esters 2,4,5-T ppb	Detection Limit, (units)
Grab Operational	8-1	0800	6 meters 805	6.2	26	Composited	Trace	0.22	0.1 ppb
			5 meters 810	6.4	26.2				
	1400	6 meters 1250	7.0	27.0					
		5 meters 1255	7.1	27.0					
	1800	6 meters 1823	7.2	27					
5 meters 1830	7.1	26.0							
Grab Operational	8-3	0800	6 meters 805	6.9	26.5	Composited	Trace	Trace	0.1 ppb
			5 meters 810	6.9	26.0				
	1400	6 meters 1300	7.2	27.0					
		5 meters 1305	7.3	27.0					
	1800		7.2	27.0					
			7.4	27.0					
Grab Operational	8-4	0800	6 meters 800	6.9	26.0	Composited	Trace	Trace	0.1 ppb
			5 meters 805	6.8	27.0				
	1400	6 meters 1305	7.1	27.0					
		5 meters 1310	7.0	27.2					
	1800	6 meters 1808	7.3	27					
5 meters 1815	7.6	27							
Grab Operational	8-5	0800	6 meters 810	6.7	26.0	Composited	Trace	Trace	0.1 ppb
			5 meters 815	6.4	26.0				
	1400	6 meters 1300	5.8	30.0					
		5 meters 1305	5.8	31.0					
	1800	6 meters 1805	7.2	27					
5 meters 1810	7.1	27							

TABLE 8. (Continued)

	Date	Time	Depth & Time	DO, ppm	Temp., °C	Comments	Methyl Esters 2,4-D ppb	Methyl Esters 2,4,5-T ppb	Detection Limit, (units)
Grab Interim	8-6	0800	6 meters 855	7.7	27.0	Composited	Trace	ND	0.1 ppb
			5 meters 900	7.4	27				
	1400	6 meters 1315	6.8	27.0					
		5 meters 1320	6.5	27.0					
		6 meters 1733	6.5	27.0					
		5 meters 1738	6.5	26					
Grab Interim	8-9		6 meters 805	6.6	26.0	Composited	ND	Trace	0.1 ppb
			5 meters 810	6.8	27.0				
			6 meters 1315	6.8	28				
			5 meters 1320	6.6	28				
			6 meters 1800	7.2	27				
			5 meters 1810	7.4	28				
Grab Interim	8-12		6 meters 820	6.8	27	Composited	ND	Trace	0.1 ppb
			5 meters 825	7.0	26.8				
			6 meters 1305	7.0	27.5				
			5 meters 1310	6.9	27.5				
			6 meters 1825	7.3	22				
			5 meters 1830	7.4	22				
Grab Interim	8-16		6 meters 805	7.4	26.5	Composited	Not analyzed	Not analyzed	0.1 ppb
			6 meters 810	7.6	27				
			6 meters 1310	7.4	27				
			5 meters 1313	7.2	27.5				
				7.6	26.5				
			6 meters 1816	7.4	27				

TABLE 8. (Continued)

	Date	Time	Depth & Time	DO, ppm	Temp., °C	Comments			Detection Limit, (units)
Grab Operational	8-17		6 meters 920	7.6	26	Composited	ND	Trace	0.1 ppb
			5 meters 925	7.6	26				
			6 meters 1300	7.4	27				
			5 meters 1305	7.6	27.5				
			6 meters 1810	7.5	27				
			5 meters 1814	7.7	26				
Grab Operational	8-18		6 meters 810	7.3	26.5	Composited	ND	ND	0.1 ppb
			5 meters 814	7.5	26				
			6 meters 1305	6.8	27				
			5 meters 1308	6.8	28				
			6 meters 1755	7.1	27				
			5 meters 1800	7.0	28				
Grab Operational	8-19		6 meters 805	6.5	27.5	Composited	2.11	1.32	0.1 ppb
			5 meters 807	6.6	28				
			6 meters 1310	6.7	28.5				
			5 meters 1314	6.9	28				
			6 meters 1800	7.4	27				
			5 meters 1805	7.4	28				
Grab Operational	8-20		6 meters 806	6.3	26	Composited	1.05	0.58	0.1 ppb
			5 meters 808	6.3	27				
			6 meters 1312	6.9	26.5				
			5 meters 1316	6.5	26.0				
			6 meters 1750	6.8	28				
			5 meters 1755	6.7	27				

TABLE 8. (Continued)

	Date	Time	Depth & Time	DO, ppm	Temp., °C	Comments			Detection Limit, (units)
Grab Operational	8-21		6 meters 810	7.0	27.5	Composited	ND	Trace	0.1 ppb
			5 meters 814	6.9	28				
			6 meters 1320	6.2	27				
			5 meters 1325	6.9	28				
			6 meters 1748	7.3	27				
			5 meters 1753	7.4	28				
Grab Operational	8-22		6 meters 815	7.0	26	Composited	ND	Trace	0.1 ppb
				6.6	26				
			6 meters 1315	7.1	27				
			5 meters 1318	7.3	27				
			6 meters 1805	7.2	27				
		5 meters 1812	7.4	28					
Grab Operational	8-23		6 meters 809	7.1	26	Composited	ND	ND	0.1 ppb
			5 meters 814	6.9	27.5				
			6 meters 1320	7.2	27				
			5 meters 1325	7.3	28				
			6 meters 1736	7.2	28				
			5 meters 1740	7.1	28				
Grab Post Operational	8-24		6 meters 810	7.3	26	Composited	ND	Trace	0.1 ppb
			5 meters 814	7.4	27				
			6 meters 1308	7.4	28				
			5 meters 1314	7.3	28				
			6 meters 1750	6.7	28				
			5 meters 1756	7.2	28				

TABLE 8. (Continued)

	Date	Time	Depth & Time	DO, ppm	Temp., °C	Comments	2,4-D(Me) ppb	2,4,5-T(Me) ppb	Detection Limit, (units)
Grab Post Operational	8-25	08	6 meters 815	6.8	26	Composited	ND	ND	0.1 ppb
			6 meters 818	6.9	27.5				
			6 meters 1317	7.2	27				
			5 meters 1319	7.2	27				
			6 meters 1740	7.1	27				
		18	5 meters 1745	6.9	27				
Grab Post Operational	8-26	08	6 meters 812	7.2	27	Composited	ND	ND	0.1 ppb
			5 meters 816	6.8	27				
			6 meters 1310	7.1	28				
			5 meters 1315	7.1	27				
			6 meters 1750	7.0	27				
		18	5 meters 1806	7.1	28				

TABLE 9. WHARF (WF)

	Date	Time	Depth & Time	DO, ppm	Temp., °C	Comments	2,4-D(Me) ppb	2,4,5-T(Me) ppb	Detection Limit, (units)
Grab Baseline	7-24	08	8 meters 1015	7.7	25	Composited	ND	ND	0.1 ppb
			10 meters 1020	7.0	—				
			8 meters 1420	7.5	26				
			8 meters 1425	7.2	26				
			9 meters 1815	7.7	26.0				
		18	10 meters 1820	7.6	26.0				
Grab Baseline	7-25	08	10 meters 930	7.8	26.0	Composited; Ship in for 1800 hr sample	ND	ND	0.1 ppb
			10 meters 935	7.6	26.0				
			12 meters 1305	7.6	26.0				
			12 meters 1310	7.6	26.0				
			12 meters 1815	6.4	28.0				
		18	12 meters 1820	7.4	25.0				
Grab Baseline	7-26	08	10 meters 825	7.1	26	Composited	ND	ND	0.1 ppb
			10 meters 830	6.6	27				
			10 meters 1320	7.2	27.5				
			10 meters 1325	7.3	27.0				
			10 meters 1820	7.7	26.0				
		18	10 meters 1815	7.5	27.0				
Grab Baseline	7-27	09	10 meters 900	7.7	26	Composited	ND	ND	0.1 ppb
			10 meters 905	7.6	27				
			10 meters 1350	7.4	27				
			10 meters 1355	7.0	26				
			11 meters 1815	6.8	32				
		18	10 meters 1820	7.0	32				

TABLE 9. (Continued)

	Date	Time	Depth & Time	DO, ppm	Temp., °C	Comments	2,4-D(Me) ppb	2,4,5-T(Me) ppb	Detection Limit, (units)	
Grab Operational	7-28	08	12 meters 820	6.4	26.5	Very small (<1 gal) Spill previous 24 hr; spill confined to wharf Composited	ND	ND	0.1 ppb	
			10 meters 825	6.6	27.0					
			12 meters 1315	6.1	27.0					
			10 meters 1320	6.0	27.0					
			12 meters 1815	6.8	27.0					
		10 meters 1820	6.6	28.0						
Grab Operational	7-29	09	11 meters 910	--	--	Composited	ND	ND	0.1 ppb	
			10 meters 920	--	--					
			14	10 meters 1415	6.7					27
			10 meters 1420	7.1	25					
			18	11 meters 1815	7.4					27
		10 meters 1820	7.3	27						
Grab Operational	7-30	08	10 meters 815	7.2	25	Composited	0.45	0.41	0.1 ppb	
			11 meters 820	7.2	26					
			14	10 meters 1330	6.8					25.5
			11 meters 1335	7.2	25.5					
			18	10 meters 1820	6.8					26.0
		11 meters 1825	6.6	26.5						
Special Grab	7-30	11		6.3	27	Note location off stern and port side- deballasting pumps operating. Comments: ballast wastes orange with black (oily?) trailings; no sheen visible on surface. Looked like rust and bunker oil? Not visible at bow of ship during 1800 hr sampling. Composited	47.57	54.14	0.1 ppb	

TABLE 9. (Continued)

	Date	Time	Depth & Time	DO, ppm	Temp., °C	Comments	2,4-D(Me) ppb	2,4,5-T(Me) ppb	Detection Limit, (units)
Grab Operational	7-31	08	11 meters 815	6.5	26	Composited	Trace	Trace	0.1 ppb
			10 meters 820	6.4	26				
			11 meters 1315	6.8	26				
			10 meters 1320	6.6	26				
			11 meters 1815	7.0	26.2				
		18	10 meters 1820	7.0	26.0				
Grab Operational	8-1	09	11 meters 850	6.0	28.0	Composited	Trace	0.24	0.1 ppb
			10 meters 855	5.8	28.0				
			11 meters 1340	6.8	27.0				
			10 meters 1345	6.6	27.0				
			11 meters	No data--meter not operational					
		18	10 meters						
Grab Operational	8-3	09	11 meters 855	7.0	25.7		ND	Trace	0.1 ppb
			10 meters 900	6.4	27.0				
				6.6	27.5				
				6.6	27.0				
				7.1	27.5				
		18		--	--				
Grab Operational	8-4	08	11 meters 810	6.9	27.0	Small oil spill (10 gal?) at small boat dock. Slick breaking up at 1600 hr; sheen visible over several hundred sq ft; very low winds & enclosed condition will probably allow evaporation. Fish seem unaffect. Composited	Trace	Trace	0.1 ppb
			10 meters 815	6.8	27.0				
			11 meters 1315	6.7	27.0				
			10 meters 1320	6.6	27.0				
			11 meters 1820	6.8	28.0				
			10 meters 1823	6.6	28.0				

TABLE 9. (Continued)

	Date	Time	Depth & Time	DO, ppm	Temp., °C	Comments	2,4-D(Me) ppb	2,4,5-T(Me) ppb	Detection Limit, (units)
Grab Operational	8-5	09	11 meters 850	6.6	27.5	Temperature probe not functioning at 1800 hr sampling. Composited	Trace	Trace	0.1 ppb
			10 meters 855	7.6	24.0				
			11 meters 1350	6.0	29.0				
			10 meters 1355	6.0	29.0				
			11 meters 1815	6.4	--				
10 meters 1820	6.2	--							
Grab Interim	8-6	08	11 meters 905	6.6	27.0	Composited	0.38	0.36	0.1 ppb
			10 meters 910	6.5	27.0				
			11 meters 1323	6.5	27.5				
			10 meters 1328	6.5	27.5				
			11 meters 1740	6.4	27.0				
10 meters 1745	6.3	27.6							
Grab Interim	8-9	08	11 meters 810	6.6	27.0	Composited	Trace	0.28	0.1 ppb
			10 meters 815	6.4	27.2				
			11 meters 1330	6.5	28				
			10 meters 1335	6.4	28.0				
			11 meters 1813	7.1	27.5				
10 meters 1820	7.2	28							
Grab Interim	8-12	08	11 meters 830	7.0	26.0	Composited	ND	Trace	0.1 ppb
			10 meters 835	6.9	26.0				
			11 meters 1315	6.6	27.5				
			10 meters 1320	6.5	27.5				
			11 meters 1835	7.1	21				
10 meters 1838	7.2	22							

TABLE 9. (Continued)

	Date	Time	Depth & Time	DO, ppm	Temp., °C	Comments	2,4-D(Me) ppb	2,4,5-T(Me) ppb	Detection Limit, (units)
Grab Interim	8-16	08	11 meters 812	7.6	26	Composited	Not analyzed	Not analyzed	0.1 ppb
			10 meters 816	7.3	26				
			11 meters 1315	7.2	26				
			10 meters 1320	7.1	27.5				
			10 meters 1830	7.2	27				
			11 meters 1835	7.2	27				
Grab Operational	8-17	08	10 meters 1015	7.5	28	Composited	ND	Trace	0.1 ppb
			10 meters 1018	7.1	28				
			11 meters 1400	7.1	28				
			10 meters 1405	7.0	28				
			11 meters 1820	7.4	27				
			10 meters 1825	7.7	27				
Grab Operational	8-18	08	10 meters 818	7.3	26.0	Meter not operating properly due to moisture: no data for 1800 hours. Composited	ND	ND	0.1 ppb
			11 meters 822	7.3	27				
			11 meters 1314	6.4	28				
			10 meters 1317	6.4	28				
			11 meters 1805	--	--				
			10 meters 1808	--	--				
Grab Operational	8-19	08	10 meters 905	6.4	28	Composited	0.33	0.25	0.1 ppb
			11 meters 910	6.2	28				
			11 meters 1356	6.4	28				
			10 meters 1358	6.6	27				
				7.2	27				
Special Grab, Ballast		10	1000			Taken approximately 10 ft from discharge point.	4698.1	3418.5	0.1 ppb

TABLE 9. (Continued)

	Date	Time	Depth & Time	DO, ppm	Temp., °C	Comments	2,4-D(Me) ppb	2,4,5-T(Me) ppb	Detection Limit, (units)
Grab Operational	8-20	08	11 meters 814	6.7	26.5	No temperature data for 1800 hr due to wet meter. Composited	1.02	0.88	0.1 ppb
			10 meters 817	6.6	27				
			11 meters 1321	7.1	26.0				
			10 meters 1325	6.9	27.5				
			11 meters 1805	6.5					
			10 meters 1810	6.8					
Grab Operational	8-21	08	11 meters 820	6.9	28	Composited	0.28	0.47	0.1 ppb
			10 meters 825	6.4	28				
			11 meters 1335	6.4	28				
			10 meters 1340	6.6	28				
			11 meters 1807	6.9	28				
			10 meters 1809	6.9	28.5				
Grab Operational	8-22	08	11 meters 910	6.9	27				
			10 meters 914	7.0	27				
			10 meters 1412	6.3	28.5				
			11 meters 1417	6.2	28				
			11 meters 1820	6.8	28				
			10 meters 1826	6.5	28				
Grab Operational	8-23	08	10 meters 820	6.9	27	Composited	ND	Trace	0.1 ppb
			11 meters 823	6.8	28				
			11 meters 1331	7.1	28				
			10 meters 1335	7.3	28				
			11 meters 1748	6.7	28				
			10 meters 1753	7.1	28				

TABLE 9. (Continued)

	Date	Time	Depth & Time	DO, ppm	Temp., °C	Comments	2,4-D(Me) ppb	2,4,5-T(Me) ppb	Detection Limit, (units)
Grab Post Operational	8-24	08	10 meters 905	6.9	27	Composited	ND	Trace	0.1 ppb
			11 meters 909	7.0	27				
	14	10 meters 1400	6.8	28					
		11 meters 1405	6.8	28.5					
		10 meters 1808	7.2	28					
Grab Post Operational	8-25	08	11 meters 823	6.8	27	Composited	ND	ND	0.1 ppb
			10 meters 826	6.8	27				
	14	11 meters 1328	7.1	28					
		10 meters 1332	7.1	28					
		11 meters 1756	7.1	26					
Grab Post Operational	8-26	08	11 meters 822	6.8	27	Composited	ND	ND	0.1 ppb
			10 meters 826	6.6	28				
	14	11 meters 1318	6.7	28					
		10 meters 1323	7.0	28					
		11 meters 1814	7.0	28					
18	10 meters 1820	6.9	28						

TABLE 10. SEDIMENTS (S)

Date	Time	Comments	Methyl Esters	Methyl Esters	Detection Limit, (units)
			2,4-D ppb	2,4,5-T ppb	
Baseline					
S1	7-25 1100	Directly off wharf pump area Approximately 1-15 ft out Light west to east Deep current East to west surface current			Shipped to OEHL Kelly AFB for analysis
S2	7-25 1100	Off wharf, west end 10-15 ft out South to north deep current			
Interim					
S1	8-10 1400	As above			As above
S2	8-10 1400	"			"
Post Operational					
S1	8-26 1400	"			"
S2	8-26 1400	"			"

TABLE 11. POTABLE WATER (P1 OR P2)

	Date	Time	Internal	Volume	Start Time	Stop Time	Start (ppm) DO	Start (°C) Temp.	Stop (ppm) DO	Stop (°C) Temp.	Comments	2,4-D(Me) ppb	2,4,5-T(Me) ppb	Detection Limit
Archived (P1)	7-29	00												
Composite Operational (P1) (Composite)	7-30	00	30 min	180 ml	1517	1450	5.6	31.5	5.6	31.5	Composited	ND	Trace	0.1 ppb
Grab-Operational (Grab) (P2)	7-29	15			1500						Single Sample		Not Analyzed	
Grab Operational (Grab) (P2)	7-30	15									Single Sample		Not Analyzed	
Composite Operational (P1)	7-31	15	30 min	180 ml	1500	1517	5.6	31.5	5.6	33	Composited	ND	Trace	0.1 ppb
Archived (P1)	7-30	00			1500		5.6	31.5			Single Sample			
Grab Operational (Grab) (P2)	7-31	15			1505		5.6	33			Single Sample		Not Analyzed	
Composite Operational (P1)	8-1	15	30 min	180 ml	1517	1445	5.6	33	5.6	34	Composited	ND	Trace	0.1 ppb
Composite Operational (P1)	8-2	00	30 min	180 ml	1455	1429	5.6	34	5.0	34	Composited	ND	ND	0.1 ppb
Grab Operational (P2)	8-1	15			1450		5.6	34			Single Sample	ND	ND	0.1 ppb
Composite Operational (P1)	8-3	00	30 min	180 ml	1450	1505	5.0	34	5.1	32.5	Composited	ND	Trace	0.1 ppb

TABLE 11. (Continued)

	Date	Time	Internal	Volume	Start Time	Stop Time	Start (ppm) DO	Start (°C) Temp.	Stop (ppm) DO	Stop (°C) Temp.	Comments	2,4-D(Me) ppb	2,4,5-T(Me) ppb	Derection Limit
Composite Operational (P1)	8-4	00	30 min	180 ml	1510	1447	5.1	32.5	5.1	33	Composited	ND	Trace	0.1 ppb
Composite Operational (P1)	8-5	00	30 min	180 ml	1500	1445			5.1	34	Composited	ND	ND	0.1 ppb
Composite Operational (P1)	8-6	00	30 min	180 ml	1500	1430	5.1	34	4.8	33	Composited; dedrum- ming completed at 2100 hours; 8-5 ship left port at 0830	ND	ND	0.1 ppb
Composite Interim (P1)	8-9	00	30 min	180 ml	1430	1400	7.1	35	5.6	34	Drained container before sampling; composited	ND	Trace	0.1 ppb
Archived (P1)	8-9	00									Single Sample			
Composite Interim (P1)	8-12	00	30 min	180 ml	1430	1415	5.0	31.5	4.1	30.5	Composited	ND	ND	0.1 ppb
Archived (P1)	8-12	00									Composited			
Composite Interim (P1)	8-16	00	30 min	180 ml	1435	1410	5.6	35	5.6	35	Composited	Not Analyzed	Not Analyzed	0.1 ppb
Composite Operational (P1)	8-17	00	30 min	180 ml	1420	1430	5.6	35	6.1	34	Composited	ND	Trace	
Composite Operational (P1)	8-18	00	30 min	180 ml	1440	1445	6.1	34	5.4	35	Composited	ND	Trace	0.1 ppb

TABLE 11. (Continued)

	Date	Time	Internal	Volume	Start Time	Stop Time	Start (ppm) DO	Start (°C) Temp.	Stop (ppm) DO	Stop (°C) Temp.	Comments	2,4-D(Me) ppb	2,4,5-T(Me) ppb	Detection Limit
Composite Operational (P1)	8-19	00	30 min	180 ml	1500		5.4	35	5.5	34.5	Composited	ND	Trace	0.1 ppb
Composite Operational (P1)	8-20	00	30 min	180 ml	1455	1440	5.5	34.5	5.4	33	Composited	ND	Trace	0.1 ppb
Composite Operational (P1)	8-21	00	30 min	180 ml	1448	1425	5.4	33	5.6	34	Composited	ND	Trace	0.1 ppb
Composite Operational (P1)	8-22	00	30 min	180 ml	1435	1440	5.6	34	5.2	34	Composited	ND	Trace	0.1 ppb
Composite Operational (P1)	8-23	00	30 min	180 ml	1452	1432	5.2	34	4.9	34	Composited	ND	Trace	0.1 ppb
Composite Post-Operational (P1)	8-24	00	30 min	180 ml	1440	1435	4.9	34	5.2	33	Composited	ND	ND	0.1 ppb
Archived (P1)	8-24	00									Composited	--	--	
Composite Post-Operational (P1)	8-25	00	30 min	180 ml	1445	1430	5.2	33	5.3	32	Composited	ND	ND	0.1 ppb
Archived (P1)	8-25	00									Composited			
Composite Post-Operational (P1)	8-26	00	30 min	180 ml	1440	1510	5.3	32	5.4	31	Composited	ND	ND	0.1 ppb
Archived (P1)	8-26	00									Composited	--	--	

TABLE 12. SEWAGE (SE)

	Date	Time	Internal	Volume	Start Time	Stop Time	Start (ppm) DO	Start (°C) Temp.	Stop (ppm) DO	Stop (°C) Temp.	Comments	2,4-D(Me) ppb	2,4,5-T(Me) ppb	Detection Limit
Composite Baseline (SE 1)	7-26	00	30 min	150 ml	1050	1040	0.9	31	1.2	34	Sampler took three small samples (3,4,5); ice OK (at 1530); increased volume (1930); some a.m. bottles low; proportioned composite	ND	ND	0.1 ppb
Composite Volumes a.m. 59% (11 a.m.- 11 p.m.) p.m. 41% (11 p.m.- 11 a.m.)														
Grab-Baseline (Back-up) (SE 2)	7-25	10			1100		0.9	31			Single Sample		Not Analyzed	
Grab-Baseline (Back-up) (Se 2)	7-26	12			1230		1.2	34			Single Sample		Not Analyzed	
Composite Operational (SE 1)	7-28	00	30 min	180 ml	1040	1110	1.2	34	0.6	33	Composited	8.93	13.09	0.1 ppb
Grab-Baseline (Back-up) (SE 2)	7-27	1040									Single Sample		Not Analyzed	
Composite Operational (SE 1)	7-30	00	30 min	180 ml	1155	1245	1.4	33	1.1	35	Could not enter Red Hot area at 1100 hrs; composited	20.65	19.01	0.1 ppb
Composite Operational (SE 2)	7-28	11			1150		0.6	33			Single Sample		Not Analyzed	
Grab Operational (Grab) (SE 2)	7-29	12			1158		1.4	33			Single Sample; Note: no loading 1800 hours on 7-29 to 1900 hours on 7-30	22.81	27.23	0.1 ppb

TABLE 12. (Continued)

	Date	Time	Internal	Volume	Start Time	Stop Time	Start (ppm) DO	Start (°C) Temp.	Stop (ppm) DO	Stop (°C) Temp.	Comments	2,4-D(Me) ppb	2,4,5-T(Me) ppb	Detection Limit
Grab Operational (Grab) (SE 2)	7-30	12			1230		1.1	35			Single Sample		Not Analyzed	
Composite Operational (SE 1)	8-2	00	30 min	120 ml	1057	1305	1.0	33	0.7	35	Composited	12.39	11.77	0.1 ppb
Composite Operational (SE 1)	8-4	00	30 min	120 ml	1045	1105	0.7	32	0.4	35.5	Composited	46.60	47.16	0.1 ppb
Composite Operational (SE 1)	8-6	00	30 min	120 ml	1105	1045	1.0	32.0	0.7	35	Composited	65.63	72.15	0.1 ppb
Composite Interim (SE 1)	8-9	00	30 min	120 ml	945	940	1.4	32	0.8	35	Composited	20.35	21.76	0.1 ppb
Composite Interim (SE 1)	8-12	00	30 min	120 ml	935	910	0.2	33	0.4	33	Composited	12.26	13.59	0.1 ppb
Composite Interim	8-16	00	30 min	120 ml	1005	1015	0.8	31	3.1	33	Composited	Not Analyzed	Not Analyzed	0.1 ppb
Composite Operational	8-18	00	30 min	180 ml	1515	1520	1.2	34	0.4	35	Composited	53.17	55.89	0.1 ppb
Composite Operational	8-20	00	30 min	180 ml	945	1005	2.1	35	0.9	34	Composited	28.95	16.32	0.1 ppb
Composite Operational	8-23	00	30 min	180 ml	940	1010	0.4	34	1.1	33	Composited	29.60	29.16	0.1 ppb

42

TABLE 12. (Continued)

	Date	Time	Internal	Volume	Start Time	Stop Time	Start (ppm) DO	Start (°C) Temp.	Stop (ppm) DO	Stop (°C) Temp.	Comments	2,4-D(Me) ppb	2,4,5-T(Me) ppb	Detection Limit
Composite Post-Operational	8-25	00	30 min	180 ml	1000	1000	1.1	34.5	0.4	34	Composited	3.88	2.83	0.1 ppb
Composite Post-Operational	8-26	00	30 min	180 ml	1015	1035	0.4	34	0.8	33	Composited	1.42	0.89	0.1 ppb

TABLE 13. ORANGE HERBICIDE CONCENTRATIONS IN WATER AT VARIOUS LOCATIONS
AROUND JOHNSTON ISLAND (1973-1977) (a)

Location ^(b)	No. Samples	No. Positive		No. Trace		No. Not Detected		Average		Positive Average		Maximum	
		2,4-D	2,4,5-T	2,4-D	2,4,5-T	2,4-D	2,4,5-T	ng/l (ppt)					
		2,4-D	2,4,5-T	2,4-D	2,4,5-T	2,4-D	2,4,5-T	2,4-D	2,4,5-T	2,4-D	2,4,5-T		
Control ^(c)	75	2	1	2	3	71	71	8.01	1.07	301	80	541	80
Wharf (WF)	52	3	2	3	1	46	49	18.10	8.25	314	215	544	293
Southside (WO)	22	1	2	3	1	18	19	1.50	2.23	33	24	33	34
Shoreline Herb. area (WD)	76	25	28	12	12	38	36	129	67	393	182	2980	581
Saltwater intake (WS)	74	3	4	3	6	67	64	39	12	952	227	2310	650
Distillation plant (Pl)	75	0	0	8	11	66	64	0	0	--	--	--	--
0.5 MG reservoir	24	4	7	2	2	18	15	24	84	143	288	179	288
0.2 MG reservoir	19	2	1	1	1	15	16	1.6	1.6	170	30	240	30

(a) Analyzed by OEHL Kelly AFB, TX.

(b) Nearest Pacer HO sampling site indicated in parenthesis

(c) Offshore area near the golf course.

TABLE 14. TIDE AT JOHNSTON ISLAND, JULY, 1977

Times Corrected for Johnston Island			
7 L 0451 -0.1	15 L 0011 0.2	22 L 0358 -0.1	30 L 0029 0.0
th H 1155 1.7	F H 0451 1.3	F H 1055 1.9	SA H 0525 1.5
L 1710 0.2	L 1013 -0.1	L 1626 0.6	L 1051 0.0
H 2232 1.7	H 1736 2.7	H 2156 1.8	H 1759 2.8
8 L 0539 -0.1	16 L 0043 0.1	23 L 0443 -0.1	31 L 0052 0.0
F H 1304 1.9	SA H 0531 1.3	SA H 1211 2.1	SU H 0618 1.6
L 1902 0.7	L 1048 -0.1	L 1820 0.7	L 1139 -0.1
H 2324 1.5	H 1808 2.7	H 2252 1.6	H 1838 2.7
9 L 0617 -0.1	17 L 0113 0.1	24 L 0537 -0.1	AUGUST
SA H 1400 2.1	SU H 0613 1.4	SU H 1311 2.3	1 L 0124 0.0
L 2035 0.6	L 1126 0.0	L 2003 0.6	M H 0706 1.6
10 H 0030 1.4	H 1838 2.6	--	L 1226 0.1
SU L 0702 -0.1	18 L 0138 0.1	25 H 0011 2.4	H 1911 2.5
H 1444 2.3	M H 0656 1.4	M L 0633 0.0	MOON PHASES
L 2147 0.5	L 1208 0.1	→ H 1415 2.5	1st QTR 23/0838 AM
11 H 0136 1.3	H 1911 2.5	L 2118 0.4	Full 30/0052 AM
M L 0741 -0.1	19 L 0209 0.0	26 H 0.31 2.3	Last QTR 7/1839 PM
H 1524 2.4	TU H 0745 1.5	L 0729 0.0	New 15/1037 PM
L 2229 0.4	L 1253 0.2	H 1508 2.7	
12 H 0235 1.3	H 1943 2.4	L 2214 0.3	
TU L 0823 -0.1	20 L 0241 0.0	27 H 0244 2.3	
H 1601 2.5	W H 0837 1.6	W L 0824 0.0	
L 2307 0.3	L 1346 0.3	H 1555 2.9	
13 H 0327 1.3	H 2020 2.2	L 2256 0.1	
W L 0902 -0.1	21 L 0317 0.0	28 H 0343 2.4	
H 1634 2.6	H 0943 1.6	TH L 0916 -0.1	
L 2340 0.2	L 1455 0.5	H 1639 2.9	
14 H 0412 1.3	H 2101 2.0	L 2338 0.0	
TH L 0937 -0.1	29 H 0438 2.4	29 H 0438 2.4	
H 1707 2.7	F L 1002 0.0	F L 1002 0.0	
	H 1720 2.9	H 1720 2.9	

TABLE 14. (Continued) (AUGUST, 1977)

Times Corrected for Johnston Island			
1	L 0124 0.0	9	H 0117 1.3
M	H 0706 1.6	TU	L 0708 0.1
	L 1226 0.1		H 1451 2.4
	H 1911 2.5		L 2157 0.4
2	L 0159 0.0	10	H 0223 1.3
TU	H 0750 1.7	W	L 0758 0.1
	L 1314 0.2		H 1530 2.5
	H 1947 2.3		L 2232 0.3
3	L 0231 0.0	11	H 0315 1.4
W	H 0846 1.8	TH	L 0842 0.0
	L 1408 0.4		H 1606 2.6
	H 2022 2.1		L 2301 0.3
4	L 0306 0.1	12	H 0356 1.5
TH	H 0946 1.8	F	L 0925 0.0
	L 1514 0.6		H 1638 2.6
	H 2057 1.8		L 2326 0.2
5	L 0345 0.1	13	H 0438 1.5
F	H 1056 1.9	SA	L 1006 0.0
	L 1644 0.7		H 1720 2.7
	H 2139 1.7		L 2354 0.2
6	L 0428 0.1	14	H 0523 1.6
SA	H 1207 2.0	SU	L 1042 0.0
	L 1337 0.7		H 1739 2.6
	H 2235 1.5		
7	L 0517 0.1	15	L 0020 0.1
SU	H 1313 2.2	M	H 0552 1.7
	L 2016 0.7		L 1124 0.1
	H 2354 1.4		H 1821 2.5
8	L 0614 0.1	16	L 0047 0.1
M	H 1406 2.3	TU	H 0634 1.8
	L 2118 0.5		L 1209 0.1
			H 1842 2.4
17	L 0125 0.0	17	L 0125 0.0
	H 0729 1.9	W	H 0729 1.9
	L 1255 0.3		L 1255 0.3
	H 1915 2.2		H 1915 2.2
25	H 0252 1.5	25	H 0252 1.5
	L 0819 0.0	TH	L 0819 0.0
	H 1535 2.8		H 1535 2.8
	L 2227 0.1		L 2227 0.1
18	L 0152 0.0	18	L 0152 0.0
	H 0822 2.0	TH	H 0822 2.0
	L 1351 0.4		L 1351 0.4
	H 1953 2.1		H 1953 2.1
26	H 0345 1.6	26	H 0345 1.6
	L 0915 0.0	F	L 0915 0.0
	H 1617 2.8		H 1617 2.8
	L 2302 0.1		L 2302 0.1
19	L 0223 0.0	19	L 0223 0.0
	H 0910 2.1	F	H 0910 2.1
	L 1501 0.6		L 1501 0.6
	H 2032 1.8		H 2032 1.8
27	H 0431 1.7	27	H 0431 1.7
	L 1003 0.0	SA	L 1003 0.0
	H 1657 2.7		H 1657 2.7
	L 2334 0.1		L 2334 0.1
20	L 0305 0.0	20	L 0305 0.0
	H 1020 2.2	SA	H 1020 2.2
	L 1638 0.7		L 1638 0.7
	H 2127 1.6		H 2127 1.6
28	H 0515 1.8	28	H 0515 1.8
	L 1052 0.0	SU	L 1052 0.0
	H 1735 2.6		H 1735 2.6
21	L 0355 0.0	21	L 0355 0.0
	H 1136 2.3	SU	H 1136 2.3
	L 1831 0.6		L 1831 0.6
	H 2240 1.5		H 2240 1.5
29	L 0009 0.1	29	L 0009 0.1
	H 0555 1.9	M	H 0555 1.9
	L 1137 0.1		L 1137 0.1
	H 1807 2.4		H 1807 2.4
22	L 0458 0.1	22	L 0458 0.1
	H 1248 2.4	M	H 1248 2.4
	L 2003 0.5		L 2003 0.5
30	L 0034 0.1	30	L 0034 0.1
	H 0637 2.0	TU	H 0637 2.0
	L 1223 0.2		L 1223 0.2
	H 1840 2.3		H 1840 2.3
23	H 0019 1.4	23	H 0019 1.4
	L 0607 0.1	TU	L 0607 0.1
	H 1351 2.6		H 1351 2.6
	L 2103 0.4		L 2103 0.4
31	L 0100 0.1	31	L 0100 0.1
	H 0729 2.1	W	H 0729 2.1
	L 1320 0.3		L 1320 0.3
	H 1911 2.1		H 1911 2.1
24	H 0145 1.4	24	H 0145 1.4
	L 0716 0.0	W	L 0716 0.0
	H 1447 2.7		H 1447 2.7
	L 2152 0.2		L 2152 0.2

Moon Phases

First Quarter: 21st 1504
 Last Quarter: 6th 1040

Full Moon: 28th 1010
 New Moon: 14th 1131

TABLE 15. VASCULAR PLANTS KNOWN FROM JOHNSTON ATOLL

Family Species Common Name	Islands				Sand Man- made
	Akau	Hikina	John- ston	Sand Orig.	
Polypodiaceae Ferns					
<i>Polypodium scolopendria</i>					
<i>Nephrolepis</i> sp.	A				
Araucariaceae					
<i>Araucaria heterophylla</i>			P		
Norfolk Island pine					
Pandaneaceae					
<i>Pandanus tectorius?</i>			P		
Screw-pine, hala					
Gramineae Grasses			A	A	A
<i>Cenchrus chinatus</i>					
Sandbur					
<i>Chloris barbata</i>			A		
Fingergrass					
<i>Cynodon dactylon</i>	A		P	A	P
Bermuda grass					
<i>Dactyloctenium aegyptium</i>	A		A	A	A
Crowfoot grass					
<i>Digitaria sanguinalis</i>					A
Crabgrass					
<i>Echinochloa crus-galli</i>			A		
Barnyard grass					
<i>Eleusine indica</i>	A	A	A	A	A
Goose grass					
<i>Eragrostis tenella</i>	A		A		
(incl. <i>amabilis</i>)					
Lovegrass					
<i>Lepturus repens</i>		A	N	N	A
Bunch grass					

A = Adventive; N = Native; P = Planted; S = Seed only
 Source: Amerson and Shelton, 1976.

TABLE 15. (Continued)

Family Species Common Name	Islands				
	Akau	Hikina	John- ston	Sand Orig.	Sand Man- made
Gramineae(cont.)					
<i>Paspalum dilatatum</i> Dallas grass			A		
<i>Saccharum officinarum</i> Sugarcane			P		
<i>Setaria verticillata</i> Bristlegrass			A	A	A
<i>Sporobolus virginicus</i> Dropseed			A		
<i>Zea mays</i> Corn	P				
Cyperaceae Sedges					
<i>Cyperus rotundus</i>			A		
<i>Fimbristylis cymosa?</i>	A	A	A		A
Palmae Palms					
<i>Cocos nucifera</i> Coconut palm	P	P	P		P
Araceae					
<i>Anthurium andracanum</i> Anthurium			P		
Liliaceae					
<i>Allium fistulosum</i> Welsh onion			P		
<i>Allium</i> sp. Chives			P		
<i>Aloe</i> sp. Aloe					P
<i>Cordyline fruticosa</i> Cordyline			P		
<i>Sansevieria trifasciata</i> Bowstring Hemp			P		

TABLE 15. (Continued)

Family Species Common Name	Islands				Sand Man- made
	Akau	Hikina	John- ston	Sand Orig.	
Amaryllidaceae					
<i>Crinum asiaticum</i>			P		
<i>Crinum</i> sp.	P		P		P
<i>Hymenocallis littoralis</i> Spider lily	P		P		P
Bromeliaceae					
<i>Ananas comosus</i>					P
Zingiberaceae					
<i>Alpina</i> sp. Ginger			P		
Musaceae					
<i>Heliconia humilis</i>			P		
<i>Strelitzia reginae</i> Bird of Paradise			P		
Orchidaceae Orchids					
<i>Epidendrum</i> sp.			P		
<i>Vanda</i> sp.			P		
Casuarinaceae					
<i>Casuarina equisetifolia</i> Ironwood	P		P		P
Moraceae					
<i>Ficus microcarpa</i> Banyan		P	P		P
Urticaceae					
<i>Pilea microphylla</i> Artillery plant					A
Polygonaceae					
<i>Coccoloba wifera</i> Sea-grape	P		P		P
Chenopodiaceae					
<i>Chenopodium murale</i> Goosefoot, Pigweed			A	A	A
Amaranthaceae Pigweeds					
<i>Amaranthus dubius</i>			A	A	A

TABLE 15. (Continued)

Family Species Common Name	Islands				Sand Man- made
	Akau	Hikina	John- ston	Sand Orig.	
Amaranthaceae (cont.)					
<i>A. spinosus</i>			A		
<i>A. viridis</i>	A		A	A	A
Nyctaginaceae					
<i>Boerhavia</i> sp.	A		N	N	A
<i>Bougainvillea</i> sp.			P		P
Aizoaceae					
<i>Tetragonia tetragonioides</i> New Zealand Spinach					P
<i>Sesuvium portulacastrum</i>	A	A	A	A	A
Portulacaceae					
<i>Portulaca oleracea</i> Purslane	A	A	A	A	A
Caryophyllaceae					
<i>Spergularia marina</i>	A	A	A	A	A
Lauraceae					
<i>Persea americana</i> Avocado			P		P
Cruciferae					
<i>Lobularia maritima</i> Sweet Alyssum			P		A
Rosaceae					
<i>Eriobotrya japonica</i> Loquat					P
Leguminosae					
<i>Acacia farnesiana</i> Sweet Acacia	A		A		
<i>Crotalaria incana</i> Rattlebox			A		
<i>Leucaena latisiliqua</i>			A		A
<i>Phaseolus</i> sp. Bean	P				

TABLE 15. (Continued)

Family Species Common Name	Islands				Sand Man- made
	Akau	Hikina	John- ston	Sand Orig.	
Leguminosae (cont.)					
<i>Pisum sativum</i> Pea	P				
<i>Mucuna</i> sp.		S		S	
<i>Pithecellobium dulce</i> Manila Tamarind			P		
<i>Prosopis pallida</i> Algarobe, Kiawe			S		
<i>Vigna marina</i> Beach pea	A		A	A	
Zygophyllaceae					
<i>Tribulus cistoides</i> Puncture Vine			N	N	A
Ruthaceae					
<i>Citrus aurantifolia</i> Lime			P		
<i>Citrus sinensis</i> Orange	A				
Euphorbiaceae					
<i>Aleurites moluccana</i> Candlenut, Kukui		S		S	
<i>Codiaeum variegatum</i> var. <i>pictum</i> Croton	P		P		P
<i>Euphorbia atoto?</i> Spurge			A		
<i>E. prostrata</i> Spurge			A		
<i>E. prob. heterophylla</i> Spurge			A		

TABLE 15. (Continued)

Family Species Common name	Islands			Sand Man- made
	Akau	Hikina	John- ston	
Euphorbiaceae (cont.)				
<i>E. glomerifera</i> Spurge	A		A	A
<i>E. hirta</i> Spurge			A	A
<i>E. pulcherrima</i> Poinsettia			P	P
<i>Pedilanthus tithymeloides</i> Slipper flower			P	
<i>Ricinus communis</i> Castor bean			A	
Anacardiaceae				
<i>Mangifera indica</i> Mango	P		P	
<i>Schinus terebinthifolius</i> Christmas berry tree			P	
Tiliaceae				
<i>Triunfetta procumbens</i>			P	
Malvaceae				
<i>Hibiscus tiliaceus</i> Hau			P	
<i>Hibiscus</i> sp.			P	P
<i>Thespesia populnea</i> Milo tree, Portia tree			A	
<i>Sida</i> sp.			?	
Sterculiaceae				
<i>Waltheria indica</i>			A	
Guttiferae				
<i>Calophyllum inophyllum</i> False Kamani	P		P	

TABLE 15. (Continued)

Family Species Common Name	Islands				Sand Man- made
	Akau	Hikina	John- ston	Sand Orig.	
Combretaceae					
<i>Terminalia catappa</i> Indian almond, Kamani		S	P	S	P
Myrtaceae					
<i>Eucalyptus</i> sp.					
Araliaceae					
<i>Brassaia actinophylla</i> Octopus tree			P		
<i>Polyscias guilfoylei</i> Wild coffee			P		
Caricaceae					
<i>Carica papaya</i> Papaya			P		
Plumbaginaceae					
<i>Plumbago auriculata</i> Plumbago, leadwort			P		
Apocynaceae					
<i>Catharanthus roseus</i> Madagascar Periwinkle			P		
<i>Nerium oleander</i> Oleander			P		P
<i>Plumeria acuminata</i> Frangipani			P		
<i>Plumeria rubra</i> Frangipani	P		P		
<i>Thevetia peruviana</i> var. <i>aurantiaca</i>			P		
<i>T. peruviana</i> (= <i>nereifolia</i>) Yellow Oleander			P		
Convolvulaceae					
<i>Ipomoea indica</i>				A	

TABLE 15. (Continued)

Family Species Common Name	Islands				Sand Man- made
	Akau	Hikina	John- ston	Sand Orig.	
Convolvulaceae (cont.)					
<i>I. pes-caprae</i> Beach Morning Glory			A	A	A
<i>I. macrantha</i>			?		
<i>Merremia tuberosa</i> Wood Rose			P		
Hydrophyllaceae					
<i>Nama sandwicensis</i>			A		
Boraginaceae					
<i>Cordia sebestena</i> Kou, Geiger-Tree			P		P
<i>Heliotropium curassavicum</i>			A	A	A
<i>Tournefortia argentea</i> Tree Heliotrope		P	P	P	P
Verbenaceae					
<i>Stachytarpheta jamaicensis</i>			A		
<i>Vitex ovata</i>	P		P		
Solanaceae					
<i>Capsicum frutescens</i> Papper	P		P		
<i>Nicotiana glauca</i>			A		
<i>Solanum lycopersicum</i> Tomato	P?	P?	P		P?
<i>Solanum melogena</i> Eggplant			P		
Bignoniaceae					
<i>Tabeluia pentophylla</i> West Indian Boxwood			P		
Rubiaceae					
<i>Gardenia</i> sp.			P		
<i>Coprosma</i> sp.			P		

TABLE 15. (Continued)

Family Species Common Name	Islands				
	Akau	Hikina	John- ston	Sand Orig.	Sand Man- made
Cucurbitaceae					
<i>Citrullus lanatus</i> var. <i>vulgaris</i> Watermelon	P		P		
<i>Cucumis melo</i> Muskmelon	P				
Goodeniaceae					
<i>Scaevola taccada</i>			P	P	P
Compositae					
<i>Bidens pilosa</i> Burmarigold			A		
<i>Coryza bonariensis</i>	A	A	A		
<i>Emilia sonchifolia</i>			A		
<i>Helianthus annuus</i> Sunflower			P		
<i>Pluchea indica</i>	A	A		A	
<i>Pluchea carolinensis</i>	A	A	A	A	A
<i>Pluchea</i> × <i>Fosbergii</i>			A		
<i>Sonchus</i> sp. (<i>oleraceus</i> × <i>asper</i>)? Scw-thistle			A	A	A
<i>Tagetes</i> sp. Marigold	P		P		
<i>Vernonia cinerea</i> Ironweed			A		A
<i>Zinnia elegans</i> Zinnia	P		P		

TABLE 16. INSECTS RECORDED FROM JOHNSTON ATOLL; ADAPTED FROM CHILSON (1953)

Orthoptera
Blattidae
<i>Blattella lituricollis</i> (Walker)
<i>Cutilla soror</i> (Brunner)
<i>Periplaneta americana</i> (Linnaeus)
<i>Pyrenocelus surinamensis</i> (Linnaeus)
Dermaptera
Labiduridae
<i>Anisolabis maritima</i> (Gene)
<i>Euhorellia annulipes</i> (Lucas)
Mallophaga
Menoponidae
<i>Austromenopon sternophilum</i> (Ferris); on tern.
Thysanoptera
Aeolothripidae
<i>Frankliniella culfurea</i> Schmutz
Hemiptera
Lygacidae
<i>Nysius terrestris</i> Usinger
<i>Geocoris punctipes</i> (Say)
Reduviidae
<i>Zelus renardii</i> Kolenati
Nabidae
<i>Nabis capsiformis</i> Germar
Gerridae
<i>Halobates sericeus</i> Eschscholtz
Homoptera
Aphididae
<i>Aphis gossypii</i> Glover
<i>Aphis medicaginis</i> Koch
Margarodidae
<i>Icerya purchasi</i> Maskell
Pseudococcidae
<i>Pseudococcus</i> (<i>citri</i> complex)
<i>Pseudococcus</i> sp. perhaps <i>citri</i> (Risso)
<i>Ferrisia virgata</i> (Cockerell)

Source: Amerson and Shelton, 1976.

TABLE 16. (Continued)

Homoptera (cont.)

Coccidae

Coccus sp.*Coccus hesperidum* Linnaeus*Saissetia nigra* (Nietner)*Saissetia oleae* (Bernard)

Diaspididae

Aspidiotus lataniae Signoret*Chrysomphalus dictyospermi* (Morgan)*Pinnaspis* sp.*Pinnaspis strachani* (Cooley) (of Ferris and Rao)

Neuroptera

Hemerobiidae

Symphorobius sp. may be *barberi* Banks

Lepidoptera

Tineidae

Tineola uterella Walsingham*Ereunetis incerta* Swezey

Pterophoridae

Trichoptilus oxydactylus (Walker)

Phalaenidae

Achaea janata (Linnaeus)*Laphygma exempta* (Walker)

Coleoptera

Dermestidae

Dermestes ater Degeer

Histeridae

Carcinops quattuordecimstriata (Stephens)

Anobiidae

Lasioderma serricorne (Fabricius)

Tenebrionidae

Alphitobius piceus (Oliver)

Coccinellidae

Coelophora inaequalis (Fabricius)*Scymnus loewii* Mulsant*Scymnus notescens* Blackburn

Curculionidae

Dryotribus mimeticus Horn*Macranycylus immigrans* (Perkins)

Hymenoptera

Encyrtidae

Aenasius advena Compere*Leptomastix dactylopii* Howard

Formicidae

Solenopsis geminata rufa (Jerdon)*Monomorium pharaonis* (Linnaeus)*Cardiocondyla* sp.*Tetramorium guineense* (Fabricius)*Paratrechina* (*Nylanderia*) sp.*Paratrechina longicornis* (Latreille)

TABLE 16. (Continued)

Hymenoptera (cont.)

Sphecidae

Chalybion bengalense (Dahlbom)

Vespidae

Polistes fuscatus aurifer Saussure

Megachilidae

Megachile fullaxyi Cockerell

Diptera

Syrphidae

Simosyrphus (Xanthogramma) grandicornis (Macquart)*Xanthogramma scutellaris* (Fabricius)*Syrphus* sp.

Sarcophagidae

Goniophyto bryani Lopes*Sarcophaga* sp.*Sarcophaga dux* Thomson*Sarcophaga barbata* Thomson

Calliphoridae

Phaenicia sp.

Muscidae

Musca domestica Linnaeus*Musca domestica vicina* Macquart*Atherigona excisa* (Thomson)

Milichiidae

Desmometopa sp.

Agromyzidae

Agromyze pusilla Meigen

Hippoboscidae

Olfersia spinifera (Leach); from frigate birds.

TABLE 17. BIRDS FROM JOHNSTON ATOLL**

Order Procellariiformes	
Family Diomedidae	
<i>Diomedea nigripes</i> *	Black-footed Albatross
<i>Diomedea immutabilis</i> *	Laysan Albatross
Family Procellariidae	
<i>Pterodroma alba</i> *	Phoenix Petrel
<i>Bulweria bulwerii</i>	Bulwer's Petrel
<i>Puffinus pacificus</i>	Wedge-tailed Shearwater
<i>Puffinus nativitatis</i>	Christmas Shearwater
<i>Puffinus puffinus newelli</i> *	Newell's Shearwater
Family Hydrobatidae	
<i>Oceanodroma tristrami</i> *	Sooty Storm Petrel
Order Pelecaniformes	
Family Phaethontidae	
<i>Phaethon aethereus</i> *	Red-billed Tropicbird
<i>Phaethon rubricauda</i>	Red-tailed Tropicbird
<i>Phaethon lepturus</i> *	White-tailed Tropicbird
Family Sulidae	
<i>Sula dactylatra</i> *	Blue-faced Booby
<i>Sula leucogaster</i>	Brown Booby
<i>Sula sula</i>	Red-footed Booby
Family Fregatidae	
<i>Fregata minor</i>	Great Frigatebird
<i>Fregata ariel</i> *	Lesser Frigatebird
Order Ciconiiformes	
Family Ardeidae	
<i>Bubulcus ibis</i> *	Cattle Egret
Order Anseriformes	
Family Anatidae	
<i>Anas acuta</i> *	Pintail
<i>Anas [=Mareca] americana</i> *	American Wigeon
<i>Anas [=Spatula] clypeata</i> *	Northern Shoveler
Order Galliformes	
Family Phasianidae	
<i>Gallus gallus</i>	Domestic Chicken
Order Falconiformes	
Family Falconidae	
<i>Falco peregrinus tundrius</i> *	Peregrine Falcon

Source: Amerson and Shelton, 1976.

TABLE 17. (Continued)

Order Charadriiformes	
Family Charadriidae	
<i>Pluvialis dominica</i> *	American Golden Plover
<i>Pluvialis [=Squatarola] squatarola</i> *	Black-bellied Plover
<i>Charadrius semipalmatus</i> *	Semipalmated Plover
Family Scolopacidae	
<i>Numenius tahitiensis</i> *	Bristle-thighed Curlew
<i>Tringa [=Totanus] flavipes</i> *	Lesser Yellowlegs
<i>Actitis macularia</i> *	Spotted Sandpiper
<i>Catoptrophorus semipalmatus</i> *	Willet
<i>Heterosceclus incanus [=incanum]</i> *	Wandering Tattler
<i>Arenaria interpres</i> *	Ruddy Turnstone
<i>Limnodromus</i> sp.*	Dowitcher species
<i>Calidris [=Crocethia] alba</i> *	Sanderling
<i>Calidris [=Ereunetes] mauri</i> *	Western Sandpiper
<i>Calidris [=Erolia] melanotos</i> *	Pectoral Sandpiper
<i>Calidris [=Erolia] acuminata</i> *	Sharp-tailed Sandpiper
<i>Tryngites subruficollis</i> *	Buff-breasted Sandpiper
<i>Philomachus pugnax</i> *	Ruff
Family Phalaropodidae	
<i>Steganopus tricolor</i> *	Wilson's Phalarope
Family Laridae	
<i>Larus glaucescens</i> *	Glaucous-winged Gull
<i>Larus argentatus</i> *	Herring Gull
<i>Larus atricilla</i> *	Laughing Gull
<i>Larus pipixcan</i> *	Franklin's Gull
<i>Larus</i> spp.*	Gull species
<i>Sterna lunata</i>	Gray-backed Tern
<i>Sterna fuscata</i>	Sooty Tern
<i>Thalasseus elegans</i> *	Elegant Tern
<i>Procelsterna cerulea</i> *	Blue-gray Noddy
<i>Anous stolidus</i>	Brown Noddy
<i>Anous tenuirostris</i>	Black Noddy
<i>Gygis alba</i>	White Tern
Order Columbiformes	
Family Columbidae	
<i>Columba livia</i>	Rock Dove
Order Strigiformes	
Family Strigidae	
<i>Asio flammeus</i> *	Short-eared Owl
Order Passeriformes	
Family Alaudae	
<i>Alauda arvensis</i> *	Skylark
Family Zosteropidae	
<i>Zosterops japonica</i> *	Japanese White-eye
Family Estrildidae	
<i>Lonchura striata</i>	Society Finch

**Resident birds are unmarked; non-resident birds are marked with an *.

TABLE 18. STATUS OF BIRDS ON JOHNSTON ATOLL

	Akau	Hikina	Johnston	Sand	
				Original	Man-made
<u>Seabirds:</u>					
<u>Breeders</u>					
Bulwer's Petrel			b	B	B
Wedge-tailed Shearwater			B	B	B
Christmas Shearwater			b	B	
Red-tailed Tropicbird			B	B	B
Brown Booby	?	?	b	B	b
Red-footed Booby			b	B	b
Great Frigatebird	R	R	b	B	b
Gray-backed Tern	B*	B**	b	B	b
Sooty Tern			b	B	b
Brown Noddy	?	B*	bR	B	b
Black Noddy			B**	B	r
White Tern			B	R	R
<u>Former Breeders</u>					
Black-footed Albatross				bR	
Laysan Albatross			b	R	O
Blue-faced Booby			b	bR	r
<u>Visitors</u>					
Phoenix Petrel				R	
Newell's Shearwater				R	
Sooty Storm Petrel					R
Red-billed Tropicbird			R	r	
White-tailed Tropicbird	O		R	O	O
Lesser Frigatebird				R	
Blue-gray Noddy			r	R	
<u>Waterfowl, Marsh, and Land</u>					
<u>Birds:</u>					
<u>Regular Migrants</u>					
Pintail			R	R	R
American Golden Plover	R	R	R	R	R
Bristle-thighed Curlew	R		R	R	R
Wandering Tattler	R	R	R	R	R
Ruddy Turnstone	R	R	R	R	R
Sanderling			R	R	R
Pectoral Sandpiper				R	R
<u>Irregular Visitors</u>					
American Wigeon				R	?
Northern Shoveler				R	?
Glaucous-winged Gull				R	?
Herring Gull			R		R
Laughing Gull			R	R	
Short-eared Owl	R	?	R	R	
<u>Stragglers</u>					
Cattle Egret				R	R
Franklin's Gull					R

Source: Amerson and Shelton, 1976.

TABLE 18. (Continued)

	Akau	Hikina	Johnston	Sand	
				Original	Man-made
<u>Accidentals</u>					
Peregrine Falcon			R	R	
Black-bellied Plover			R	R	R
Semipalmated Plover				R	R
Lesser Yellowlegs				R	
Spotted Sandpiper				R	R
Willet			R		
Dowitcher species				R	
Western Sandpiper					R
Sharp-tailed Sandpiper			R	R	R
Buff-breasted Sandpiper					R
Ruff				R	R
Wilson's Phalarope				R	
Gull species			R		
Elegant Tern				R	
Skylark			R		R
Japanese White-eye			R		R
<u>Introductions</u>					
Domestic Chicken			B**		
Rock Dove			B**		
Society Finch					R
Present Breeders	1*	2**	6	11	3
Former Breeders	0	0	10	2	6
Total species	8	6	35	44	35

B = Breeder; R = Recorded; O = Overflier. Capital letters indicate status 1963-1969; lower case letters indicate status 1923-1962, if different than at present.

* bred only in 1964
 ** bred only in 1973.

TABLE 19. DISTRIBUTION AND STATUS* OF MAMMALS AT JOHNSTON ATOLL

Species	Akau	Hikina	Johnston	Sand	
				Original	Man-made
House Mouse			B	B	B
Roof Rat			B		
Domestic Dog			R	R	R
Domestic Cat		R	B	R	R
Hawaiian Monk Seal	R	R	R	B	R
European Rabbit			R		R

*B = Breeding; R = Recorded.

Source: Amerson and Shelton, 1976.

TABLE 20. DISTRIBUTION* OF BENTHIC MARINE ALGAE AT JOHNSTON ATOLL

Species	Division	Marginal Reef	Lagoon		
			Open Water	Inshore Johnston	Inshore Sand
Cyanophyta					
<i>Anacystis dimidiata</i>			1		1
<i>Entophysalis deusta</i>				3	
<i>Schizothrix calcicola</i>		3	6	5	2
<i>Hydrocoleum lyngbyaceum</i>		1		1	1
<i>Microcoleus chthonoplastes</i>			4		1
<i>Microcoleus tenerrimus</i>		1		1	
<i>Microcoleus vaginatus</i>		1			
<i>Lyngbia aestuarii</i>		1		1	1
<i>Lyngbia confervoides</i>					1
<i>Lyngbia lutea</i>			1		
<i>Lyngbia majuscula</i>		1	3	1	2
<i>Spirulina tenerrima</i>			1	1	
<i>Synploca atlantica</i>		1		1	
<i>Oscillatoria nigroviridis</i>				1	
<i>Phormidium submembranaceum</i>		3	3	1	
<i>Homothamion enteromorphaoides</i>			2	1	
<i>Calothrix crustacea</i>			1		1
<i>Calothrix scopulorum</i>		3	3	4	1
<i>Isactis plana</i>		2		5	1
Chlorophyta					
<i>Palmellopsis protuberans</i>				1	
<i>Enteromorpha kyllini</i>				1	
<i>Cladophora cristallina</i>		2	2	1	
<i>Cladophoropsis</i> sp.		1			
<i>Valoniopsis ventricosa</i>			1		
<i>Dictyosphaeria cereclujoid</i>		6	6	4	1
<i>Brodiaea composita</i>		1			
<i>Microdictyon californicum</i>		5	2		1
<i>Derbesia marina</i>				1	
<i>Derbesia</i> sp.			1		
<i>Caulerpa ambigua</i>		1	1	2	1
<i>Caulerpa racemosa macrophylla</i>			1		
<i>Caulerpa verticillata</i>		3	1		1
<i>Bryopsis plumosa</i>		5	4	4	1
<i>Pseudochlorodesmia parva</i>		2		3	
<i>Codium arabicum</i>		1			
<i>Codium</i> sp.		3	2	4	
<i>Halimeda discoides</i>		3	2	1	
<i>Halimeda</i> sp.		3			
<i>Acartularia clavata</i>				2	
<i>Acartularia tubifera</i>		3	2	2	
<i>Acartularia thompsoniana</i>				1	
<i>Acartularia</i> sp.		1			1

TABLE 20. (Continued)

Species	Division	Marginal Reef	Lagoon		
			Open Water	Inshore Johnston	Inshore Sand
Chrysophyta					
<i>Ostreobium reineckeii</i>				2	
Phaeophyta					
<i>Ectocarpus breviararticulatus</i>				3	
<i>Ectocarpus indicus</i>		3	3	4	1
<i>Ectocarpus irregularis</i>				1	
<i>Ectocarpus</i> sp.			1		
<i>Sphacelaria furcigera</i>			1	1	
<i>Sphacelaria novaehollandiae</i>		5	7	5	2
<i>Sphacelaria tribuloides</i>				1	
<i>Dictyota</i> sp.		2	1	1	
<i>Pocockiella variegata</i>		6	5	3	
Rhodophyta					
<i>Asterocystis ornata</i>			1		
<i>Goniotrichum alsidii</i>			1		
<i>Erythrotrichia</i> sp.			1		
<i>Gelidium crinale perpusillum</i>			3	3	1
<i>Gelidium pusillum pusillum</i>			4	3	2
<i>Wurdemania</i> sp.		3	1	2	
<i>Jania capillacea</i>		3	6	2	2
<i>Jania decussato-dichotoma</i>		4	2	2	1
<i>Amphiroa</i> sp.		1	1		
<i>Hypnea esperi</i>		4	4	4	1
<i>Lomentaria hakodatensis</i>		1	1	1	1
<i>Champia parvula</i>		2			
<i>Antithamnion antillarum</i>		2	1	1	1
<i>Callithamnion marshallensis</i>		2		2	
<i>Callithamnion</i> sp.		1			
<i>Centroceras apiculatum</i>		5	5	4	2
<i>Centroceras clavulatum</i>		1	3	1	1
<i>Crouania minutissima</i>		1			
<i>Ceramium affine</i>		3	5	1	1
<i>Ceramium fimbriatum</i>		1			
<i>Ceramium gracillimum byssoideum</i>		4	4	4	1
<i>Ceramium huysmansii</i>		3	3	1	
<i>Ceramium maryae</i>		1			
<i>Ceramium vagabunde</i>		2	2		
<i>Ceramium zavae</i>		1		2	1
<i>Ceramium</i> sp.			2		
<i>Crouania minutissima</i>		1			
<i>Griffithsia metcalfei</i>			2		
<i>Griffithsia ovalis</i>		1			

TABLE 20. (Continued)

Species	Division	Marginal Reef	Lagoon		
			Open Water	Inshore Johnston	Inshore Sand
Rhodophyta (cont.)					
<i>Griffithsia tenuis</i>		4	1	2	
<i>Griffithsia</i> sp.					1
<i>Dasya adherens</i>		1	1		
<i>Dasya sinicola</i>		3	1		
<i>Dasya</i> sp.		1	2		
<i>Taenioma macrourum</i>		1	3		
<i>Caloglossa leprieurii</i>			1		
<i>Heterosiphonia wurdemanii laxa</i>		2	2		
<i>Herposiphonia</i> spp.		4	3	1	1
<i>Polysiphonia</i> spp.		3	7	5	1
<i>Laurencia</i> sp.		4	5	1	
<i>Chondria repens</i>		4	3		

*Figures indicate total number of collection stations from which samples were taken. Marginal Reef localities: 1,2,4,12,27,28,29; Lagoon Open Water: 3,5,6,8,9,10,11,17; Lagoon Inshore Johnston: 13,14,15,16,18,19,20,21,22,23,24; Lagoon Inshore Sand: 7,25,26,30.

TABLE 21. CNIDARIA (COELENTERATA) FROM JOHNSTON ATOLL*

Class Family Species	Wells 1934	Brock <i>et al.</i> 1965	Present Paper
Hydrozoa			
Milleporidae			
<i>Millepora tenera</i>	X		
<i>Millepora</i> sp.			X
Stylasterinidae			
<i>Distichopora</i> sp.	X		
<i>Stylaster</i> sp.			X
Anthozoa			
Pocilloporidae			
<i>Pocillopora damicornis</i>		X	
<i>Pocillopora eydouxi</i>	X		
<i>Pocillopora meandrina</i>		X	
Acroporidae			
<i>Acropora humilis</i>	X		
<i>Acropora hyacinthus</i>	X		
<i>Acropora retusa</i>	X		
<i>Acropora tumida</i>	X		
<i>Montipora verrucosa</i>	X		
<i>Montipora</i> sp.	X		
Agariciidae			
<i>Leptastrea</i> sp.	X		
<i>Pavona varians</i>		X	
<i>Pavona</i> sp.	X		
Fungiidae			
<i>Fungia scutaria</i>	X		
Poritidae			
<i>Portites lutea</i>	X		
Isopheliidae			
<i>Telmatactis decora</i>		?	X

*Taxonomic order follows Bayer, *et al.* (1956).

TABLE 22. DISTRIBUTION AND ABUNDANCE* OF MOLLUSCA FROM JOHNSTON ATOLL.

Gastropoda:	Marginal N.W. Reef	Johnston Island	Sand Island	Lagoon fill Sand Island
Trochidae				
<i>Trochus intectus</i> Reeve				U
Turbinidae				
<i>Turbo articulatus</i> Reeve	M			
Neritidae				
<i>Nerita plicata</i> Linnaeus		M	M	
<i>Nerita pinnata</i> Linnaeus			M	
<i>Nerita albicilla</i> Linnaeus			U	
<i>Nerita picea</i> Recluz		V	V	
Littorinidae				
<i>Littorina pincta</i> Wood		V	V	
<i>Littorina ululata</i> Gray		U		
<i>Littorina coccinea</i> (Gmelin)		U	M	
Planaxidae				
<i>Planaxis zonatus</i> A. Adams			U	
Modiolidae				
<i>Modiolus tectum</i> (Lamarck)				U
Cerithiidae				
<i>Rhinoclavis sinensis</i> (Gmelin)			U	
<i>Rhinoclavis articulatus</i> Adams & Reeve			U	
<i>Cerithium mutatum</i> Sowerby				U
<i>Cerithium nesioticum</i> Pilsbry & Varatta				U
Hipponicidae				
<i>Sabia conica</i> (Schumacher)	U		U	
Strombidae				
<i>Strombus maculatus</i> Sowerby			U	U
Cypraeidae				
<i>Cypraea granulata</i> Pease				U
<i>Cypraea helvola</i> Linnaeus	U			M
<i>Cypraea poraria</i> Linnaeus	U			
<i>Cypraea caputserpentis</i> Linnaeus				U
<i>Cypraea moneta</i> Linnaeus	U			U
<i>Cypraea maculifer</i> (Schilder)				U

*V = Very abundant; M = Moderately abundant; U = uncommon.

Source: Amerson and Shelton. 1976.

TABLE 22. (Continued)

Gastropoda (cont.):	Marginal N.W. Reef	Johnston Island	Sand Island	Lagoon fill Sand Island
Cypraeidae (cont.)				
<i>Cypraea isabella</i> Linnaeus				M
<i>Cypraea carneola</i> Linnaeus				U
<i>Cypraea schilderorum</i> (Iredale)	U			M
Naticidae				
<i>Polinices (Mamilla) melano-</i> <i>stoma</i> (Gmelin)			U	
Cymatidae				
<i>Cymatium (Septa) nicobaricum</i> Röding				U
<i>Cymatium (Septa) aquatile</i> (Reeve)			U	U
<i>Cymatium (Septa) gemmatum</i> (Reeve)			U	
<i>Cymatium (Ranularia) muricinum</i> Röding			U	
<i>Distorsio anus</i> Linnaeus				U
Tonnidae				
<i>Tonna (Quimalea) pomum</i> (Linnaeus)				U
Muricidae				
<i>Maculotriron</i> species			U	
<i>Drupa morum</i> Röding	M			
<i>Drupa ricinus</i> (Linnaeus)	U		U	
<i>Morula uva</i> Röding	M		V	M
<i>Morula granulata</i> (Duclos)			M	
<i>Drupella ochrostoma</i> (Blainville)			U	
<i>Nassa sertum</i> Bruguière				M
Coralliophilidae				
<i>Coralliophila violacea</i> Kiener	M			
<i>Coralliophila malinponarum</i> (Sowerby)	M			
<i>Coralliophila</i> (Gmelin)	U			U
			U	
			M	
				U

TABLE 22. (Continued)

Gastropoda (cont.):	Marginal N.W. Reef	Johnston Island	Sand Island	Lagoon fill Sand Island
Turbinellidae				
<i>Vasum turbinellus</i> (Linnaeus)	U		U	U
Conidae				
<i>Conus pulicarius</i> Hwass	U			U
<i>Conus nanus</i> Sowerby	U			
<i>Conus rattus</i> Hwass	U			
<i>Conus vitulinus</i> Hwass	U			
<i>Conus miles</i> Linnaeus	U			
<i>Conus flavidus</i> Lamarck				U
Terebridae				
<i>Terebra crenulata</i> Linnaeus				U
Bivalvia:				
Isognomonidae				
<i>Isognomon perna</i> (Linnaeus)			M	
<i>Parviperna dentifera</i> (Krauss)			U	
Trapezidae				
<i>Trapezium oblongum</i> (Linnaeus)				U
Tellinidae				
<i>Arcopagia (Scutarcopagia)</i> <i>scobinata</i> (Linnaeus)				U

TABLE 23. ANNELIDA FROM JOHNSTON ATOLL*

Class	Edmondson	Brock	Present
Family	<i>et al.</i>	<i>et al.</i>	Paper
Species	1925	1965	
Polychaeta			
Amphinomidae			
<i>Eurythoe complanata</i> (Fallus)			X
<i>Eurythoe pacifica</i> Kinberg	X		
<i>Hermodice pinnata</i> Treadwell	X		
Cirratulidae			
<i>Cirratulus</i> sp.	X		X
Eunicidae			
<i>Eunice</i> sp.			X
Polynoidea			
<i>Hololepidella nigropunctata</i> (Horst)			X
Phyllodoceidae			
<i>Phyllodoce stigmata</i> Treadwell	X		X
Nereidae			
<i>Nereis kobeensis</i>		X	
<i>Perinereis helleri</i> (Grube)	X		X
Leodidae			
<i>Lysidice fusca</i> Treadwell	X		
<i>Lysidice</i> sp.		X	
Leodocidae			
<i>Leodice</i> sp.		X	

*Taxonomic order follows that in the Annelida collection of the National Museum of Natural History.

Source: Amerson and Shelton, 1976.

TABLE 24. MARINE ARTHROPODA FROM JOHNSTON ATOLL*

Class	Subclass	Family	Species	Edmondson <i>et al.</i> 1925	Brock <i>et al.</i> 1965, 1966	Present Paper
Crustacea						
	Cirripedia					
		Lepadidae				
			<i>Lepas anatifera</i> Linnaeus			X
	Malacostraca					
		Squillidae [=Chloridelidae?]				
			<i>Pseudosquilla oculata</i> (Brullé)	X		X
		Palaeomonidae				
			<i>Coralliocaris graninea</i> (Dana)	X		X
			<i>Harpiliopsis depressus</i> (Stimpson)	X	X	X
			<i>Jocaste lucina</i> (Nobili)	X		X
			<i>Palaeomonella tenuipes</i> Dana	X		
			<i>Peridomenaeus tridentatus</i> (Miers)	X		X
		Gnathophyllidae				
			<i>Gnathophyllum americanum</i> Guérin	X		X
		Alpheidae				
			<i>Alpheus brocipes</i> Stimpson		X	
			<i>Alpheus bucephalus</i> Coutière	X		X
			<i>Alpheus elypeatus</i> Coutière	X	X	X
			<i>Alpheus collusianus</i> Stimpson	X		X
			<i>Alpheus crassimanus</i> Heller	X		X
			<i>Alpheus diadema</i> Dana	X		X
			<i>Alpheus gracilis</i> Heller	X		X
			incl. subsp. <i>simplex</i> (Banaer)			
			<i>Alpheus leviusculus</i> Dana	X		X
			<i>Alpheus lottini</i> Guérin	X	X	
			<i>Alpheus paraerinitus</i> Miers	X		X
			<i>Alpheus paragracilis</i> Coutière	X		X
			<i>Synalpheus paraneomeris</i> Coutière	X		X
		Hippolytidae				
			<i>Lysmata paucidens</i> (Rathbun)	X		X
			<i>Saron marmoratus</i> (Olivier)	X		
		Panuridae				
			<i>Panulirus marginatus</i> (Quoy & Gaimard)			X
			<i>Panulirus pencillatus</i> (Olivier)	X		X
		Scyllaridae				
			<i>Parribacus antarcticus</i> (Lund)	X		X
		Axiidae				
			<i>Axiopsis johnstoni</i> Edmondson	X		X
		Galatheidae				
			<i>Galathea spinosirostris</i> Dana		X	

Source: Amerson and Shelton, 1976.

TABLE 24. (Continued)

Class	Subclass	Edmondson	Brock	
	Family	<i>et al.</i>	<i>et al.</i>	Present
	Species	1925	1965, 1966	Paper
Diogenidae				
	<i>Aniculus aniculus</i> (Fabricius)	X		?
	<i>Calcinus elegans</i> (N. Milne-Edwards)	X		X
	<i>Calcinus herbstii</i> de Man	X		X
	<i>Calcinus latens</i> (Randall)	X		X
	<i>Dardanus kaantii</i> Rathbun			X
	<i>Dardanus megistos</i> (Herbst)			X
	<i>Dardanus punctulatus</i>	X		
Dynomenidae				
	<i>Dynomene hispida</i> Desmarest	X		X
Calappidae				
	<i>Calappa hepatica</i> (Linnaeus)	X		
Leucosiidae				
	<i>Nucia speciosa</i> Dana	X		
Majidae				
	<i>Perinea tumida</i> Dana			X
	<i>Schizophrys hilensis</i> Rathbun		X	
Portunidae				
	<i>Cataptrus inaequalis</i> (Rathbun)	X		X
	<i>Portunus longispinosus</i> (Dana)	X		X
	<i>Thalamita admete</i> (Herbst)	X		X
	<i>Thalamitoides quidridens</i> A. Milne-Edwards	X		X
Xanthidae				
	<i>Carpilius convexus</i> (Forsk.)	X		X
	<i>Chlorodiella asper</i> Edmondson	X		X
	<i>Domocia hispida</i> Eydoux & Souleyet	X	X	X
	<i>Ectisus elceira</i> (Herbst)	X		X
	<i>Leptodius sanguineus</i> (H. Milne-Edwards)	X		X
	<i>Leptodius wialuanus</i> Rathbun	X		
	<i>Liocarpilodes biunguis</i> (Rathbun)	X		X
	<i>Liocarpilodes integerrimus</i> (Dana)			X
	<i>Liocre bella</i> (Dana)	X		X
	<i>Lophozozymus dodone</i> (Herbst)			X
	<i>Phymodius laysani</i> Rathbun	X		X
	<i>Phymodius nitidus</i> (Dana)	X		X
	<i>Pilodius aberrans</i> (Rathbun)	X		X
	<i>Pilodius areolata</i> (H. Milne-Edwards)			X
	<i>Platypodia eydouxii</i> (A. Milne-Edwards)	X		X
	<i>Pseudoliomera speciosa</i> (Dana)	X	?	X
	<i>Tetralia glaberrima</i> (Herbst)	X		
	<i>Tetralia</i> spp.		X	

TABLE 24. (Continued)

Class	Subclass	Edmondson	Brock	
	Family	<i>et al.</i>	<i>et al.</i>	Present
	Subspecies	1925	1965, 1966	Paper
Xanthidae (cont.)				
	<i>Trapezia cymodoce</i> (Herbst)		X	
	<i>Trapezia digitalis</i> Latreille	X	X	X
	<i>Trapezia ferruginea</i> Latreille	X		X
	<i>Trapezia intermedia</i> Miers	X		X
	<i>Trapezia maculata</i> (MacLeay)		X	X
	<i>Trapezia rufopunctata</i> (Herbst)	X		
	<i>Trapezia speciosa</i>	X		X
Ocypodidae				
	<i>Ocypode laevis</i> Dana			X
Grapsidae				
	<i>Grapsus strigosus</i> (Herbst)	X		X
	<i>Grapsus tenuicristatus</i> (Herbst)	X		X
	<i>Pachygrapsus minutus</i> A. Milne-Edwards	X		X
	<i>Pachygrapsus plicatus</i> (H. Milne-Edwards)			X
Hapalocarcinidae				
	<i>Hapalocarcinus marsupialis</i> Stimpson	X		X
	<i>Pseudoceryptochirus crescentus</i> (Edmondson)	X		X

*Taxonomic order follows Chase (pers. corres.).

TABLE 25. INSHORE FISHES RECORDED FROM JOHNSTON ATOLL

	Smith and Swain 1882 Fowler and Ball 1925 Halstead and Bunker 1954	Gosline 1955	Brock, <i>et al.</i> , 1965		Brock, <i>et al.</i> 1966
			Aug. 1963- 1963	Dec. 1963- June 1965	Aug. 1964- Aug. 1965
Myliobatidae (Eaglerays)					
<i>Aetobatus narinari</i>	X			X	X
Synodontidae (Lizardfishes)					
<i>Smurida gracillis</i>		X	X		
<i>Synodus binotatus</i>		X	X		
<i>Synodus variegatus</i>			X	X	
Congridae (Conger Eels)					
<i>Conger marginatus</i> (= <i>C. noorastekii</i>)		X			
Ophichthidae (Snake Eels)					
<i>Erechthysomorphis sauropsis</i>		X	X		
<i>Leururus semioinctus</i>	X	X	X		
<i>Leptenchelys labialis</i>		X			
<i>Muraenichelys cookei</i>		X	X		
<i>Muraenichthys gymnotus</i>		X			
<i>Muraenichthys schultzei</i>		X	X		
<i>Nyriichthys bleekeri</i>	X	X			
<i>Nyriichthys maculosus</i>	X	X	X		
<i>Fryllophichthys xenodontus</i>				X	
<i>Schultzidia johnstonensis</i>		X	X		
Xenocoagridae (False Moray Eels)					
<i>Kaupichthys diodontus</i>				X	
Moringuidae (Worm Eels)					
<i>Moringua macrochir</i>		X	X		

Source: Amerson and Shelton, 1976.

TABLE 25. (Continued)

	Smith and Swain 1882 Fowler and Ball 1925 Halstead and Bunker 1954	Gosline 1955	Brock, et al., 1965		Brock, et al.,
			Aug. 1963	Dec. 1963- June 1965	Aug. 1964- Aug. 1965
Muraenidae (Moray Eels)					
<i>Anarchias allardicei</i>		X	X		
<i>Anarchias cantonensis</i>		X			
<i>Anarchias leucurus</i>		X	X		
<i>Echidna leucotaenia</i>		X			
<i>Echidna polyzona</i>		X			
<i>Echidna unicolor</i>			X		
<i>Echidna zebra</i>		X			
<i>Gymnothorax</i> sp.			X		
<i>Gymnothorax buroensis</i>	X				
<i>Gymnothorax eurostus</i>		X	X	X	
<i>Gymnothorax gracilicaudus</i>		X	X		
<i>Gymnothorax javanicus</i>	X		X	X	
<i>Gymnothorax meloagris</i>	X		X		X
<i>Gymnothorax moluensis</i>		X	X		
<i>Gymnothorax piatus</i>	X				
<i>Gymnothorax undulatus</i>		X	X		
<i>Rabula fuscomaculata</i>		X	X	X	
<i>Uropterygius</i> sp.				X	
<i>Uropterygius fuscoguttatus</i>		X	X		
<i>Uropterygius knighti</i>			X		
<i>Uropterygius polyaspilus</i>		X			
<i>Uropterygius supraforatus</i>		X	X		
(= <i>U. dentatus</i>)					
<i>Uropterygius tigrinus</i>	X	X			
Belonidae (Needlefishes)					
<i>Belone platyura</i>	X	X			
Heniramphidae (Halfbeaks)					
<i>Hyporhamphus acutus</i>		X	X		

TABLE 25. (Continued)

	Smith and Swain 1882		Gosline 1955	Brock, et al., 1965		Brock, et al., 1966
	Fowler and Ball 1925	Halstead and Bunker 1954		Aug. 1963	Dec. 1963- June 1965	Aug. 1964- Aug. 1965
Exocoetidae (Flyingfishes)						
<i>Cypselurus peocilopterus</i>	X					
<i>Cypselurus simus</i>	X					
Aulostomidae (Trumpetfishes)						
<i>Aulostomus chinensis</i>	X		X	X	X	X
Fistulariidae (Cornetfishes)						
<i>Fistularia petimba</i>	X		X	X	X	
Syngnathidae (Pipefishes)						
<i>Doryrhamphus melanopleura</i>				X		
Holocentridae (Soldierfishes or Squirrelfishes)						
<i>Holocentrus lacteoguttatus</i>	X		X	X		
<i>Holocentrus microstomus</i>	X					
<i>Holocentrus sarriana</i>	X		X	X	X	X
<i>Holocentrus spinifer</i>	X		X	X	X	X
<i>Holocentrus tiere</i>	X		X	X	X	X
<i>Holotrachys lima</i>			X	X		
<i>Myripristis argyromus</i>	X		X	X	X	
<i>Myripristis berndti</i>	X			X		
Apogonidae (Cardinal Fishes)						
<i>Apogon erythrinus</i>			X	X		
<i>Apogon manesemus</i>			X	X	X	X
<i>Apogon snyderi</i>	X		X	X		
<i>Apogon waikiki</i>			X			
<i>Pseudamiops gracilicauda</i>			X	X		

TABLE 25. (Continued)

	Smith and Swain 1882	Fowler and Ball 1925	Hairstead and Bunker 1954	Gosline 1955	Brock, et al., 1965		Brock, et al., 1966
					Aug. 1963	Dec. 1963- June 1965	Aug. 1964- Aug. 1965
Kuhliidae (Aholeholes)							
<i>Kuhlia marginata</i>	X			X			
Grammistidae (=Pseudo- chromidae)							
<i>Pseudogramma polyacantha</i>				X	X	X	
Priacanthidae (Big Eyes)							
<i>Priacanthus cruentatus</i>	X			X	X		
Serranidae (Sea Bass)							
<i>Pristipomoides sieboldii</i>	X						
Lutjanidae (Snappers)							
<i>Aphareus furcatus</i>					X		
Kyphosidae (Rudderfishes)							
<i>Kyphosus bigibbus</i>				X			
<i>Kyphosus vaigiensis</i>				X			
Mullidae (Sunmulletts, Goat- fishes)							
<i>Mulloidichthys auriflamma</i>	X				X	X	X
<i>Mulloidichthys samoensis</i>	X			X	X	X	X
<i>Parupeneus barberinus</i>	X				X	X	X
<i>Parupeneus bifasciatus</i>	X			X	X	X	X
<i>Parupeneus chryserydros</i>	X				X	X	X
<i>Parupeneus crassilabris</i>	X				X	X	X
<i>Parupeneus multifasciatus</i>	X			X			
<i>Parupeneus trifasciatus</i>	X						

TABLE 25. (Continued)

	Smith and Swain 1882	Gosline 1955	Brock, et al., 1965		Brock, et al., 1966
	Fowler and Ball 1925 Halstead and Bunker 1954		Aug. 1963	Dec. 1963- June 1963	Aug. 1964- Aug. 1965
Cirrhitidae (Hawkfishes)					
<i>Amblycirrhites bimacula</i>		X	X		
<i>Cirrhitus alternatus</i>			X	X	
<i>Cirrhitus pinnulatus</i>	X	X	X		
<i>Paracirrhites arcatus</i>			X	X	
<i>Paracirrhites forsteri</i>			X	X	
Carangidae (Pompano, Ulua, Papio)					
<i>Carangoides ferdau</i>	X	X		X	
<i>Caranx ascensionis</i>	X				
<i>Caranx dason</i>	X				
<i>Caranx gymnotethoides</i>	X				
<i>Caranx lugubris</i>	X				
<i>Caranx melampygus</i>	X			X	X
<i>C. (=Gnathanodon) speciosus</i>					X
<i>Scomberoides sancti-petri</i>	X		X		
<i>Tracharops crumenophthalmus</i>		X			
Pomacentridae (Damsel-fishes)					
<i>Abudefduf imparipennis</i>	X	X		X	X
<i>Abudefduf phoenixensis</i>	X	X			
<i>Abudefduf sordidus</i>	X			X	X
<i>Chromis leucurus</i>	X	X	X	X	X
<i>Chromis vanderbilti</i>		X	X	X	X
<i>Dascyllus albisella</i>					
<i>Dascyllus marginatus</i>	X				X
<i>Plectroglyphidodon johns- tonianus</i>	X	X	X	X	X

TABLE 25. (Continued)

	Smith and Swain 1882	Fowler and Ball 1925	Halstead and Bunker 1954	Gosline 1955	Brock, et al., 1965		Brock, et al.,
					Aug. 1963	Dec. 1963- June 1963	1966 Aug. 1964- Aug. 1965
Labridae (Wrasses)							
<i>Bodianus bilunulatus</i>	X					X	X
<i>Cheilodius rhodochrous</i>	X					X	X
<i>Cheilio inermis</i>					X	X	
<i>Cheilio flavovittata</i>							X
<i>Coris gardneri</i>					X	X	X
<i>Epicolus insidiator</i>	X			X	X	X	X
<i>Gomphosus varius</i>	X			X	X	X	X
(includes <i>G. tricolor</i>)							
<i>Halichoeres ornatissimus</i>	X			X		X	
<i>Lobroides pithiophagus</i>					X	X	X
<i>Neoglyphidodon taeniourus</i>				X			
<i>Pseudocheilodius hexataenia</i>	X						
<i>Pseudocheilodius octotaenia</i>				X		X	
<i>Pseudocheilodius tetrataenia</i>					X	X	
<i>Stethojulis albivittata</i>						X	X
<i>Stethojulis axillaris</i>				X	X	X	X
<i>Thalassoma ballieui</i>	X				X	X	X
<i>Thalassoma fuscum</i>					X		
<i>Thalassoma duperreyi</i>	X			X	X	X	X
<i>Thalassoma lutescens</i>	X			X	X	X	X
<i>Thalassoma purpuraceum</i>	X						X
<i>Thalassoma quinquevittata</i>				X	X	X	X
<i>Thalassoma umbrostigma</i>							X
Scaridae (Parrotfishes)							
<i>Calotomus spinidens</i>				X	X		X
(= <i>C. sandvicensis</i>)							
<i>Scarus cyanogrammus</i>	X						
<i>Scarus dubius</i>	X			X	X		X
<i>Scarus duperreyi</i>	X						

TABLE 25. (Continued)

	Smith and Swain 1882	Fowler and Ball 1925	Halstead and Bunker 1954	Gosline 1955	Brock, et al., 1965		Brock, et al.,
					Aug. 1963	Dec. 1963- June 1963	1966 Aug. 1964- Aug. 1965
Scaridae (cont.)							
<i>Scarus erythrodon</i>	X						
<i>Scarus forsteri</i>	X						
<i>Scarus perspicillatus</i>	X			X	X	X	X
<i>Scarus sordidus</i>	X			X	X	X	X
<i>Scarus</i> sp. (grey)							X
<i>Scarus</i> sp. (blue-green)							X
Chaetodontidae (Butterfly- fishes)							
<i>Centropyge flammus</i>	X			X		X	X
<i>Centropyge nigriocellus</i>	X				X		
<i>Chaetodon auriga</i>	X			X	X	X	X
<i>Chaetodon citrinellus</i>	X			X	X	X	X
<i>Chaetodon ephippium</i>	X			X	X	X	X
<i>Chaetodon multivinctus</i>	X			X	X	X	X
<i>Chaetodon ornatissimus</i>	X			X	X	X	X
<i>Chaetodon quadrimaculatus</i>	X			X	X	X	X
<i>Chaetodon reticulatus</i>					X	X	
<i>Chaetodon trifasciatus</i>	X				X	X	X
<i>Chaetodon unimaculatus</i>	X			X	X	X	X
<i>Chaetodon eol</i>						X	
<i>Forcipiger longirostris</i>					X	X	
<i>Hermitaurichthys thompsoni</i>					X	X	X
<i>Megaprotodon strigangulus</i>	X				X	X	X
Zanclidae (Moorish Idols)							
<i>Zanclus cornutus</i>	X			X		X	X
Acanthuridae (Surgeonfishes)							
<i>Acanthurus achilles</i>	X			X	X	X	X
<i>Acanthurus glaucopareius</i>					X	X	X

TABLE 25. (Continued)

	Smith and Swain 1882	Fowler and Bali 1925	Gosline 1955	Brock, et al., 1965		Brock, et al., 1966
				Aug. 1963	Dec. 1963- June 1963	Aug. 1964- Aug. 1965
Acanthuridae (cont.)						
<i>Acanthurus guttatus</i>					X	
<i>Acanthurus nana</i>						X
<i>Acanthurus nigroris</i> (= <i>A. elongatus</i>)	X		X	X	X	X
<i>Acanthurus olivaceus</i>	X		X		X	X
<i>Acanthurus sandwicensis</i>	X		X	X	X	X
<i>Ctenopoma cyanoguttatum</i>						X
<i>Ctenopoma hawaiiense</i>					X	X
<i>Ctenopoma muriei</i>	X					
<i>Ctenopoma striatum</i>	X		X	X	X	X
<i>Naso lituratus</i>	X		X	X	X	X
<i>Naso undecimis</i>	X		X	X		
<i>Zelussona flavescens</i>	X		X	X	X	X
<i>Zelussona velifera</i>				X		
Eleotridae (Sleepers)						
<i>Eutota viridis</i>	X					
Gobiidae (Gobies)						
<i>Bathygobius fuscus</i>	X					
<i>Gnatholepis anferensis</i>			X	X	X	
<i>Hazeus unisquamis</i>				X		
<i>Zonogobius faxatmen</i>			X			
Blenniidae (Blennies)						
<i>Cirrhipetites variolosus</i>	X		X	X	X	
<i>Emallias brevis</i>			X	X		
<i>Istiblennius gibbifrons</i> (= <i>Salaria gibbifrons</i>)	X		X	X		

TABLE 25. (Continued)

	Smith and Swain 1882 Fowler and Ball 1925 Halstead and Bunker 1954	Gosline 1955	Brock, et al., 1965		Brock, et al., 1966
			Aug. 1963	Dec. 1963- June 1963	Aug. 1964- Aug. 1965
Brotulidae (Brotulids)					
<i>Brotula townsendi</i>		X			
Mugilidae (Mulletts)					
<i>Neomyxus chaptalii</i>	X	X			
Sphyraenidae (Barracudas)					
<i>Sphyraena japonica</i>	X				
Polynemidae (Threadfins)					
<i>Polydactylus sexfilis</i>	X				
Scorpaenidae (Scorpion Fishes)					
<i>Scorpaena balliexi</i>		X			
<i>Scorpaena contorta</i>		X			
<i>Scorpaenodes parvipinnis</i>			X		
Bothidae (Flounder or Flatfishes)					
<i>Bothus rancus</i>	X	X		X	X
Echeneidae (Remoras)					
<i>Remora remora</i>		X			
Balistidae (Triggerfishes)					
<i>Balistes bursa</i>			X		
<i>Melichthys buriwa</i>	X	X	X	X	X
<i>Melichthys ringens</i>	X				
<i>Melichthys vidua</i>	X	X		X	X
<i>Rhinecanthus aculeatus</i>	X	X	X	X	X

TABLE 25. (Continued)

	Smith and Swain 1882 Fowler and Ball 1925 Halstead and Bunker 1954	Gosline 1955	Brock, et al., 1965		Brock, et al., 1966
			Aug. 1963	Dec. 1963- June 1963	Aug. 1964- Aug. 1965
Monacanthidae (Filefishes)					
<i>Aluteria scripta</i>			X	X	
<i>Acanases carolae</i>	X				X
<i>Acanases sarawachiensis</i>	X	X	X	X	
<i>Pervagor melanocephalus</i>	X	X	X	X	
<i>Pervagor spilosoma</i>					X
Ostraciontidae (Trunkfishes)					
<i>Xentropocarpus hexagonus</i>	X				
<i>Ostracion cubicus</i>	X				
<i>Ostracion lentiginosus</i>	X	X	X	X	X
<i>Ostracion meleagris</i>	X				
<i>Ostracion solorensis</i>	X		X		X
Tetraodontidae (Puffers)					
<i>Arothron meleagris</i>	X	X	X	X	X
Canthigasteridae (Sharp-nosed Puffers)					
<i>Canthigaster jaetator</i>	X	X	X	X	X
Diodontidae (Box Fishes)					
<i>Diodon hystrix</i>	X				
Total Species	109	111	115	85	73
New to Atoll	109	49	29	1	5
Old Species Not Seen	0	46	71	101	120

Bulwer's Petrel



Wedge-tailed Shearwater



Christmas Shearwater



Red-tailed Tropicbird

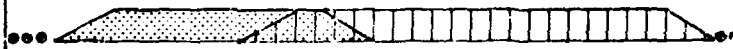

Brown Booby



Red-footed Booby



Great Frigatebird



Gray-backed Tern



Sooty Tern



Brown Noddy



Black Noddy

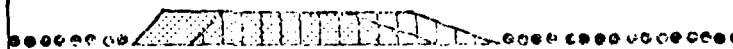

White Tern

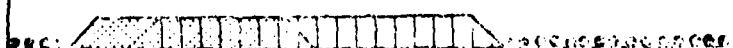

J F M A M J J A S O N D

FIGURE 2. BREEDING CYCLES OF SEABIRDS AT JOHNSTON ATOLL; STIPPLED AREA REPRESENTS EGGS, BARRED AREA YOUNG, AND BLACK DOTS NON-BREEDING BIRDS

Source: Amerson and Shelton, 1976.

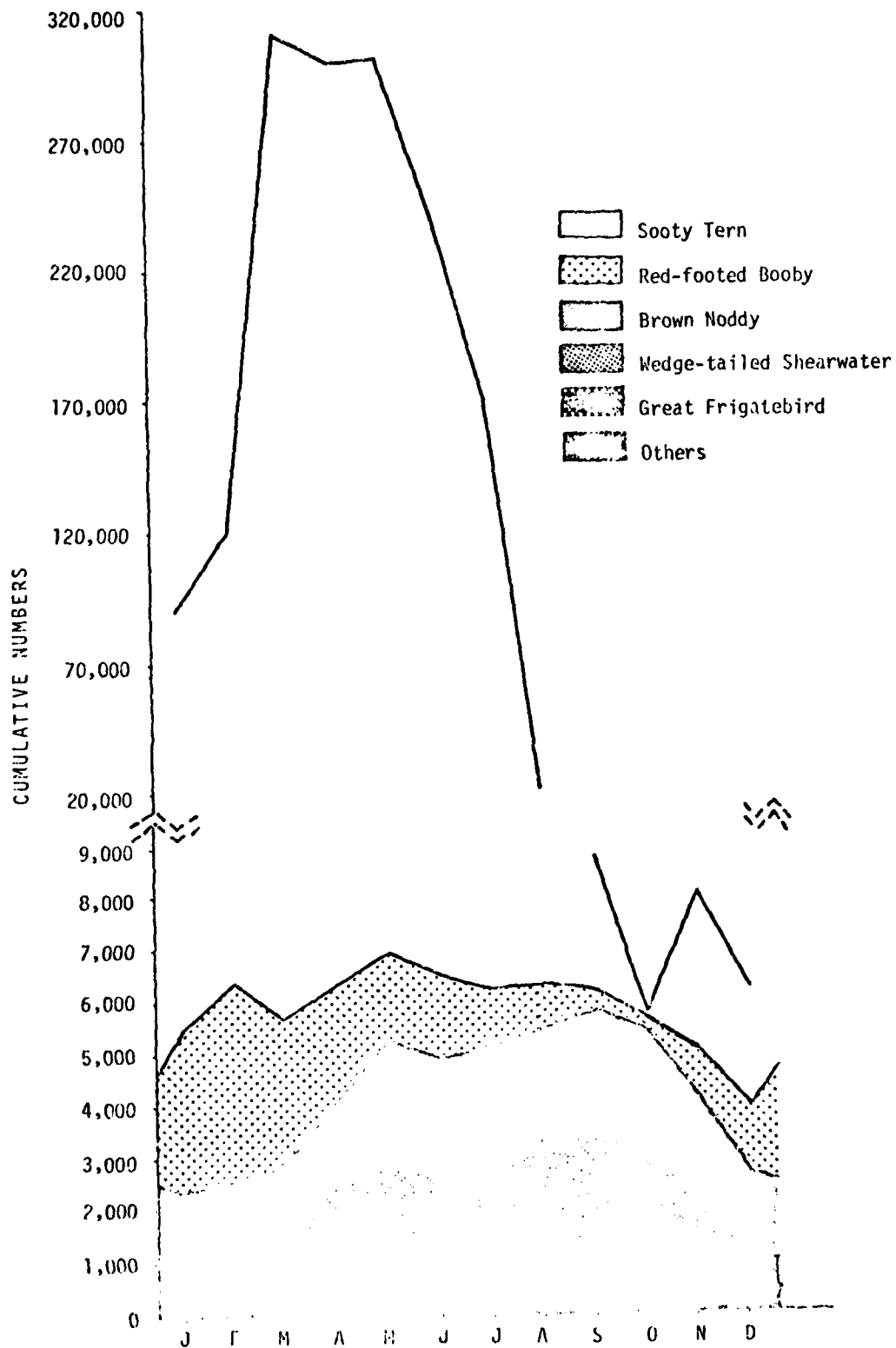

FIGURE 3. MONTHLY CUMMULATIVE BIRD POPULATIONS, JOHNSTON ATOLL 1963-1969
Source: Amerson and Shelton, 1976.

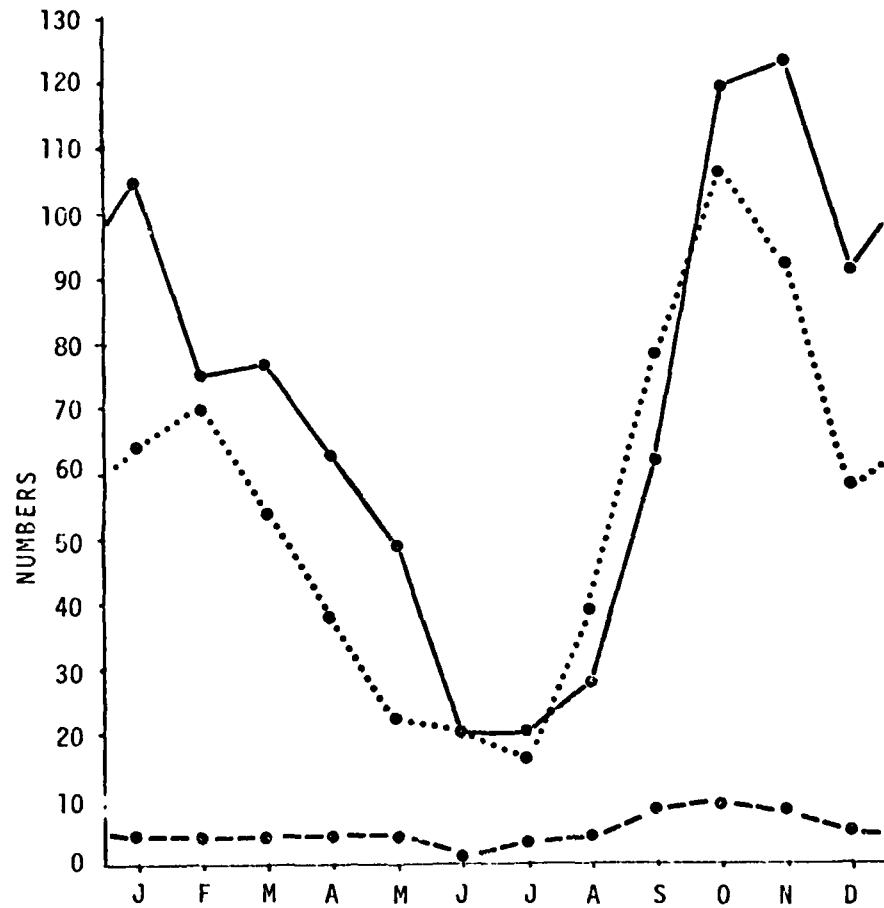

FIGURE 4. MONTHLY MEAN SHOREBIRD POPULATIONS FOR JOHNSTON ATOLL, 1963-1969; GOLDEN PLOVER (SOLID LINE), RUDDY TURNSTONE (DOTS), WANDERING TATTLER (DASHES)

Source: Amerson and Shelton, 1976.

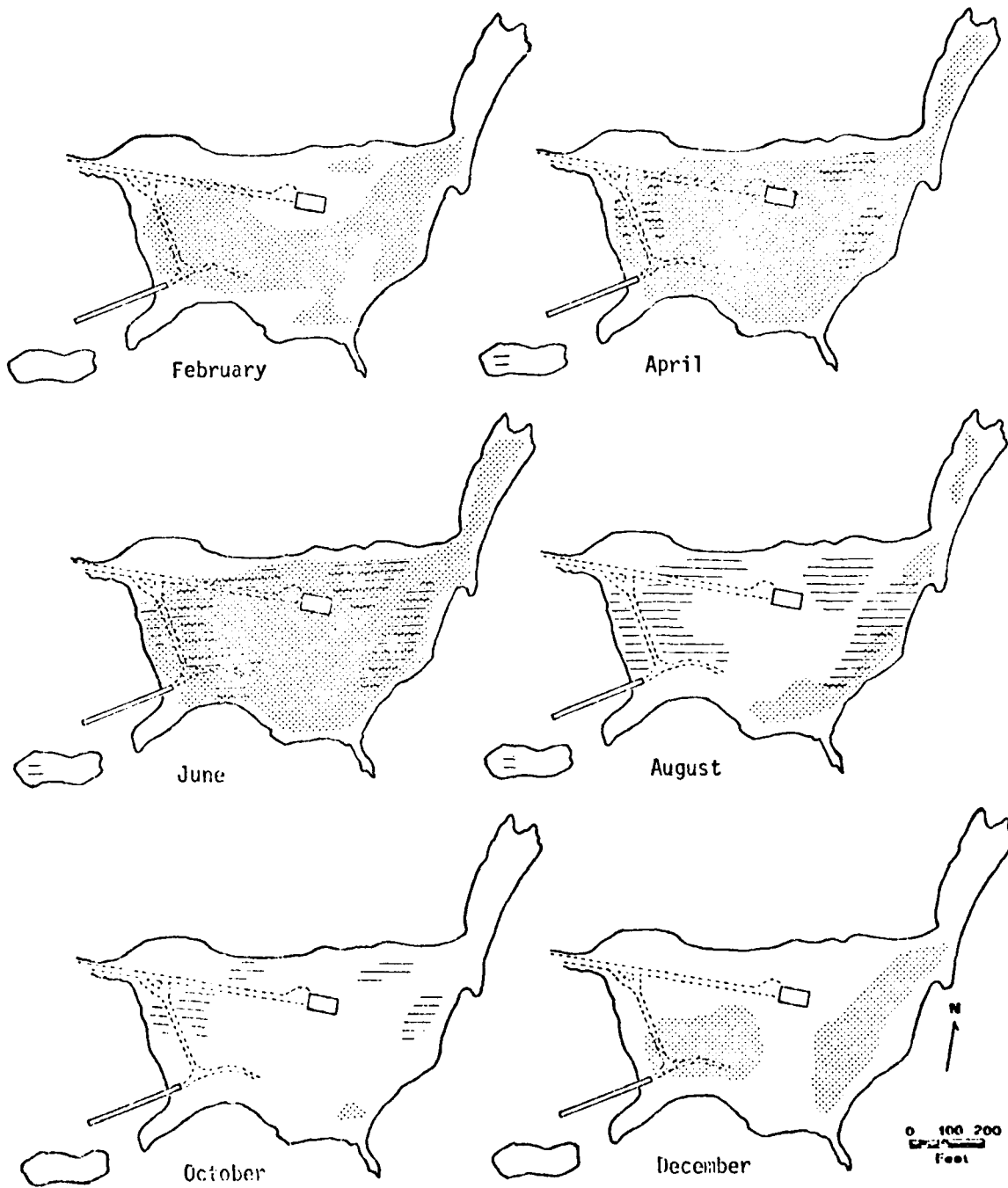

FIGURE 5. AREAS USED BY SOOTY TERNS (STIPPLED) AND WEDGE-TAILED SHEARWATERS (BARRED) ON SAND ISLAND, JOHNSTON ATOLL, 1965. Source: Amerson and Shelton, 1976.

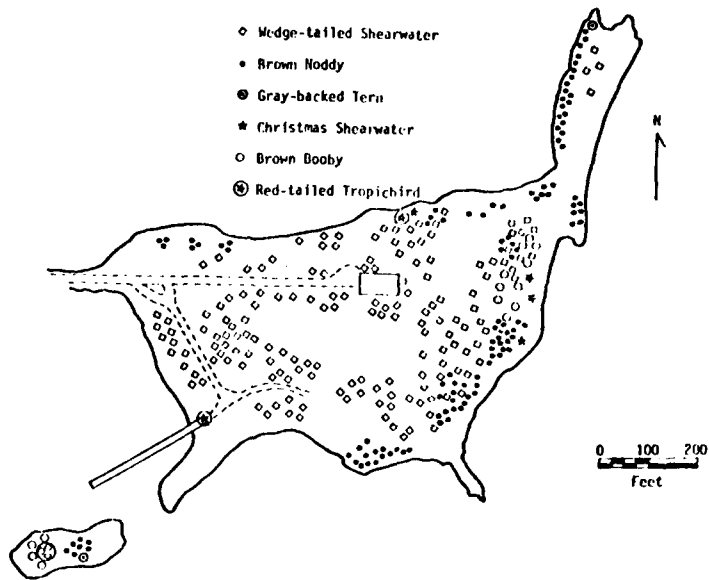

FIGURE 6. NESTING AREAS OF GROUND NESTING BIRDS (EXCEPT SOOTY TERNS) ON THE ORIGINAL PORTION OF SAND ISLAND, JOHNSTON ATOLL, 1963

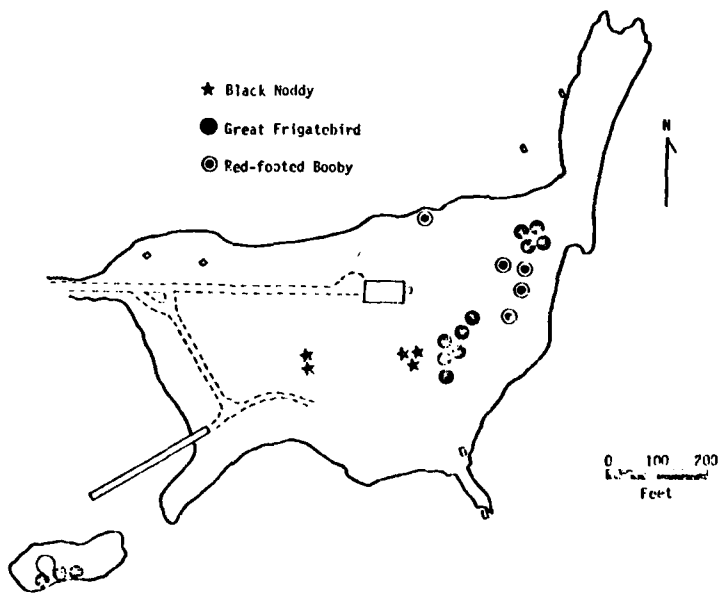

FIGURE 7. NESTING AREAS OF BIRDS WHICH NORMALLY NEST IN LOW VEGETATION ON THE ORIGINAL PORTION OF SAND ISLAND, JOHNSTON ATOLL, 1963
 Source: Amerson and Shelton, 1976.

TABLE 26. RECOVERY STUDIES FOR WATER SAMPLES

Compound	Spiked Concentration (ppb)		Found Concentration (ppb)	% Received
	Nominal	Actual		
2,4-D	10	10.6	3.64	34.3
2,4,5-T		10.0	2.75	27.5
2,4-D	10	10.6	4.21	39.7
2,4,5-T		10.0	4.88	48.5
2,4-D	10	10.6	3.11	29.3
2,4,5-T		10.0	2.67	26.7
2,4-D	10	10.6	4.03	38.0
2,4,5-T		10.0	4.70	47.0
2,4-D	5	5.3	3.15	62.6
2,4,5-T		5.0	3.70	74.0
2,4-D	5	5.3	2.48	46.8
2,4,5-T		5.0	2.47	49.4
2,4-D	5	5.3	3.58	67.5
2,4,5-T		5.0	3.67	73.4
2,4-D	5	5.3	2.46	46.4
2,4,5-T		5.0	2.98	59.6
2,4-D	5	5.3	1.28	24.2
2,4,5-T		5.0	1.52	30.4
2,4-D	1	1.06	0.460	43.3
2,4,5-T		1.00	0.537	53.7
2,4-D	1	1.06	0.845	79.7
2,4,5-T		1.00	0.923	92.3
2,4-D	Average			47.37
2,4,5-T	Average			54.44

50.91% = Correction Factor = 1.96

TABLE 27. RECOVERY STUDIES ON WIPE SAMPLE
ANALYTICAL PROCEDURE

Compound	Spiked Amount ($\mu\text{g}/\text{spl}$)		Recovery (Percentage)	
	Nominal	Actual	Recovered Amount	Percent Recovered
2,4-D	1.0	1.4	2.04	146
2,4,5-T	1.0	1.1	1.78	162
2,4-D	1.0	1.4	1.89	135
2,4,5-T	1.0	1.1	1.52	138
2,4-D	10.0	15.0	15.91	105
2,4,5-T	10.0	12.7	14.73	106
2,4-D	10.0	15.0	15.82	105
2,4,5-T	10.0	12.7	13.41	106
2,4-D	50.0	75.0	79.13	106
2,4,5-T	50.0	63.5	70.97	112
2,4-D	50.0	75.0	80.12	107
2,4,5-T	50.0	63.5	71.54	113
2,4-D	100.0	150.0	142.66	95
2,4,5-T	100.0	127.0	130.80	103
2,4-D	100.0	150.0	154.92	103
2,4,5-T	100.0	127.0	143.40	113

TABLE 28. EQUIPMENT LISTING, PROJECT PACER HO JOHNSTON ISLAND EFFORT

	Quantity Supplied	Quantity Needed
FREEZER, Marvel, Small below bench, Model 972-570 Curtin Scientific 4110L016223 EHL Tag: 00317 Serial No: 00190	1 each	1 each
FURNACE, Muffle, Thermolyne type 10500, Curtin 177-218 6640L109101 EHL Tag: None Serial No: None	1 each	1 each
OVEN, National Model 430 Curtin 252-080 6640L016261 EHL Tag: 630 Serial No: None	1 each	1 each
OVEN, Power-O-Matic, Blue M Model POM-256C-1 Curtin 184-473 6640L016232 EHL Tag: 267 Serial No: CD-12513	1 each	1 each
OVEN, Labline Model 3500M, Curtin 184-754 6640L016230 EHL Tag: None Serial No: 1174	1 each	1 each
BALANCE, Top Loading, Mettler P2010 6620L016262 EHL Tag: 266 Serial No: 580334	1 each	1 each
BALANCE, Analytical, Mettler Model H54 6670L016237 EHL Tag: 273 Serial No: 607758	1 each	1 each
BATH, Water, Labline Model 3012 Precision Scientific 6640L016260 EHL Tag: 939 Serial No: 1174	1 each	1 each
BATH, Water, Freas Model 170, Cat #66569 6640L020101 EHL Tag: None Serial No: 11-2-6	1 each	1 each
DEMINEALIZER, Corning LD-2, Curtin 252-130, equipped with solenoid accessory kit (Curtin 252-155) and automatic still adapter (Curtin 252-148) 4610L016228 EHL Tag: 633 Serial No: None	1 each	1 each
ULTRASONIC CLEANER, Mettler Model ME-1.5, Cole Parmer 8845-50 6530L101403 EHL Tag: 261/265 Serial No: None	2 each	1 each
CART, Glassware, metal frame with additional (4) wire baskets	1 each	2 each
HOT PLATE, Corning Model PC-100, Curtin 137-2731 7310L016238 EHL Tag: None Serial No: None	2 each	1 each
TUBE HEATER, Kontes K72000 6640L324300 EHL Tag: 264 Serial No: None	2 each	none

TABLE 28. (Continued)

	Quantity Supplied	Quantity Needed
VORTEX SHAKER	2 each	2 each
CYLINDER, Gas, 100# (Full) 90% Argon/10% methane (For Gas Chromatograph)	20 each	4 each
Tube extraction, 50 mm, SOXHLET	23	24
Extraction condenser, for 30 mm tube, 6 x 3 Corning 3840	14	24
Extraction flask, 500 ml 24/40, KIMAX 25055	24	24
Evaporative concentrator, 2-chambers, 19/22, tube capy - 4 ml size 2-19, K569000	12	24
Thermometer, 10-250 C, size 250, K870500	2	4
Evaporative concentrator, 2-chambers, 14/20, tube capy - 1 ml size 2-14, K569000	12	48
Chromaflex sample tube, 2 ml, 10/18, stopper, K422560	144	144
Distillation column, Snyder, 1-ball, 150 mm long, 2-joints, 24/40, size 121, K503000	21	48
Ebullator, for evaporative concentrator K569000	48	none
Ebullator, for evaporative concentrator K569350	24	none
Tube, for evaporative concentrator, capy - 20 ml, K749000-0005	36	48
Extraction, flask, boiling, 3 ml, 24/40, KIMAX 25055	11	24
Extraction thimbles, 80 x 25 mm	425	500
Centrifuge tubes, glass, conical, 15 ml	105	24
Tubes, culture, Teflon liner	48	none
Gas filter, high temperature, with 6 recharge bottles	1	2
Gas manifold, circular, nine-place K655800	2	none

TABLE 28. (Continued)

	Quantity Supplied	Quantity Needed
Evaporative concentrator, Kuderna-Danish, 125 ml, lower tube - 5 ml, 24/40, K570000	17	24
Evaporative concentrator, complete, copy - 1000 ml, K570000	3	none
Funnels, separatory, pear shape, Teflon plug, 60 ml	24	12
Funnels, separatory, pear shape, Teflon plug, 125 ml	12	none
Funnels, separatory, pear shape, Teflon plug, 200 ml	24	12
Rod, flexframe, 1/2 x 48 in.	2	10
Rod, flexframe, 1/2 x 24 in.	4	10
Base, support, 5 x 8 in., for 1/2 x 20 in. rod	2	6
Base, support, 6 x 11 in., for 1/2 x 36 in. rod	4	6
Rod, flexframe, 1/2 x 36 in.	9	10
Ring, support, 2 in.	10	10
Ring, support, 3 in.	10	10
Ring, support, 5 in.	10	10
Clamp, holder, castalloy R	30	48
Clamp, vinylized, 3-prong	12	24
Connector, hose, male, ips, 2-1/2 in. long for tubing 1 1/4 x 1/2 in.	12	12
Tube, connecting, straight, fits 3/8 to 1/2 in., 68 mm long	12	12
Tube, connecting, T-shaped, 3/16 bore	12	12
Clamp, Day's pinchcock, 2-5/8 in. long	12	12
Clamp, 3-prong, asbestos sleeve, 10-7/8 in. long	8	24

TABLE 28. (Continued)

	Quantity Supplied	Quantity Needed
Rod, flexframe, 1/2 x 20 in.	4	10
Rod, flexframe, 1/2 x 33 in.	2	10
Silica gel, indicating, can	13	1
Glass wool, roll	1	none
Florisil, 60-100 mesh, pesticide quality, 1b bottle	12	2
Sodium chloride, ACS reagent, 1b bottle	2	2
Potassium Hydroxide, ACS reagent, 1b bottle	2	2
Chromerge, cleaning solution, (6 bottles/can) bottles	18	30
Packing material, GC column, 4% SE-30/6% OV-210, 80-100 mesh, Chromosorb W-HP, 25 g bottle	2	none
Packing material, GC column, 1.5% SP-2250/1.95% SP 2401, 80-100 mesh, Chromosorb W-HP, 25 g bottle	2	2
Chromosorb 102, 60-80 mesh, 50 g bottle	1	1
Glass wool, silanized, 50 g bottle	1	1
Col-treat, 1 ml vial	7	2
Syringe Kleen (CH 2030) 250 g bottle	1	1
Syringe Kleen SK-2, 250 g bottle	1	none
Leak check (similar to SNOOP), bottle	11	2
Syringe, guide, Kel-F for 701N syringe, ea.	3	none
Syringe, 10 microliter, 6 syringe pack	5	5
Ferrules, front, 1/4 in. O.D., Teflon, ea.	102	50
Ferrules, front, 1/4 in. O.D., VESPEL, ea.	20	50
Septa, ea.	100	50

TABLE 28. (Continued)

	Quantity Supplied	Quantity Needed
Cutter, tubing, metal	1	1
Caps, end for GC glass columns, 1/4 in. O.D., ea.	100	10
Tags, aluminum, for GC columns, ea.	100	12
Funnel, metal, attachable to glass column, 1/4 in., ea.	2	2
Tape, Teflon, roll	2	2
Flowmeter, soap, 10 cc, ea.	1	1
Disc, 20 mm, Teflon laminated, ea.	240	144
Inserts, glass, for TRACOR GC, ea.	12	none
Key, hexagonal, set, 9 in one, ea.	1	1
Wrench, open end, 9/16 - 5/8 for 1/4 in. Swagelok, ea.	1	2
Pencil, diamond point, ea.	2	1
Chart, paper, omniscribe, roll	48	none
Pen, recorder, dacron, red, ea.	11	none
Pen, recorder, dacron, green, ea.	7	none
Paper, for System IV Integrator, roll	27	none
Pen, recorder, dacron, black, ea.	4	none
Stopwatch, 60 sec., with holder, ea.	1	1
Regulator, gas, two-stage, CGA-580 (nitrogen), ea.	2	2
Manifold, 3-stage, for CGA-580 connections, ea.	1	2
Gas purifier, 5-3/4 in. x 2 in., ea.	3	none
Cartridge for gas purifier, Model 451, ea.	30	none

TABLE 28. (Continued)

	Quantity Supplied	Quantity Needed
Activated desiccant for dehydrator purifier, ea.	24	12
Support, cylinder, bench/strap type, ea.	6	6
System IV Integrator - supplied (fuses, ribbon, lights) pkg.	1	none
Regulator, Gas, 2-stage, 8H350 (Argon/Methane)	2	2
Regulator, Gas, 2-stage, 8H590 (Air)	1	2
Pipets, Serological, 0.2 ml, ea.	18	none
Pipets, Serological, 0.5 ml, ea.	18	none
Pipets, Serological, 1.0 ml, ea.	18	none
Pipets, Serological, 5.0 ml, ea.	18	none
Pipets, Serological, 10.0 ml, ea.	18	none
Pipets, Volumetric, 0.5 ml, ea.	18	18
Pipets, Volumetric, 1.0 ml, ea.	18	18
Pipets, Volumetric, 2.0 ml, ea.	18	18
Pipets, Volumetric, 3.0 ml, ea.	18	18
Pipets, Volumetric, 5.0 ml, ea.	18	18
Pipets, Volumetric, 10.0 ml, ea.	18	18
Pipets, Bacteriological, disposable, 9 in., box (360)	4	24
Repipet dispenser, 10 ml (LI3010/all) ea.	1	2
Repipet dispenser, 50 ml (LI3010/all) ea.	1	2
Delivery head, Beckman No. 5062 (small), ea.	4	3
Delivery head, Beckman No. 5063 (large), ea.	1	1
Reservoir flasks, Earlenmeyer, 500 ml, ea.	3	4

TABLE 28. (Continued)

	Quantity Supplied	Quantity Needed
Reservoir top attachment, 5 ml, ea.	2	2
Reservoir top attachment, 50 ml, ea.	1	2
Reservoir top attachment, 10 ml, ea.	1	1
Thermometer, -20 to 110 C, ea.	2	1
Thermometer, -10 to 260 C, ea.	2	1
Thermometer, -10 to 400 C, ea.	2	1
Bulb, rubber, 1 ml, ea.	120	120
Bulb, rubber, 2 ml, ea.	12	none
Filler, pipete, rubber, ea.	8	8
Flask, Volumetric, 5 ml, ea.	23	10
Flask, Volumetric, 10 ml, ea.	24	10
Flask, Volumetric, 50 ml, ea.	21	10
Beaker, 50 ml, ea.	48	24
Flask, Earlenmeyer, 1000 ml, ea.	3	4
Cylinder, Graduated, 50 ml, ea.	18	5
Cylinder, Graduated, 100 ml, ea.	11	5
Cylinder, Graduated, 50 ml, ea.	12	5
Funnel, long stem, 65 x 100 mm lng, ea.	6	12
Funnel, filling, 80 mm dia. x 16 mm stem, ea.	11	12
Desiccator, T-sleeve top, 160 mm ID, 225 mm high, ea.	3	2
Flask, Volumetric, 25 ml, ea.	6	10

TABLE 28. (Continued)

	Quantity Supplied	Quantity Needed
Flask, Volumetric, 500 ml, ea.	4	2
Beaker, 1000 ml, ea.	48	24
Flask, Earlenmeyer, 25 ml, ea.	48	10
Flask, Earlenmeyer, 25 ml, with T stopper, ea.	6	6
Flask, filtering, 250 ml, ea.	4	none
Flask, filtering, 500 ml, ea.	4	4
Flask, Earlenmeyer, 50 ml, ea.	48	10
Flask, Earlenmeyer, 250 ml, ea.	108	10
Flask, Volumetric, 100 ml, ea.	24	24
Flask, Volumetric, 1000 ml, ea.	4	10
Beaker, 150 ml, ea.	48	10
Flask, Filtering, 1000 ml, ea.	1	1
Funnel, short stem, 65 mm, filtering, ea.	24	24
Beaker, 250 ml, ea.	48	10
Cylinder, Graduated, 1000 ml, ea.	4	8
Funnel, short stem, 150 mm dia., ea.	12	12
Beaker, 600 ml, ea.	36	10
Beaker, 2000 ml, ea.	8	10
Flask, Earlenmeyer, 1000 ml, ea.	18	10
Cartridge, demineralizer, organic, nipple ends, ea.	2	4
Cartridge, water demineralizer for LD2A, ea.	2	4

TABLE 28. (Continued)

	Quantity Supplied	Quantity Needed
Apron, neoprene, ea.	4	5
Bucket, plastic, 11 qt, ea.	2	4
Tray, plastic, 22 x 17 x 5-1/4 in., ea.	2	2
Chem-Solv, Glassware cleaner, pt. bottle	24	24
Goggles, safety, ea.	5	5
Gloves, latex, orange, 11 in. long, pair	12	12
Gloves, rubber, size 10, 11 in. long, pair	5	5
Gloves, vinyl, disposable, 4 x 25, ea.	50	50
Brush, cylinder, hardwood handle, 13 in., ea.	9	5
Brush, flask, flexible, plastic, 4-1/2 in. handle, 16 in. long, ea.	12	5
Brush, burette, 36 in. long, ea.	12	5
Brush, test tube, 8 in. long, ea.	11	5
Tubing, copper, 1/8 in. O.D., 50 ft roll	3	2
Tubing, copper, 1/4 in. O.D., 50 ft roll	1	2
Tubing, plastic, 1/4 ID x 1/2 O.D., 50 ft roll	1	4
Tubing, plastic, 1/2 in. ID x 3/4 O.D., 50 ft roll	1	4
Tubing, plastic, 1/2 in. ID x 3/4 O.D., 50 ft roll	1	1
Tubing, Rubber, white, 1/8 in. ID x 1/4 in. O.D., 50 ft roll	1	2
Tubing, Rubber, black, 1/4 in. ID x 3/4 in. O.D., 50 ft roll	10	none
Wire, soft aluminum, roll	2	1
Tubing, latex, 1/4 in. ID x 3/4 in. O.D., 50 ft roll	1	1

TABLE 28. (Continued)

	Quantity Supplied	Quantity Needed
Faucet, Laboratory	3	3
Scoop, lab, with handle, 7 in. long, ea.	12	12
Spatula, micro, ea.	9	9
Forceps, dissecting, tine curved, 115 mm., corrugated w/guide, ea.	2	2
Forceps, fine, straight, corrugated, 115 mm, w/guide, ea.	2	2
Forceps, laboratory, blunt, serrated, 5 in. long, ea.	2	2
Forceps, dressing, 5-1/2 in. long, ea.	2	none
Forceps, dressing, 10 in. long, ea.	1	none
Forceps, dressing, 4 in. long, ea.	2	none
Scissors, general, 5-1/2 in., ea.	2	2
Tongs, lab, crucible, 9 in., ea.	12	6
Tongs, crucible, 9 in., oxidized, steel, ea.	4	none
Timers, interval, ea.	3	4
Paper, filter, Whatman No. 40, acid washed, 110 mm, box	2	2
pH paper, dispenser, double roll, (1-11 pH) ea.	4	4
Tape, label, vinyl, 3/4 in. x 500 in., roll	2	4
Foil, aluminum, 500 ft roll	2	4
Wire baskets, vinyl coated for glassware cart	5	10
Brush, 9 in. long, for conical test tubes	12	5
Gloves, vinyl utility	400	400

TABLE 28. (Continued)

	Quantity Supplied	Quantity Needed
Gloves, asbestos (pair)	2	4
BF ₃ , cylinders	3	3
Gloves, rubber, pair	2	4
Tray with Swagelok fittings	1	2

TABLE 29. BULK CHEMICALS LISTING, PROJECT PACER HO
JOHNSTON ISLAND EFFORT

	Chemical	Unit/Issue	Cases	Total Supplied	Total Needed
6810L227569	HEXANE, P.G.	GAL	9	<u>36</u>	40
6810L227119	ETHYL EHTER, P.G.	CN	4	<u>24</u>	32
6810L202759	BENZENE, P.G.	GAL	27	<u>108</u>	4
6810L227570	ACETONE, P.G.	GAL	9	<u>36</u>	24
6810L0326EL	ETHYLENE CLYCOL, P.G.	GAL	1	<u>4</u>	2
6810L0283EL	DICHLOROMETHANE, P.G.	GAL	4	<u>16</u>	4
6810L227565	ISO-OCTANE, P.G. (2,2,4 TRIMETHYL PENTANE)	GAL	2	<u>8</u>	10
6810L0281EL	METHYL ALCOHOL, P.G.	GAL	1	<u>4</u>	4
6810L227414	SULFURIC ACID, TECHNICAL	GAL	5	<u>20</u>	24
6810L227572	SODIUM SULFATE, ANHYDROUS	LB/BTL (Plus 15 each btls from loose issue, bldg 3215)	2	<u>21</u>	2
7930L227563	CHROMERGE CLEANING SOL	CN	3	<u>36</u>	48

PACER HO Analytical Laboratory Analytical DataLand-Based Monitoring

Chromosorb (Air) Samples. The following codes are used in reporting the data given below:

ND = not detected
 NA = not analyzed
 Trace = at or below the lower limit
 of quantitation
 * = interferences observed,
 data unreliable

TABLE 30. ANALYTICAL DATA FOR CHROMOSORB (AIR) SAMPLES

Sample Code	Lab Code	Results ($\mu\text{g}/\text{sample}$) for Butyl Esters	
		2,4-D	2,4,5-T
Detection Limits for following Samples		0.08	0.04
Limit of Quantitation for following samples		0.4	0.4
CM24Y709J	CL-1	ND	ND
CW24Y709J	CL-2	ND	ND
CD24Y709J	CL-3	Trace	Trace
CC25Y709J	CL-4	ND	ND
CD25Y709J	CL-5	Trace	Trace
CM25Y709J	CL-6	ND	ND
CW25Y709J	CL-7	Trace	ND
CD26Y709J	CL-8	Trace	Trace
CM26Y709J	CL-9	Trace	ND
CN26Y709J	CL-10	Trace	Trace

TABLE 30. (Continued)

Sample Code	Lab Code	Results ($\mu\text{g}/\text{sample}$) for Butyl Esters	
		2,4-D	2,4,5-T
CP26Y709J	CL-11	Trace	Trace
CS26Y709J	CL-12	Trace	Trace
CW26Y709J	CL-13	ND	ND
CS27Y719J	CL-14	3.712	2.007
CD27Y719J	CL-15	0.567	Trace
CW27Y719J	CL-16	Trace	ND
CN27Y719J	CL-17	1.389	0.656
CP27Y719J	CL-18	Trace	Trace
CM27Y719J	CL-19	Trace	ND
CN28Y710J	CL-20	2.310	1.043
CM28Y707J	CL-21	Trace	ND
CW28Y708J	CL-22	Trace	ND
CS28Y709J	CL-23	2.041	1.097
CD28Y709J	CL-24	0.781	0.401
CP28Y710J	CL-25	ND	ND
CS28Y719J	CL-26	4.009	2.253
CD28Y719J	CL-27	0.620	0.307
CM28Y719J	CL-28	Trace	ND
CN28Y719J	CL-29	1.745	0.813
CW28Y719J	CL-30	Trace	ND
CP28y719J	CL-31	0.657	ND
PX29Y707J	CL-32	2.070	1.133
PV29Y707J	CL-33	2.231	1.118
PP29Y707J	CL-34	1.237	0.560
CM29Y708J	CL-35	ND	ND
CD29Y707J	CL-36	Trace	Trace
CW29Y708J	CL-37	Trace	Trace
CD29Y722J	CL-38	Trace	Trace

TABLE 30. (Continued)

Sample Code	Lab Code	Results ($\mu\text{g}/\text{sample}$) for Butyl Esters	
		2,4-D	2,4,5-T
CD30Y708J	CL-39	0.887	0.360
CM31Y701J	CL-40	Trace	ND
CD30Y719J	CL-41	0.625	Trace
CW31Y701J	CL-42	Trace	ND
PP30Y719J	CL-43	0.687	Trace
PU30Y719J	CL-44	3.123	1.412
PT30Y719J	CL-45	0.257	Trace
CM31Y708J	CL-46	Trace	ND
CW31Y708J	CL-47	Trace	ND
CD31Y708J	CL-48	0.406	Trace
PU31Y707J	CL-49	0.955	0.474
PT31Y707J	CL-50	2.876	1.523
PP31Y707J	CL-51	1.530	0.659
CD31Y719J	CL-52	0.488	Trace
CD02T709J	CL-53	0.993	0.543
CM03T701J	CL-54	Trace	ND
CW03T701J	CL-55	Trace	ND
CD02T719J	CL-56	0.54	Trace
PU02T719J	CL-57	2.31	1.16
PT02T719J	CL-58	2.16	1.02
PP02T719J	CL-59	3.08	1.32
PT03T707J	CL-60	1.46	0.70
PU03T707J	CL-61	2.02	0.98
PP03T707J	CL-62	2.19	1.03
CW03T708J	CL-63	Trace	ND
CD03T707J	CL-64	0.76	Trace
CM03T708J	CL-65	Trace	ND
(Chromosorb Blank)	CL-66	ND	ND

TABLE 3C. (Continued)

Sample Code	Lab Code	Results ($\mu\text{g}/\text{sample}$) for Butyl Esters	
		2,4-D	2,4,5-T
PQ03T719J	CL-67	1.94	0.99
CD03T719J	CL-68	0.93	Trace
PZ03T719J	CL-69	2.47	1.30
CM04T701J	CL-70	Trace	ND
CW04T701J	CL-71	Trace	ND
PV04T707J	CL-72	1.62	0.76
CW04T708J	CL-73	Trace	ND
CM04T708J	CL-74	Trace	ND
PX04T707J	CL-75	2.01	0.88
CD04T707J	CL-76	1.09	0.48
CM05T701J	CL-77	Trace	ND
CD04T719J	CL-78	0.74	Trace
CW05T701J	CL-79	Trace	ND
PR04T719J	CL-80	30.8	1.61
PZ04T719J	CL-81	2.60	1.36
CW05T708J#	CL-82	Trace	Trace
CD05T707J#	CL-83	ND	ND
CM05T708J#	CL-84	1.21	0.72
PU05T707J	CL-85	1.90	0.95
PT05T707J	CL-86	2.17	0.89
CD06T708J	CL-87	0.92	Trace
CM06T708J	CL-88	ND	ND
CM08T708J	CL-89	ND	ND
CW08T708J	CL-90	0.60	0.26

#Sucked in water

TABLE 30. (Continued)

Sample Code	Lab Code	Results ($\mu\text{g}/\text{sample}$) for Butyl Esters	
		2,4-D	2,4,5-T
Detection Limits for following samples		0.08	0.03
Limit of Quantitation for following samples		0.2	0.1
CW11T708J	CL-91	ND	ND
CM11T708J	CL-92	ND	ND
Blank	CL-93	ND	ND
CD17T713J	CL-94	1.29	0.69
CM17T713J	CL-95	ND	ND
PU17T713J	CL-96	2.83	1.67
PT17T713J	CL-97	2.56	1.53
CD17T719J	CL-98	1.01	0.39
CM17T720J	CL-99	ND	ND
PT17T719J	CL-100	3.68	2.03
PX17T719J	CL-101	1.57	0.92
CD18T707J	CL-102	3.92	1.65
CM18T707J	CL-103	ND	ND
PV18T707J	CL-104	2.30	1.43
PX18T707J	CL-105	3.07	1.90
CD18T719J	CL-106	0.98	0.34
CM18T720J	CL-107	ND	ND
PX18T719J	CL-108	1.42	0.73
PV18T719J	CL-109	1.80	0.97
CM20T708J	CL-110	Trace	ND
PU20T707J	CL-111	1.95	1.20
PX20T707J	CL-112	2.03	1.25
CD20T707J	CL-113	1.66	0.72
CW20T707J	CL-114	Trace	ND
PU20T719J	CL-115	3.61	2.14

TABLE 30. (Continued)

Sample Code	Lab Code	Results ($\mu\text{g}/\text{sample}$) for Butyl Esters	
		2,4-D	2,4,5-T
CW20T720J	CL-116	Trace	Trace
CD20T719J	CL-117	0.76	0.27
PR20T719J	CL-118	2.13	1.17
CM20T720J	CL-119	0.40	0.18
Blank	CL-120	ND	ND
CW21T708J	CL-121	Trace	ND
CM21T707J	CL-122	ND	ND
CD21T707J	CL-123	2.29	0.88
PU21T707J	CL-124	1.74	0.99
PX21T707J	CL-125	1.81	1.01
CD21T719J	CL-126	0.81	0.31
CW21T720J	CL-127	ND	ND
CM21T720J	CL-128	ND	ND
PT21T719J	CL-129	0.88	0.48
PY21T719J	CL-130	1.39	0.71
CD22T707J	CL-131	1.88	0.70
PX22T707J	CL-132	4.35	2.29
PU22T707J	CL-133	2.24	1.37
CM22T707J	CL-134	Trace	ND
CW22T707J	CL-135	Trace	ND
PR22T719J	CL-136	3.12	1.92
PX22T719J	CL-137	1.39	0.63
CW22T720J	CL-138	Trace	Trace
CM22T720J	CL-139	Trace	Trace
CD22T719J	CL-140	1.42	0.55
CS23T707J	CL-141	0.92	0.36
CD23T707J	CL-142	2.19	1.06
CM23T707J	CL-143	Trace	ND
CN23T707J	CL-144	0.32	Trace

TABLE 30. (Continued)

Sample Code	Lab Code	Results ($\mu\text{g}/\text{sample}$) for Butyl Esters	
		2,4-D	2,4,5-T
CW23T707J	CL-145	Trace	ND
CS23T717J	CL-146	1.26	0.45
CN23T717J	CL-147	1.24	0.52
CM23T717J	CL-148	Trace	Trace
CD23T717J	CL-149	1.43	0.74
CW23T717J	CL-150	Trace	ND
CW24T707J	CL-151	Trace	ND
CS24T707J	CL-152	0.75	0.20
CD24T707J	CL-153	0.72	0.24
CN24T707J	CL-154	1.28	0.50
CM24T707J	CL-155	Trace	ND
CW24T716J	CL-156	Trace	Trace
CN24T716J	CL-157	1.11	0.49
CM24T716J	CL-158	Trace	ND
CS24T716J	CL-159	1.51	0.50
CD24T716J	CL-160	1.83	0.81
CW25T707J	CL-161	ND	ND
CN25T707J	CL-162	1.08	0.42
CD25T707J	CL-163	1.29	0.64
CM25T707J	CL-164	ND	ND
CS25T707J	CL-165	1.21	0.43
CS25T716J	CL-166	21.3*	0.48
CN25T716J	CL-167	1.97*	0.54
CD25T716J	CL-168	2.54*	0.99
CW25T716J	CL-169	0.67*	ND
CM25T716J	CL-170	0.44*	ND
CD26T707J	CL-171	3.45*	0.52
CM26T707J	CL-172	1.67*	ND
CN26T707J	CL-173	0.66*	0.22
CS26T707J	CL-174	1.19*	0.21

TABLE 30. (Continued)

Sample Code	Lab Code	Results ($\mu\text{g}/\text{sample}$) for Butyl Esters	
		2,4-D	2,4,5-T
CW26T709J	CL-175	0.53*	ND
CW26T716J	CL-176	0.51*	ND
CM26T716J	CL-177	0.62*	ND

Water Samples. The following codes are used in reporting the data given below:

ND = not detected
 NA = not analyzed
 Trace = at or below the lower limit
 of quantitation

TABLE 31. ANALYTICAL DATA FOR WATER SAMPLES

Sample Code	Lab Code	Results (ppb) Methyl Esters	
		2,4-D	2,4,5-T
Detection Limits for following samples		0.1	0.1
Limit of Quantitation for following samples		0.25	0.25
WD24Y715J	WL-1G	ND	Trace
WS24Y700J	WL-2C	ND	ND
WF24Y700J	WL-3C	ND	ND
WO24Y700J	WL-4C	ND	ND
P125Y700J	WL-5C	Trace	Trace
P225Y714J	WL-5G	NA	NA
WS25Y700J	WL-6C	ND	ND
WO25Y700J	WL-7C	ND	ND
WF25Y700J	WL-8C	ND	ND
SE225Y710J	WL-9G	NA	NA
P126T700J	WL-10C	ND	Trace
P226Y715J	WL-10G	ND	ND
SE126Y700J	WL-11C	ND	ND
WS26Y700J	WL-12C	ND	ND
WF26Y700J	WL-13C	ND	ND
WO27Y700J	WL-14C	ND	ND
WF27Y700J	WL-15C	ND	ND
SE227Y711J	WL-16G	NA	NA
WS27Y700J	WL-17C	ND	ND

TABLE 31. (Continued)

Sample Code	Lab Code	Results (ppb) Methyl Esters	
		2,4-D	2,4,5-T
P227T715J	WL-18G	NA	NA
P127Y700J	WL-18C	ND	ND
SE228Y711J	WL-19G	NA	NA
SE128Y700J	WL-19C	8.93	13.09
P128Y700J	WL-20C	ND	ND
P228Y715J	WL-20G	NA	NA
WF28Y700J	WL-21C	ND	ND
WS28Y700J	WL-22C	ND	Trace
P129Y700J	WL-23C	ND	Trace
P229Y715J	WL-23G	NA	NA
WF29Y700J	WL-25C	ND	ND
WS29Y700J	WL-26C	ND	ND
WO29Y700J	WL-27C	ND	ND
SE229Y712J	WL-28G	22.81	27.23
WF30Y711J	WL-29G	47.57	54.14
WF30Y700J	WL-29C	0.45	0.41
P130Y700J	WL-30C	ND	Trace
P230Y715J	WL-30G	NA	NA
SE130Y700J	WL-31C	20.65	19.01
SE230Y712J	WL-31G	NA	NA
WS30Y700J	WL-32C	0.53	0.37
WS31Y700J	WL-33C	0.29	0.30
WF31Y700J	WL-34C	Trace	Trace
P231Y715J	WL-35G	NA	NA
P131Y700J	WL-35C	ND	Trace
WS01T700J	WL-36C	Trace	0.23
WF01T700J	WL-37C	Trace	0.24
WO01T700J	WL-38C	ND	ND

TABLE 31. (Continued)

Sample Code	Lab Code	Results (ppb) Methyl Esters	
		2,4-D	2,4,5-T
P101T700J	WL-39C	ND	Trace
P201T715J	WL-39G	ND	ND
P102T700J	WL-40C	ND	ND
SE102T700J	WL-41C	12.39	11.77
RW01T700J	WL-42	ND	Trace
W003T700J	WL-43C	ND	Trace
WS03T700J	WL-44C	Trace	Trace
WF03T700J	WL-45C	ND	Trace
P103T700J	WL-46C	ND	Trace
WS04T700J	WL-47C	Trace	Trace
WF04T700J	WL-48C	Trace	Trace
SE104T700J	WL-49C	46.60	47.16
P104T700J	WL-50C	ND	Trace
WS05T700J	WL-51C	Trace	Trace
W005T700J	WL-52C	ND	ND
WF05T700J	WL-53C	Trace	Trace
P105T700J	WL-54C	ND	ND
WD05T700J	WL-55C	ND	ND
WS06T700J	WL-56C	Trace	ND
WF06T700J	WL-57C	0.38	0.36
SE106T700J	WL-58C	65.63	72.15
P106T700J	WL-59C	ND	ND
Detection Limits for following samples		0.1	0.1
Limit of Quantitation for following samples		0.2	0.2
WF09T700J	WL-60C	Trace	0.28
WS09T700J	WL-61C	ND	Trace

TABLE 31. (Continued)

Sample Code	Lab Code	Results (ppb) Methyl Esters	
		2,4-D	2,4,5-T
P109T700J	WL-62C	ND	Trace
SE109T700J	WL-63C	20.35	21.76
WF12T700J	WL-64C	ND	Trace
WS12T700J	WL-65C	ND	Trace
SE112T700J	WL-66C	12.26	13.59
P112T700J	WL-67C	ND	ND
Blank		ND	ND
WS16T700J	WL-68C	NA	NA
WF16T700J	WL-69C	NA	NA
SE16T700J	WL-70C	NA	NA
P116T700J	WL-71C	NA	NA
WR16T700J	WL-72C	ND	ND
WO17T700J	WL-73C	ND	Trace
WS17T700J	WL-74C	ND	Trace
WF17T700J	WL-75C	ND	Trace
P117T700J	WL-76C	ND	Trace
WF18T700J	WL-77C	ND	ND
WS18T700J	WL-78C	ND	ND
SE18T700J	WL-79C	53.17	55.89
P118T700J	WL-80C	ND	Trace
WO18T700J	WL-81C	ND	ND
WS19T700J	WL-82C	2.11	1.32
WF19T700J	WL-83C	0.33	0.25
P119T700J	WL-84C	ND	Trace
WFB19T710J	WL-85G	4698.1	3418.0
WF20T700J	WL-86C	1.02	0.88
WS20T700J	WL-87C	1.05	0.58
SE20T700J	WL-88C	28.95	16.32

TABLE 31. (Continued)

Sample Code	Lab Code	Results (ppb) Methyl Esters	
		2,4-D	2,4,5-T
P120T700J	WL-89C	ND	Trace
Blank		ND	ND
P121T700J	WL-90C	ND	Trace
WF21T700J	WL-91C	0.28	0.47
WS21T700J	WL-92C	ND	Trace
WF22T700J	WL-93C	ND	ND
WS22T700J	WL-94C	ND	Trace
W022T700J	WL-95C	ND	Trace
P122T700J	WL-96C	ND	Trace
WD22T708J	WL-97C	ND	Trace
WF23T700J	WL-98C	ND	Trace
WS23T700J	WL-99C	ND	ND
SE123T700J	WL-100C	29.60	29.16
P123T700J	WL-101C	ND	Trace
Blank		ND	ND
WF24T700J	WL-102C	ND	Trace
W024T700J	WL-103C	ND	ND
WS24T700J	WL-104C	ND	Trace
WD24T708J	WL-105C	ND	Trace
P124T700J	WL-106C	ND	ND
WS25T700J	WL-107C	ND	ND
WF25T700J	WL-108C	ND	ND
SE25T700J	WL-109C	3.88	2.83
P125T700J	WL-110C	ND	ND
Blank		ND	ND
WF26T700J	WL-111C	ND	ND
WS26T700J	WL-112C	ND	ND
P126T700J	WL-113C	ND	ND
SE26T700J	WL-114C	1.42	0.89

Drum Rinse Samples. The following codes are used in reporting the data given below:

D = day shift

N = night shift

The bottles were arbitrarily numbered, and were cleaned for re-use after analysis. The bottle analyses are presented in the order that the drum rinse samples were taken.

TABLE 32. ANALYTICAL DATA FOR DRUM RINSE SAMPLES

Bottle Code	Lab Code	Date	Total Weight	5 Drum Average ($\mu\text{g}/\text{ml}$)	Running Average ($\mu\text{g}/\text{ml}$)
			($\mu\text{g}/\text{ml}$) 2,4-D & 2,4,5-T		
		<u>July</u>			
R101	DR-1	28D	23.9		23.90
R120	DR-2	28D	3.7		13.80
R119	DR-3	28D	32.8		20.13
R118	DR-4	28D	7.9		17.08
R117	DR-5	28D	29.5	19.56	19.56
R116	DR-6	28D	23.4		20.20
R115	DR-7	28D	2.5		17.67
R114	DR-8	28D	70.6		24.29
R217	DR-9	28N	18.0		23.59
R213	DR-10	28N	17.50	26.40	22.98
R209	DR-11	28N	27.0		23.35
R201	DR-13	28N	4.3		20.52
R202	DR-14	28N	45.6		24.02
R214	DR-15	28N	16.2	19.74	21.90
R206	DR-16	28N	51.3		23.74
R203	DR-17	28N	21.5		23.61
R218	DR-18	28N	25.4		23.71
R210	DR-19	28N	3.6		22.65
R207	DR-20	28N	16.3	23.62	22.33
R219	DR-21	28N	37.3		23.04
R204	DR-22	28N	4.2		22.19
R320	DR-23	29D	2.0		21.31
R319	DR-24	29D	2.0		20.50

TABLE 32. (Continued)

Bottle Code	Lab Code	Date	Total Weight ($\mu\text{g/ml}$) 2,4-D & 2,4,5-T	5 Drum Average ($\mu\text{g/ml}$)	Running Average ($\mu\text{g/ml}$)
R315	DR-25	29D	2.0	9.50	19.76
R316	DR-26	29D	2.0		19.08
R312	DR-27	29D	10.6		18.77
R317	DR-28	30N	43.1		19.64
R313	DR-29	30N	21.0		19.68
R306	DR-30	30N	18.8	19.10	19.65
R302	DR-31	30N	14.8		19.50
R309	DR-32	30N	2.0		18.95
R314	DR-33	30N	7.8		18.61
R308	DR-34	30N	22.5		18.73
R311	DR-35	30N	27.9	15.00	18.99
R318	DR-36	30N	4.5		18.59
R30	DR-37	30N	11.9		18.41
R211	DR-38	31D	3.3		18.01
R106	DR-39	31D	4.1		17.65
R107	DR-40	31D	2.2	5.20	17.27
R220	DR-41	31D	4.2		16.95
R109	DR-42	31D	2.0		16.59
R113	DR-43	31D	4.2		16.30
R208	DR-44	31D	2.1		15.98
R111	DR-45	31D	5.3	3.56	15.74
R107	DR-46	31D	7.2		15.56
R-S-001	DR-47	31D	14.7		15.54
R-S-002	DR-48	31D	3.8		15.29
R-S-003	DR-49	31D	10.0		15.19
R-S-004	DR-50	31D	2.0	7.54	14.92
R-S-005	DR-51	31D	0		14.63

TABLE 32. (Continued)

Bottle Code	Lab Code	Date	Total Weight ($\mu\text{g/ml}$) 2,4-D & 2,4,5-T	5 Drum Average ($\mu\text{g/ml}$)	Running Average ($\mu\text{g/ml}$)
R112	DR-52	31D	11.6		14.57
R102	DR-53	31D	4.6		14.38
<u>August</u>					
R207	DR-54	2N	9.9		14.30
R214	DR-55	2N	15.9	8.40	14.33
R202	DR-56	2N	11.1		14.27
R217	DR-57	2N	29.1	14.53	
R205	DR-58	2N	16.5		14.57
R213	DR-59	2N	8.6		14.46
R120	DR-60	2N	8.9	14.84	14.37
R115	DR-61	2N	24.2		14.53
R201	DR-62	2N	8.4		14.43
R218	DR-63	2N	17.5		14.48
R210	DR-64	2N	6.9		14.36
R114	DR-65	2N	18.1	15.02	14.42
R204	DR-66	3D	3.4		14.25
R303	DR-67	3D	2.4		14.08
R320	DR-68	3D	2.0		13.90
R118	DR-69	3D	5.4		13.78
R113	DR-70	3D	3.6	3.36	13.63
R316	DR-71	3D	2.0		13.46
R319	DR-72	3D	24.7		13.62
R305	DR-73	3D	3.6		13.48
R310	DR-74	3D	2.2		13.33
R301	DR-75	3D	7.0	7.90	13.24
R206	DR-76	3D	2.5		13.10
R304	DR-77	3D	9.4		13.05
R203	DR-78	3N	15.1		13.08
R209	DR-79	3N	4.3		12.97

TABLE 32. (Continued)

Bottle Code	Lab Code	Date	Total Weight ($\mu\text{g}/\text{ml}$) 2,4-D & 2,4,5-T	5 Drum Average ($\mu\text{g}/\text{ml}$)	Running Average ($\mu\text{g}/\text{ml}$)
R306	DR-80	3N	2.0	6.66	12.83
R116	DR-81	3N	15.9		12.87
R311	DR-82	3N	5.9		12.79
R314	DR-83	3N	2.0		12.66
R313	DR-84	3N	3.2		12.54
R211	DR-85	3N	5.2	6.44	12.46
R312	DR-86	3N	9.3		12.42
R117	DR-87	3N	5.6		12.34
R307	DR-88	3N	7.1		12.28
R308	DR-89	3N	7.1		12.22
R302	DR-90	4D	6.1	7.04	12.16
R119	DR091	4D	2.0		12.04
R315	DR-92	4D	46.0		12.41
R212	DR-93	4D	9.9		12.39
R219	DR-94	4D	6.0		12.32
R111	DR-95	4D	15.7	15.92	12.35
R112	DR-96	4D	17.3		12.41
R102	DR-97	4D	11.8		12.40
R318	DR-98	4N	23.40		12.51
R317	DR-99	4N	9.5		12.48
R319	DR-100	4N	41.8	20.76	12.77
R107	DR-101	4N	14.1		12.79
R302	DR-102	4N	57.5		13.22
R309	DR-103	4N	11.9		13.21
R306	DR-104	5D	13.0		13.11
R314	DR-105	5D	80.6	35.42	13.85
R303	DR-106	5D	21.1		13.92

TABLE 32. (Continued)

Bottle Code	Lab Code	Date	Total Weight ($\mu\text{g}/\text{ml}$) 2,4-D & 2,4,5-T	5 Drum Average ($\mu\text{g}/\text{ml}$)	Running Average ($\mu\text{g}/\text{ml}$)
R113	DR-107	5D	54.4		14.30
R217	DR-108	5D	44.2		14.58
R201	DR-109	5D	11.1		14.54
R311	DR-110	5D	63.0	38.76	14.98
R207	DR-111	5D	15.0		14.98
R120	DR-112	5D	30.1		15.12
R213	DR-113	5D	56.0		15.48
R115	DR-114	5D	7.4		15.41
R208	DR-115	5D	21.8	26.06	15.47
R307	DR-116	5N	6.0		15.38
R214	DR-117	5N	54.8		15.72
R203	DR-118	5N	14.3		15.71
R116	DR-119	5N	9.9		15.66
R305	DR-120	5N	214.6	59.92	17.32
R103	DR-121	5N	19.2		17.33
R311#	RD-1	17D	70.7		17.76
R216	RD-2	17D	43.6		17.97
R209	RD-3	17D	34.5		18.11
R115	RD-4	17D	27.2		18.18
R204	RD-5	17D	11.5	37.50	18.13
R320	RD-6	17D	14.8		18.10
R217	RD-7	17N	15.6		18.08
R109	RD-8	17N	4.2		17.97
R118	RD-9	17N			17.98
R220	RD-10	17N	6.2	12.00	17.89
R114	RD-11	17N	4.7		17.79
R206	RD-12	17N	2.0		17.67
R208	RD-13	17N	7.6		17.59

#Beginning of 2nd de-drum period.

TABLE 32. (Continued)

Bottle Code	Lab Code	Date	Total Weight ($\mu\text{g/ml}$) 2,4-D & 2,4,5-T	5 Drum Average ($\mu\text{g/ml}$)	Running Average ($\mu\text{g/ml}$)
R214	RD-14	17N	7.1		17.52
R108	RD-15	17N	8.0	5.88	17.45
R113	RD-16	17N	4.9		17.35
R106	RD-17	17N	11.0		17.31
R119	RD-18	18D	9.2		17.25
R307	RD-19	18D	10.4		17.20
R315	RD-20	18D	8.6	8.82	17.14
R211	RD-21	18D	43.7		17.33
R107	RD-22	18D	139.4		18.19
R309	RD-23	18D	3.6		18.08
R111	RD-24	18D	16.1		18.07
R205	RD-25	18D	11.9	42.94	18.03
R101	RD-26	18D	31.7		18.12
R302	RD-27	18D	115.1		18.78
R219	RD-28	18N	13.5		18.74
R303	RD-29	18N	52.6		18.97
R212	RD-30	18N	14.4	45.46	18.94
R117	RD-31	18N	89.1		19.41
R308	RD-32	18N	5.2		19.31
R318	RD-33	18N	4.8		19.22
R102	RD-34	18N	12.2		19.17
R317	RD-35	18N	47.1	31.68	19.35
R313	RD-36	18N	38.8		19.48
R310	RD-37	18N	22.2		19.49
R115	RD-38	20D	114.2		20.09
R204	RD-39	20D	5.4		20.00
R109	RD-40	20D	79.4	52.00	20.37

TABLE 32. (Continued)

Bottle Code	Lab Code	Date	Total Weight ($\mu\text{g/ml}$) 2,4-D & 2,4,5-T	5 Drum Average ($\mu\text{g/ml}$)	Running Average ($\mu\text{g/ml}$)
R214	RD-41	20D	37.0		20.48
R206	RD-42	20N	19.9		20.47
R116	RD-43	20N	167.7		21.38
R113	RD-44	20N	34.3		21.45
R301	RD-45	20N	83.3	68.44	21.83
R305	RD-46	20N	7.2		21.74
R209	RD-47	20N	14.2		21.70
R220	RD-48	20N	28.3		21.74
R320	RD-49	20N	35.0		21.81
R208	RD-50	20N	38.5	24.64	21.91
R108	RD-51	20N	38.8		22.01
R114	RD-52	20N	30.3		22.06
R205	RD-53	20N	47.6		22.21
R111	RD-54	21D	23.8		22.22
R311	RD-55	21D	12.1	30.52	22.16
R203	RD-56	21D	16.2		22.12
R217	RD-57	21D	40.1		22.23
R315	RD-58	21D	38.5		22.32
R207	RD-59	21D	25.2		22.33
R106	RD-60	21D	10.1	26.02	22.27
R103	RD-61	21D	8.4		22.19
R314	RD-62	21D	26.3		22.21
R306	RD-63	21D	38.6		22.30
R202	RD-64	21D	6.4		22.21
R112	RD-65	21D	74.8	30.90	22.50
R303	RD-66	21D	4.8		22.40
R313	RD-67	21D	23.7		22.41
R102	RD-68	21N	2.2		22.30

TABLE 32. (Continued)

Bottle Code	Lab Code	Date	Total Weight ($\mu\text{g/ml}$) 2,4-D & 2,4,5-T	5 Drum Average ($\mu\text{g/ml}$)	Running Average ($\mu\text{g/ml}$)
R317	RD-69	21N	6.2		22.22
R309	RD-70	21N	14.3	10.24	22.18
R212	RD-71	21N	14.4		22.14
R307	RD-72	21N	27.2		22.16
R319	RD-73	21N	29.1		22.20
R119	RD-74	21N	4.3		22.11
R312	RD-75	21N	4.7	15.94	22.02
R310	RD-76	21N	13.7		21.97
R216	RD077	21N	2.0		21.87
R211	RD-78	21N	12.2		21.81
R201	RD-79	22D	2.7		21.71
R214	RD-80	22D	7.5	7.62	21.65
R316	RD-81	22D	8.1		21.58
R120	RD-82	22D	2.0		21.48
R215	RD-83	22D	15.0		21.45
R101	RD-84	22D	9.3		21.39
R117	RD-85	22D	9.6	8.80	21.33
R210	RD-86	22D	4.1		21.25
R307	RD-87	22N	2.4		21.16
R209	RD-88	22N	3.9		21.08
R216	RD-89	22N	4.4		21.00
R310	RD-90	22N	26.2	8.20	21.02
R212	RD-91	22N	2.9		20.93
R319	RD-92	22N	38.7		21.02
R102	RD-93	22N	12.8		20.98
R112	RD-94	22N	2.0		20.90
R303	RD-95	22N	19.1	15.30	20.82

TABLE 32. (Continued)

Bottle Code	Lab Code	Date	Total Weight ($\mu\text{g}/\text{ml}$) 2,4-D & 2,4,5-T	5 Drum Average ($\mu\text{g}/\text{ml}$)	Running Average ($\mu\text{g}/\text{ml}$)
R309	RD-96	22N	47.7		21.01
R312	RD-97	22N	9.0		20.96
R107	RD-98	22D	15.4		20.93
R116	RD-99	22D	2.7	18.70	20.85

Ship Samples

Wipe Samples. The following codes are used in reporting the data given below:

ND = not detected

NA = not analyzed

Trace = at or below the lower limit of quantitation

* = data reported in mg/swipe

TABLE 33. ANALYTICAL DATA FOR SHIP WIPE SAMPLES

Sample Code	Lab Code	Results ($\mu\text{g}/\text{swipe}$) Butyl Esters	
		2,4-D	2,4,5-T
Detection Limit for following samples		0.1	0.1
Limit of Quantitation for following samples		0.2	0.2
(DNA Owned) 31506	SW-1	42.6*	42.3*
(PACAF) 66L 1216	SW-2	25.1*	24.3*
(PACAF) 67L 440	SW-3	9.3*	9.3*
(PACAF) 67L 440	SW-4	10.3*	11.1*
(AFLC) 67 1280	SW-5	3.6*	3.6*
(AFLC) 67 1280	SW-6	13.3*	1.48*
SQ-01D-055-K	SW-7	23.0	31.2
SQ-02W-055-K	SW-8	15.5	21.3
SQ-03D-055-K	SW-9	12.5	17.4
SQ-04W-055-K	SW-10	21.2	28.1
SQ-05W-055-K	SW-11	10.6	14.6
SQ-06D-055-K	SW-12	48.9	63.9
SQ-08D-055-K	SW-13	2.4	2.4
SQ-09D-055-K	SW-14	18.1	24.3
SQ-10D-055-K	SW-15	31.5	37.2

TABLE 33. (Continued)

Sample Code	Lab Code	Results ($\mu\text{g}/\text{swipe}$) Butyl Esters	
		2,4-D	2,4,5-T
SQ-11D-055-K	SW-16	13.8	17.6
SCR-01-055-K	SW-17	28.6*	37.1*
SCR-02-055-K	SW-18	10.0	8.8
SPR-01-055-K	SW-19	1.8*	1.8*
SPR-02-055-K	SW-20	0.11*	0.15*
SITS-1C-065-K	SW-21	4.9*	4.9*
SITS-3C-065-K	SW-22	7.9*	8.2*
SITS-5C-065-K	SW-23	54.5*	57.1*
SQ-06D-055-K	SW-12 #2	37.6	50.9
SITS-1CW-08S-K	SW-24	41.3*	44.1*
SITS-2CW-08S-K	SW-25	19.1*	20.5*
SITS-3CW-08S-K	SW-26	54.9*	57.7*
SITS-4CW-08S-K	SW-27	28.5*	30.1*
SITS-5CW-08S-K	SW-28	24.1*	25.6*
SITS-3CF-09S-K	SW-29	89.0*	92.4*
SITS-1CC-08S-K	SW-30	6.1*	5.9*
SITS-2CC-08S-K	SW-31	24.0*	25.7*
SITS-3CC-08S-K	SW-32	66.9*	70.4*
SITS-4CC-08S-K	SW-33	58.3*	61.6*
SITS-5CC-08S-K	SW-34	140.5*	145.3*
SPR-01-09S-K	SW-35	0.84*	0.89*
SPR-02-09S-K	SW-36	137.3	165.2
SPR-05-09S-K	SW-37	19.1*	19.1*
SCR-01-09S-K	SW-38	14.0	16.3
SCR-02-09S-K	SW-39	2.4*	3.0*
SCR-05-09S-K	SW-40	9.3*	12.7*
SITS-3CW-11S-K	SW-41	22.6*	23.3*
SQ-01-K	SW-42	20.1	22.3

TABLE 33. (Continued)

Sample Code	Lab Code	Results ($\mu\text{g}/\text{swipe}$) Butyl Esters	
		2,4-D	2,4,5-T
SQ-04-K	SW-43	<1.0	<1.0
SQ-06-K	SW-44	23.3	25.7
SQ-10-K	SW-45	<1.0	<1.0
SQ-11-K	SW-46	<1.0	<1.0
SQ-13-K	SW-47	20.9	25.8
SQ-02-11S-K	SW-48	7.9	5.3
SQ-05-11S-K	SW-49	Trace	Trace
SQ-07-11S-K	SW-50	23.3	29.3
SQ-08-11S-K	SW-51	19.7	21.0
SQ-09-11S-K	SW-52	6.8	5.0
SQ-12-11S-K	SW-53	Trace	Trace

Impinger, Probe, and Line Rinse Samples. The following codes were used in reporting the data given below:

ND = not detected

NA = not analyzed

Trace = at or below the lower limit of quantitation

TABLE 34. ANALYTICAL DATA FOR SHIP'S IMPINGER, PROBE, AND LINE RINSE SAMPLES

Sample Code	Lab Code	Results ($\mu\text{g}/\text{sample}$) Butyl Esters	
		2,4-D	2,4,5-T
Detection limit for following samples		0.1 $\mu\text{g}/\text{ml}$	0.1 $\mu\text{g}/\text{ml}$
Limit of Quantitation for following samples		0.5 $\mu\text{g}/\text{ml}$	0.5 $\mu\text{g}/\text{ml}$
HO-1-BT-H-S-B-11:15	I-1	ND	ND
HO-1-BI-H-S-B-9:29	I-2	ND	ND
HO-1-BI-H-S-B-11:40	I-3	ND	ND
HO-1-BI-H-S-B-10:08	I-4	ND	ND
HO-1-BI-F-S-B-AF	I-5	ND	ND
Benzene and Acetone Blank	I-Blank	ND	ND
Acetone, Benzene Blank	I2-Blank	ND	ND
HO-2-BI-8/13-H-S-B-1210	I-6	ND	ND
HO-3-BI-8/24-A/B-S-B	I3-Blank	ND	ND
HO-3-BI-8/28-H-S-B	I-10	ND	ND
HO-1-PR-722-H-S-B	PR-1	ND	ND
HO-1-PR-725-H-S-B(2)	PR-2	ND	ND
HO-2-PR-8/13-H-S-B	PR-3	Trace	ND
HO-3-PR-9/01-H-S-B	PR-4	ND	ND
HO-1-LR-714-H-S-B (Fuel Bkg)	LR-1	ND	ND

TABLE 34. (Continued)

Sample Code	Lab Code	Results ($\mu\text{g}/\text{sample}$) Butyl Esters	
		2,4-D	2,4,5-t
HO-1-LR-715-H-S-B (Test 2)	LR-2	ND	ND
HO-1-LR-716-H-S-B	LR-3	ND	ND
HO-1-LR-718-S-B (Test 4)	LR-4	ND	ND
HO-1-LR-719-S-B (Test 5)	LR-5	ND	ND
HO-1-LR-719-S-B (Test 6)	LR-6		
HO-2-LR-8/13-H-S-B	LR-7	ND	ND
HO-3-LR-8/28-H-S-B	LR-8	ND	ND

Chromosorb (Air) Samples. The following codes are used in the reporting of the data given below:

NA = not analyzed

ND = not detected

Trace = at or below lower limit of quantitation

TABLE 35. ANALYTICAL DATA FOR SHIP'S CHROMOSORB (AIR) SAMPLES

Sample Code	Lab Code	Results ($\mu\text{g}/\text{sample}$) Butyl Esters	
		2,4-D	2,4,5-T
Detection Limits for the following samples		0.08	0.04
Limit of Quantitation for following samples		0.4	0.4
HO-1-PM-13-P-B-8	13C	0.3	0.07
HO-1-AM-14-F-I-B-8	14C	ND	0.02
HO-1-PM-15-H-P-B-20	15C	0.39	0.15
HO-1-PM-16-H-I-B-20	16C	ND	ND
HO-1-AM-17-H-P-B-8	17C	1.18	0.43
HO-1-AM-18-H-I-B-8	18C	0.2	Trace
HO-1-PM-19-H-P-B-20	19C	1.63	0.77
HO-1-PM-20-H-I-B-20	20C	0.91	0.43
HO-1-AM-21-H-P-B-8	21C	0.58	0.18
HO-1-AM-22-H-I-B-8	22C	1.8	0.88
HO-1-PM-23-H-P-B-20	23C	1.11	0.38
HO-1-PM-24-B-I-B-20	24C	0.10	0.06
Detection Limits for the following samples		0.08	0.03
Lower Limit of Quantitation for following samples		0.2	0.1
HO-1-PM-16-H-G-B-20	59C	Trace	ND

TABLE 35. (Continued)

Sample Code	Lab Code	Results ($\mu\text{g}/\text{sample}$) Butyl Esters	
		2,4-D	2,4,5-T
HO-1-PM-16-H-P-B-20	60C	0.38	0.09
HO-1-PM-16-H-C-B-20	61C	Trace	ND
HO-1-AM-18-H-G-B-8	68C	Trace	ND
HO-1-AM-18-H-P-B-8	69C	3.04	0.96
HO-1-AM-18-H-C-B-8	70C	0.06	Trace
HO-1-PM-18-H-C-B-20	71C	0.11	Trace
HO-1-PM-18-H-P-B-20	72C	Lost Sample	
HO-1-PM-18-H-G-B-20	73C	Trace	ND
HO-1-AM-16-H-C-B-8	90C	Trace	Trace
HO-1-AM-16-H-G-B-8	91C	0.09	Trace
HO-1-AM-16-H-P-B-8	92C	21.93	3.79
HO-1-AM-15-H-C-B-8	93C	Trace	Trace
HO-1-AM-15-H-G-B-8	94C	ND	ND
HO-1-AM-20-H-C-B-9	95C	Trace	Trace
HO-1-PM-20-H-G-B-20	96C	Trace	ND
HO-1-AM-22-H-G-B-8	97C	ND	ND
HO-1-PM-22-H-C-B-20	98C	Trace	ND
HO-2-AM-11-H-I-B-19	99C	24.63	13.79
HO-2-AM-12-H-P-B-19	100C	10.90	3.33
HO-2-AM-13-H-I-B-19	101C	49.55	27.69
HO-2-AM-14-H-P-B-19	102C	0.51	0.16
HO-2-AM-15-H-I-B-19	103C	1.23	0.60
HO-2-AM-6-H-P-B-19	104C	15.07	7.38
HO-2-AM-7-H-I-B-19	105C	28.52	15.63
HO-2-AM-8-H-P-B-19	106C	12.85	3.85
HO-2-AM-9-H-I-B-19	107C	2.23	1.16
HO-2-AM-10-H-P-B-10	108C	5.23	1.62
HO-2-AM-7-H-G-B-19	109C	0.40	0.11

TABLE 35. (Continued)

Sample Code	Lab Code	Results ($\mu\text{g}/\text{sample}$) Butyl Esters	
		2,4-D	2,4,5-T
HO-2-AM-8-H-C-B-19	110C	Trace	Trace
HO-2-AM-9-H-G-B-19	111C	1.00	0.35
HO-2-AM-10-H-C-B-19	112C	Trace	Trace
HO-2-AM-11-H-G-B-19	113C	0.52	0.15
HO-2-AM-12-H-C-B-19	114C	Trace	Trace
HO-3-AM-25-H-I-B-07	115C	34.51	16.50
HO-3-AM-25-H-G-B-07	116C	0.42	Trace
HO-3-AM-26-H-G-B-07	117C	0.38	Trace
HO-3-AM-27-H-I-B-07	118C	55.0	25.5
HO-3-AM-27-H-G-B-07	119C	0.49	0.11
HO-3-AM-29-H-I-B-07	120C	7.20	4.40
HO-3-AM-29-H-G-B-07	121C	1.10	0.31
HO-3-AM-30-H-G-B-07	122C	0.84	0.25
HO-3-AM-31-H-G-B-07	123C	1.10	0.30
HO-3-AM-31-H-I-B-07	124C	82.8	43.2
HO-3-AM-01-H-G-B-08	125C	0.89	0.23
HO-3-AM-02-H-G-B-08	126C	55.5	29.5
Tank 5C	127C	14.50	4.10
Tank 2C	128C	4.40	0.90
Tank 3C	129C	5.20	1.10
Tank 4C	130C	25.8	3.8
Tank 1C	131C	11.1	2.9
Tank 4S	132C	5.70	1.50

Tank Rinse Samples.

TABLE 36 . ANALYTICAL DATA FOR SHIP'S TANK RINSE SAMPLES

Sample Code	Lab Code	Results (mg/ml) Butyl Esters	
		2,4-D	2,4,5-T
RDF-03-07S-K-1930	DFR-1	83.3	84.9
RDF-04-08S-K-0200	DFR-2	88.4	90.3

Water Samples. The following codes are used in reporting the data given below:

ND = not detected

NA = not analyzed

Trace = at or below lower limit
of quantitation

TABLE 37. ANALYTICAL DATA FOR SHIP'S WATER SAMPLES

Sample Code	Lab Code	Results (ppb)	
		2,4-D (Me)	2,4,5-T (Me)
Detection Limit for following samples		0.1	0.1
Lower Limit of Quantitation for following samples		0.2	0.2
Ship's Drinking Water (Kitchen, Lower Wing Tank, STB)	VDW-1	ND	ND
HO-2-SW-8/16-H-T-1600	VDW-3	ND	ND
Ship's Drinking Water (8/28/77 @ 1350)	VDW-4	ND	ND

Dunnage Burn Air and Ash Samples.

TABLE 38. ANALYTICAL DATA FOR DUNNAGE BURN SAMPLES

Sample Code	Lab Code	Results ($\mu\text{g}/\text{sample}$) Butyl Esters	
		2,4-D	2,4,5-T
Detection Limits for the following samples		0.1	0.1
Limit of Quantitation for the following samples		0.5	0.5
SVW09S77 Background	HV-1	2.49*	2.41*
SDW09S77 Station No. 1	HV-2	1.52*	1.98*
SDW09S77 Station No. 2	HV-3	24.45	48.89
Incinerator Ash	Ash-1	3.44	1.64

*Normal background for untreated filter paper.